

Flexible Digital Modulation Analysis Guide

PSA Series Spectrum Analyzers

Option 241

This manual provides documentation for the following instruments:

Spectrum Analyzers:

E4440A (3 Hz – 26.50 GHz)

E4443A (3 Hz – 6.70 GHz)

E4445A (3 Hz – 13.20 GHz)

E4446A (3 Hz – 44.00 GHz)

E4447A (3 Hz – 42.98 GHz)

E4448A (3 Hz – 50.00 GHz)



Agilent Technologies

Manufacturing Part Number: E4440-90620

Supersedes E4440-90351

Printed in USA

June 2008

© Copyright 1999 - 2008 Agilent Technologies, Inc.

Notice

Agilent Technologies makes no warranty of any kind with regard to this material, including but not limited to, the implied warranties of merchantability and fitness for a particular purpose. Agilent Technologies shall not be liable for errors contained herein or for incidental or consequential damages in connection with the furnishing, performance, or use of this material.

The information contained in this document is subject to change without notice.

Additional Information

For the latest information about this analyzer, including firmware upgrades, application information, and product information, see the following URL:

<http://www.agilent.com/find/psa/>

1. Introduction

What Does the Agilent PSA Option 241 Do?	16
Installing Optional Measurement Personalities	18
Do You Have Enough Memory to Load All Your Personality Options?	18
How to Predict Your Memory Requirements	20
Loading an Optional Measurement Personality	22
Obtaining and Installing a License Key	22
Viewing a License Key	23
Using the Delete License Key on PSA	23
Ordering Optional Measurement Personalities	24

2. Making Measurements

Introduction	26
Setting Up the Test Equipment and DUT	28
Making the Initial Signal Connection	28
Configuring a MS Measurement System	28
Configuring a BTS Measurement System	29
Using Instrument Presets	30
Determining the RF Parameters of Your Signal	31
Using the Spectrum Measurement to View the RF Parameters of the Signal Under Test	31
Spectrum (Frequency Domain) Measurements	32
Using the Waveform Measurement to Set Up Triggering (for burst signals)	41
Waveform (Time Domain) Measurements	42
Modulation Analysis Measurements in 8 Steps	48
Modulation Analysis Measurement Final Checks	50
Modifying Measurement Setup Parameters	52
Using the Measurement Setup Form	52
Setting Demodulation Parameters	53
Setting up a Trigger Source	54
Setting Burst/Sync Properties	55
Using Adaptive Equalization	56
Setting Advanced Measurement Setup Properties	59
Measuring Digital Modulation Formats	62
Setting up the Modulation Analysis Personality	63
Viewing the I/Q Polar Vector and Constellation Graphs	64
Viewing the Numeric Measurement Results	66
Viewing the I/Q Error (Quad-View) Results	67
Viewing the Magnitude Error Versus Time Results	68
Viewing the Phase Error Versus Time Results	70
Viewing the EVM Versus Time Results	73
Viewing the Eye Diagram Results	75
Viewing the FSK Error (Quad-View) Results	77
Viewing the FSK Error Versus Time Results	79
Viewing the FSK Error Spectrum Results	81
Viewing the FSK Measured Time Results	83
PSK Modulation Analysis (cdma2000 QPSK Example)	85
QAM Modulation Analysis (64QAM Example)	87
EDGE Modulation Analysis	89
FSK Modulation Analysis (Bluetooth 2FSK Example)	91

Contents

MSK Modulation Analysis (GSM MSK type 1 Example)	93
Analyzing and Troubleshooting Digital Signals	95
EVM Troubleshooting Procedure Overview	95
Measurement 1 - Obtaining EVM Results with Phase Error and Magnitude Error	96
Measurement 2 - Phase Error vs. Time	97
Measurement 3 - Magnitude Error vs. Time	98
Measurement 4 - I/Q Constellation Diagram	99
Measurement 5 - Error Vector Magnitude vs. Time	101
Interpreting Measurement Results (Impairments)	102
SCPI Programming a Modulation Measurement	118
Interpreting Error Codes	119
3. Front-Panel Key and SCPI Command Reference	
Instrument Front Panel Highlights	122
Selected PSA Front-Panel Features	123
Front-Panel Keys	124
Det/Demod	124
FREQUENCY Channel	124
Input/Output	126
Meas Control	129
MEASURE	130
Mode	130
Instrument Selection by Name (Remote command only)	131
Instrument Selection by Number (Remote command only)	131
Mode Setup	131
Trig	133
Modulation Analysis Measurement Keys	141
AMPLITUDE Y Scale	141
Y Scale / Div	142
Y Ref Value	143
Y Ref Position	143
Y Scale Coupling	144
Display	144
Markers	148
Meas Setup	150
SPAN X Scale	176
Trace/View	179
SCPI only operations	180
Trig Error Offset	180
SCPI Result Table	180
Averaging	187
4. Concepts	
Introduction	190
Introduction to Digital Modulation	191
Why Choose Digital Instead of Analog Modulation?	191
What is Digital Modulation?	191
PSK examples	194

Orthogonality	195
QAM example	195
Symbol Rate.....	196
Bandwidth	196
Filtering	197
Effects Of Going Through The Origin	199
Transmitting the Digital Signal.....	200
I/Q Modulator	200
System Multiplexing.....	201
Digital Modulation Format Standards	203
Introduction.....	203
Modulation Formats and Applications	203
Families of Format and data sheets.....	203
Applications.....	204
Phase Shift Keying (PSK) Concepts.....	205
Frequency Shift Keying (FSK) Concepts	215
Minimum Shift Keying (MSK) Concepts	218
Quadrature Amplitude Modulation (QAM) Concepts.....	221
Modulation Bit State Diagrams	224
Communication System Formats	238
PSA option 241 Communications Format Standards	238
What is the cdmaOne (IS-95) Communication System?.....	239
cdmaOne Communication System	241
What is the W-CDMA Communications System?.....	242
W-CDMA Communication System.....	246
What Is the cdma2000 Communication System?.....	247
cdma2000 Communication System	250
What is the NADC Communications System?	251
NADC Communication System	254
What is the PDC Communications System?	255
PDC Communication System	256
What is the PHS Communication System.....	257
PHS Communication System	258
What is the TETRA Communications System	259
TETRA Communication System	261
What is Bluetooth?	262
Bluetooth Communication System.....	265
What are GSM and EDGE?	266
EDGE Communication System	270
What is APCO25 phase 1?	271
APCO25 phase1 Communication System	275
What is VDL Mode 3?	276
What is ZigBee (IEEE 802.15.4)?.....	277
Measurements on Digital RF Communications Systems.....	278
Introduction.....	278
Digital Modulation Analysis	278
Measurement Domains.....	279
PSA Digital Demodulator	281
Modulation quality measurements	286

Contents

Digital Modulation Errors and Signal Impairments	292
Impairments	295
Digital Modulation Displays	300
References	308
Other Sources of Digital Modulation Information	308
5. Menu Maps	
Flexible Digital Modulation Analysis Key Flow	310
Directions for Use	311

List of Commands

:CALCulate:<measurement>:MARKer[1] 2 3 4:TRACe EVM MERror PERror EIRReal EIRImag ECRMagnitude ECRPhase EVSpectrum AEVSpectrum FERRor FESpectrum AFESpectrum FMEAsured DBITs RFSPpectrum ARFSpectrum	150
:CALCulate:<measurement>:MARKer[1] 2 3 4:TRACe?	150
:CALCulate:EVM:LIMit:FERRor <frequency>.	167
:CALCulate:EVM:LIMit:FERRor:STATe ON OFF 1 0	167
:CALCulate:EVM:LIMit:FERRor:STATe?	167
:CALCulate:EVM:LIMit:FERRor?	167
:CALCulate:EVM:LIMit:RMS <real>	167
:CALCulate:EVM:LIMit:RMS:STATe ON OFF 1 0	167
:CALCulate:EVM:LIMit:RMS:STATe?	167
:CALCulate:EVM:LIMit:RMS?	167
:CALCulate:EVM:MARKer[1] 2 3 4:FUNCTion BPOWER NOISe OFF	149
:CALCulate:EVM:MARKer[1] 2 3 4:FUNCTion?	149
:CALCulate:EVM:MARKer[1] 2 3 4[:STATe] OFF ON 0 1	150
:CONFigure:EVM	180
:DISPlay:EVM:FVECTor[:STATe] OFF ON 0 1	145
:DISPlay:EVM:FVECTor[:STATe]?	145
:DISPlay:EVM:IQPoints <integer>	144
:DISPlay:EVM:IQPoints:OFFSet <integer>	145
:DISPlay:EVM:IQPoints:OFFSet?	145
:DISPlay:EVM:IQPoints?	144
:DISPlay:EVM:IQPType VCONStln VECTor CONStln	146
:DISPlay:EVM:IQPType?	146
:DISPlay:EVM:IQRotation <degree>.	147
:DISPlay:EVM:IQRotation:STATe ON OFF 1 0.	147
:DISPlay:EVM:IQRotation:STATe?	147
:DISPlay:EVM:IQRotation?	147
:DISPlay:EVM:PPSYmbol ONE TWO FOUR FIVE TEN	146
:DISPlay:EVM:PPSYmbol?	146
:DISPlay:EVM:VIEW POLar IQERror EYE FSKEError NRESults	

List of Commands

DBITs EVSPectum EQUalizer	179
:DISPlay:EVM:VIEW?	179
:DISPlay:EVM[1] 2 3 4 5 6 7 8:WINDow[1] 2 3 4:TRACe: X[:SCALe]:COUPlE OFF ON 0 1	178
:DISPlay:EVM[1] 2 3 4 5 6 7 8:WINDow[1] 2 3 4:TRACe:X[:SCALe]:COUPlE?	178
:DISPlay:EVM[1] 2 3 4 5 6 7 8:WINDow[1] 2 3 4: TRACe:X[:SCALe]:PDIVision <real>	177
:DISPlay:EVM[1] 2 3 4 5 6 7 8:WINDow[1] 2 3 4:TRACe:X[:SCALe]:PDIVision?	177
:DISPlay:EVM[1] 2 3 4 5 6 7 8:WINDow[1] 2 3 4:TRACe:X[:SCALe]:RLEVel <real>	177
:DISPlay:EVM[1] 2 3 4 5 6 7 8:WINDow[1] 2 3 4:TRACe:X[:SCALe]:RLEVel?	177
:DISPlay:EVM[1] 2 3 4 5 6 7 8:WINDow[1] 2 3 4: TRACe:X[:SCALe]:RPOSition LEFT CENTer RIGHt	178
:DISPlay:EVM[1] 2 3 4 5 6 7 8:WINDow[1] 2 3 4:TRACe:X[:SCALe]:RPOSition?	178
:DISPlay:EVM[1] 2 3 4 5 6 7 8:WINDow[1] 2 3 4:TRACe: Y[:SCALe]:COUPlE 0 1 OFF ON	144
:DISPlay:EVM[1] 2 3 4 5 6 7 8:WINDow[1] 2 3 4:TRACe:Y[:SCALe]:COUPlE?	144
:DISPlay:EVM[1] 2 3 4 5 6 7 8:WINDow[1] 2 3 4:TRACe:Y[:SCALe]:PDIVision <real>	142
:DISPlay:EVM[1] 2 3 4 5 6 7 8:WINDow[1] 2 3 4:TRACe:Y[:SCALe]:PDIVision?	142
:DISPlay:EVM[1] 2 3 4 5 6 7 8:WINDow[1] 2 3 4:TRACe:Y[:SCALe]:RLEVel <real>	143
:DISPlay:EVM[1] 2 3 4 5 6 7 8:WINDow[1] 2 3 4:TRACe:Y[:SCALe]:RLEVel?	143
:DISPlay:EVM[1] 2 3 4 5 6 7 8:WINDow[1] 2 3 4:TRACe: Y[:SCALe]:RPOSition TOP CENTer BOTTom	143
:DISPlay:EVM[1] 2 3 4 5 6 7 8:WINDow[1] 2 3 4:TRACe:Y[:SCALe]: RPOSition?	143
:FETCh:EVM[n]?	180
:INITiate:CONTInuous OFF ON	129
:INITiate:EVM	180
:INITiate:PAUSe	130
:INITiate:REStart	129
:INITiate:RESume	130
:INSTrument:NSElect 241	131
:INSTrument:NSElect?	131
:INSTrument[:SElect] SA BASIC DMODULATION	131

List of Commands

:INSTrument[:SElect]?	131
:MEASure:EVM[n]?	180
:READ:EVM[n]?	180
:TRIGger[:SEquence]:AUTO:STATe ON OFF 1 0	138
:TRIGger[:SEquence]:AUTO:STATe?	138
:TRIGger[:SEquence]:AUTO[:TIME] <time>	138
:TRIGger[:SEquence]:AUTO[:TIME]?	138
:TRIGger[:SEquence]:EXTernal[1] 2:DELAy <time>	136
:TRIGger[:SEquence]:EXTernal[1] 2:DELAy?	136
:TRIGger[:SEquence]:EXTernal[1] 2:LEVel <voltage>	137
:TRIGger[:SEquence]:EXTernal[1] 2:LEVel?	137
:TRIGger[:SEquence]:EXTernal[1] 2:SLOPe NEGative POSitive	137
:TRIGger[:SEquence]:EXTernal[1] 2:SLOPe?	137
:TRIGger[:SEquence]:FRAMe:PERiod <time>	139
:TRIGger[:SEquence]:FRAMe:PERiod?	139
:TRIGger[:SEquence]:FRAMe:SYNCmode OFF EXTFront EXTRear	140
:TRIGger[:SEquence]:FRAMe:SYNCmode:OFFSet <time>	139
:TRIGger[:SEquence]:FRAMe:SYNCmode:OFFSet?	139
:TRIGger[:SEquence]:FRAMe:SYNCmode?	140
:TRIGger[:SEquence]:HOLDoff <time>	138
:TRIGger[:SEquence]:HOLDoff?	138
:TRIGger[:SEquence]:IF:DELAy <time>	135
:TRIGger[:SEquence]:IF:DELAy?	135
:TRIGger[:SEquence]:IF:LEVel <ampl>	135
:TRIGger[:SEquence]:IF:LEVel?	135
:TRIGger[:SEquence]:IF:SLOPe NEGative POSitive	136
:TRIGger[:SEquence]:IF:SLOPe?	136
:TRIGger[:SEquence]:RFBurst:DELAy <time>	134
:TRIGger[:SEquence]:RFBurst:DELAy?	134
:TRIGger[:SEquence]:RFBurst:LEVel <rel_power>	134
:TRIGger[:SEquence]:RFBurst:LEVel?	134

List of Commands

:TRIGger[:SEQuence]:RFBurst:SLOPe NEGative POSitive	135
:TRIGger[:SEQuence]:RFBurst:SLOPe?	135
[:SENSe]:CORRection:BTS[:RF]:LOSS <real>	128
[:SENSe]:CORRection:BTS[:RF]:LOSS?	128
[:SENSe]:CORRection:MS[:RF]:LOSS <real>	128
[:SENSe]:CORRection:MS[:RF]:LOSS?	128
[:SENSe]:EVM:ADC:RANGe AUTO NONE Autopeaklock ENVL 0dB 6dB 12dB 18dB	170
[:SENSe]:EVM:ADC:RANGe?	170
[:SENSe]:EVM:ADRoop:COMPensation ON OFF 0 1	174
[:SENSe]:EVM:ADRoop:COMPensation?	174
[:SENSe]:EVM:AVERAge:COUNT <integer>	151
[:SENSe]:EVM:AVERAge:COUNT?	151
[:SENSe]:EVM:AVERAge:TCONtrol EXPonential REPeat	152
[:SENSe]:EVM:AVERAge:TCONtrol?	152
[:SENSe]:EVM:AVERAge:TRACe[:TYPE] RMS MAXimum MINimum	153
[:SENSe]:EVM:AVERAge:TRACe[:TYPE]?	153
[:SENSe]:EVM:AVERAge[:STATe] OFF ON 0 1	151
[:SENSe]:EVM:AVERAge[:STATe]?	151
[:SENSe]:EVM:CADJust <real>	168
[:SENSe]:EVM:CADJust?	168
[:SENSe]:EVM:CLOCK NORMal WIDE	165
[:SENSe]:EVM:CLOCK:WIDE:AUTO ON OFF 0 1	173
[:SENSe]:EVM:CLOCK:WIDE:AUTO?	173
[:SENSe]:EVM:CLOCK:WIDE:MRANge <freq>	174
[:SENSe]:EVM:CLOCK:WIDE:MRANge?	174
[:SENSe]:EVM:CLOCK?	165
[:SENSe]:EVM:CMODE RMS MAXimum	169
[:SENSe]:EVM:CMODE?	169
[:SENSe]:EVM:EQUalization:CONVergence <real>	164
[:SENSe]:EVM:EQUalization:CONVergence?	164
[:SENSe]:EVM:EQUalization:FLENgth <integer>	163

List of Commands

[[:SENSe]:EVM:EQUalization:FLENgth?	163
[[:SENSe]:EVM:EQUalization:HOLD[:STATe] OFF ON 0 1	164
[[:SENSe]:EVM:EQUalization:HOLD[:STATe]?	164
[[:SENSe]:EVM:EQUalization:RESet	165
[[:SENSe]:EVM:EQUalization[:STATe] OFF ON 0 1	163
[[:SENSe]:EVM:EQUalization[:STATe]?	163
[[:SENSe]:EVM:FFT:WINDow[:TYPE] UNIFORM FTOP HANNing GAUSSian	165
[[:SENSe]:EVM:FFT:WINDow[:TYPE]?	165
[[:SENSe]:EVM:IFBWidth <frequency>	166
[[:SENSe]:EVM:IFBWidth:AUTO OFF ON 0 1	166
[[:SENSe]:EVM:IFBWidth:AUTO?	166
[[:SENSe]:EVM:IFBWidth?	166
[[:SENSe]:EVM:IFPath NARROW WIDE	171
[[:SENSe]:EVM:IFPath?	171
[[:SENSe]:EVM:IUPDate ON OFF 0 1	175
[[:SENSe]:EVM:IUPDate?	175
[[:SENSe]:EVM:NORMalize:FSK ON OFF 0 1	170
[[:SENSe]:EVM:NORMalize:FSK?	170
[[:SENSe]:EVM:NORMalize:IQ MMDPoint MRMS MRDPoint	170
[[:SENSe]:EVM:NORMalize:IQ?	170
[[:SENSe]:EVM:SPECTrum NORMal INVert	168
[[:SENSe]:EVM:SPECTrum?	168
[[:SENSe]:EVM:SWEep:POINts <integer>	158
[[:SENSe]:EVM:SWEep:POINts?	158
[[:SENSe]:EVM:SYNC:SLENgth <seconds>	161
[[:SENSe]:EVM:SYNC:SLENgth?	161
[[:SENSe]:EVM:SYNC:SOURce NONE RFAMplitude SWORd SWBurst	159
[[:SENSe]:EVM:SYNC:SOURce?	159
[[:SENSe]:EVM:SYNC:STHReshold <rel_ampl>	160
[[:SENSe]:EVM:SYNC:STHReshold?	160
[[:SENSe]:EVM:SYNC:SWORd:LENgth <integer>	161

List of Commands

[:SENSe]:EVM:SYNC:SWORd:LENGth?	161
[:SENSe]:EVM:SYNC:SWORd:OFFSet <integer>	162
[:SENSe]:EVM:SYNC:SWORd:OFFSet?	162
[:SENSe]:EVM:SYNC:SWORd:PATtern <hexadecimal>	161
[:SENSe]:EVM:SYNC:SWORd:PATtern?	161
[:SENSe]:EVM:TRIGger:SOURce IMMEDIATE IF RFBURSt EXtErnal[1] EXtErnal2 FRAMe	159
[:SENSe]:EVM:TRIGger:SOURce?	159
[:SENSe]:EVM:WBIF:ADC:DITHer OFF ON 0 1	172
[:SENSe]:EVM:WBIF:ADC:DITHer?	172
[:SENSe]:EVM:WBIF:ADCCorrect OFF ON 0 1	172
[:SENSe]:EVM:WBIF:ADCCorrect?	172
[:SENSe]:EVM:WBIF:FLATness OFF ON 0 1	172
[:SENSe]:EVM:WBIF:FLATness?	172
[:SENSe]:EVM:WBIF:IFGain <integer>	171
[:SENSe]:EVM:WBIF:IFGain?	171
[:SENSe]:EVM:WBIF:TRIGger:EOFFset?	180
[:SENSe]:EVM:WBIF:TRIGger:INTerpolate OFF ON 0 1	173
[:SENSe]:EVM:WBIF:TRIGger:INTerpolate?	173
[:SENSe]:FEED RF AREFERENCE EMIXer IFALign	126
[:SENSe]:FEED?	126
[:SENSe]:FREQuency:CENTer <freq>	125
[:SENSe]:FREQuency:CENTer:STEP:AUTO OFF ON 0 1	125
[:SENSe]:FREQuency:CENTer:STEP:AUTO?	125
[:SENSe]:FREQuency:CENTer:STEP[:INCRement] <freq>	125
[:SENSe]:FREQuency:CENTer:STEP[:INCRement]?	125
[:SENSe]:FREQuency:CENTer?	125
[:SENSe]:POWer:GAIN:STATe OFF ON 0 1	128
[:SENSe]:POWer:GAIN:STATe?	128
[:SENSe]:POWer[:RF]:ATTenuation <rel_power>	127
[:SENSe]:POWer[:RF]:ATTenuation?	127

List of Commands

[[:SENSE]:POWER[:RF]:MW:PRESelector[:STATe] OFF ON 0 1	127
[[:SENSE]:POWER[:RF]:MW:PRESelector[:STATe]?	127
[[:SENSE]:RADio:DEVice BTS MS	132
[[:SENSE]:RADio:DEVice?	132
[[:SENSE]:RADio:STANdard:ALPHa	157
[[:SENSE]:RADio:STANdard:ALPHa?	157
[[:SENSE]:RADio:STANdard:FILTer:MEASurement NONE RNYQuist NYQuist GAUSSian CDMA EMF RECTangle	156
[[:SENSE]:RADio:STANdard:FILTer:MEASurement?	156
[[:SENSE]:RADio:STANdard:FILTer:REFerence RNYQuist NYQuist GAUSSian CD- MA EDGE RECTangle HSINe	156
[[:SENSE]:RADio:STANdard:FILTer:REFerence?	156
[[:SENSE]:RADio:STANdard:MODulation?	155
[[:SENSE]:RADio:STANdard:MODulation QPSK BPSK OQPSK PI4DQPSK D8PSK DQPSK EPSK QAM16 QAM32 QAM64 QAM128 QAM256 FSK2 FSK4 FSK8 MSK1 MSK2 EDGE DVBQAM16 DVBQAM32 DVBQAM64 DVBQAM128 DVBQAM256	155
[[:SENSE]:RADio:STANdard:SRATe <frequency>	157
[[:SENSE]:RADio:STANdard:SRATe?	157
[[:SENSE]:RADio:STANdard[:SELect] CDMA CDMA2K WCDMA NADC EDGE PDC TETRA GSM PHS BLUETOOTH ZigBee2450 VDLM3 APCO2 P1	132
[[:SENSE]:RADio:STANdard[:SELect]?	132

1 Introduction

This chapter provides overall information on the Agilent PSA Series Flexible Digital Modulation Analysis Option 241 and describes the measurements made by the analyzer. If you have purchased this option separately, there are installation instructions provided in this section for adding this option to your analyzer.

What Does the Agilent PSA Option 241 Do?

This instrument can help determine if a digitally modulated source or transmitter is working correctly. The instrument will demodulate a broad range of digital signals, like FSK, PSK, and QAM. Option 241 also demodulates signals created in many standard communications formats, like EDGE, cdma2000, and W-CDMA. You may alter the demodulation parameters for specialized analysis.

This instrument will demodulate signals that use the following formats:

- MSK
- QPSK
- 8PSK
- BPSK
- $\pi/4$ DQPSK
- DQPSK
- D8PSK
- Offset QPSK
- QAM16, 32, 64, 128, 256
- DVB QAM 16, 32, 64, 128, 256
- FSK 2, 4, 8 states

This instrument will also demodulate signals that conform to the following standard communications formats:

- GSM BTS and MS
- EDGE BTS and MS
- W-CDMA BTS and MS
- cdma2000 SR1 BTS and MS
- cdmaOne BTS and MS
- NADC BTS and MS
- PDC BTS and MS
- PHS BTS and MS
- TETRA BTS and MS
- Bluetooth
- ZigBee 2450 MHz

- VDL Mode 3
- APCO25 phase1

NOTE

PSA option 241 can analyze digital modulation for a single code channel only. If multiple code channels are transmitted, synchronization will fail, and incorrect EVM results will be obtained. For modulation quality measurements of multiple code channels, Modulation Accuracy and Code Domain measurements must be performed by a full-featured standard-based personality, like PSA Option BAF for W-CDMA.

For infrastructure testing and analysis, base station or mobile equipment can be tested on a non-interference basis using the appropriate power splitters, couplers, and attenuators. For details see [Chapter 2](#) , “Making Measurements,” on page 25.

Installing Optional Measurement Personalities

When you install a measurement personality, you need to follow a three step process:

1. Determine whether your memory capacity is sufficient to contain all the options you want to load. If not, decide which options you want to install now, and consider upgrading your memory. Details follow in [“Do You Have Enough Memory to Load All Your Personality Options?”](#) on page 18.
2. Install the measurement personality firmware into the instrument memory. Details follow in [“Loading an Optional Measurement Personality”](#) on page 22.
3. Enter a license key that activates the measurement personality. Details follow in [“Obtaining and Installing a License Key”](#) on page 22.

Adding measurement personalities requires the purchase of an upgrade kit for the desired option. The upgrade kit contains the measurement personality firmware and an entitlement certificate that is used to generate a license key from the internet website. A separate license key is required for each option on a specific instrument serial number and host ID.

For the latest information on Agilent Spectrum Analyzer options and upgrade kits, visit the following web location:

http://www.agilent.com/find/sa_upgrades

Do You Have Enough Memory to Load All Your Personality Options?

If you do not have memory limitations then you can skip ahead to the next section [“Loading an Optional Measurement Personality”](#) on page 22. If after installing your options you get error messages relating to memory issues, you can return to this section to learn more about how to optimize your configuration.

If you have 64 MBytes of memory installed in your instrument, you should have enough memory to install at least four optional personalities, with plenty of memory for data and states.

The optional measurement personalities require different amounts of memory. So the number of personalities that you can load varies. This is also impacted by how much data you need to save. If you are having memory errors you must swap the applications in or out of memory as needed. If you only have 48 MBytes of memory, you can upgrade your

hardware to 64 MBytes.

Additional memory can be added to any PSA Series analyzer by installing Option 115. With this option installed, you can install all currently available measurement personalities in your analyzer and still have memory space to store more state and trace files than would otherwise be possible.

To see the size of your installed memory for PSA Series Spectrum Analyzers:

1. Ensure that the spectrum analyzer is in spectrum analyzer mode because this can affect the screen size.
2. Press **System, Show System**. Under Options look for 115.
3. Press **System, More, Show Hdwr**.
4. Read Flash Memory size in the table.

PSA Flash Memory Size	Available Memory Without Option B7J and Option 122 or 140	Available Memory With Option B7J and Option 122 or 140
64 Mbytes	32.5 MBytes	30.0 MBytes
48 Mbytes	16.9 MBytes	14.3 MBytes

PSA Compact Flash Memory Size	Available Additional Memory for Measurement Personalities
512 Mbytes (Opt. 115)	512 MBytes

If you have 48 MBytes of memory, and you want to install more than 3 optional personalities, you may need to manage your memory resources. The following section, [“How to Predict Your Memory Requirements” on page 20](#), will help you decide how to configure your installed options to provide optimal operation.

How to Predict Your Memory Requirements

If you plan to install many optional personalities, you should review your memory requirements, so you can determine whether you have enough memory (unless you have a PSA Series with Option 115). There is an Agilent “Memory Calculator” available online that can help you do this, or you can make a calculated approximation using the information that follows. You will need to know your instrument’s installed memory size as determined in the previous section and then select your desired applications.

NOTE If you have a PSA Series analyzer with Option 115, there is adequate memory to install all of the available optional personalities in your instrument.

To calculate the available memory on your PSA, see:
<http://sa.tm.agilent.com/PSA/memory/>

Select the “Memory Calculator” link. You can try any combination of available personalities to see if your desired configuration is compatible with your installed memory.

NOTE After loading all your optional measurement personalities, you should have a reserve of ~2 MBytes memory to facilitate mode switching. Less available memory will increase mode switching time. For example, if you employ excessive free memory by saving files of states and/or data, your mode switching time can increase to more than a minute.

You can manually estimate your total memory requirements by adding up the memory allocations described in the following steps. Compare the desired total with the available memory that you identified in the previous section.

1. Program memory - Select option requirements from the table “Measurement Personality Options and Memory Required” on page 21.
2. Shared libraries require 7.72 MBytes.
3. The recommended mode swap space is 2 MBytes.
4. Screens - .gif files need 20-25 kBytes each.
5. State memory - State file sizes range from 21 kB for SA mode to 40 kB for W-CDMA. The state of every mode accessed since power-on will be saved in the state file. File sizes can exceed 150 kB each when several modes are accessed, for each state file saved.

TIP State memory retains settings for all states accessed before the **Save State** command. To reduce this usage to a minimum, reduce the modes accessed before the **Save State** is executed. You can set the PSA to boot into a selected mode by accessing the desired mode, then pressing the **System, Power On/Preset, Power On** keys and toggle the setting to **Last**.

Measurement Personality Options and Memory Required

Personality Options for PSA Series Spectrum Analyzers ^a	Option	File Size (PSA Rev: A.10)
cdmaOne measurement personality	BAC	1.91 Mbytes
NADC and PDC measurement personalities (not available separately)	BAE	2.43 Mbytes
W-CDMA or W-CDMA, HSDPA, HSUPA measurement personality	BAF, 210	5.38 Mbytes ^b
cdma2000 or cdma2000 w/ 1xEV-DV measurement personality	B78, 214	4.00 Mbytes ^b
1xEV-DO measurement personality	204	5.61 Mbytes ^b
GSM (with EDGE) measurement personality	202	3.56 Mbytes ^b
Shared measurement library ^b	n/a	7.72 Mbytes
Phase Noise measurement personality	226	2.82 Mbytes ^c
Noise Figure measurement personality	219	4.68 Mbytes ^c
Basic measurement personality with digital demod hardware	B7J	Cannot be deleted (2.64 Mbytes)
Programming Code Compatibility Suite ^d (8560 Series, 8590 Series, and 8566/8568)	266	1.18 Mbytes ^c
TD-SCDMA Power measurement personality	211	5.47 Mbytes ^c
TD-SCDMA Modulation Analysis or TD-SCDMA Modulation Analysis w/ HSDPA/8PSK measurement personality	212, 213	1.82 Mbytes
Flexible Digital Modulation Analysis	241	2.11 Mbytes ^b
WLAN measurement personality	217	3.24 Mbytes ^b
External Source Control	215	0.72 Mbytes ^c
Measuring Receiver Personality (available with Option 23A - Trigger support for AM/FM/PM and Option 23B - CCITT filter)	233	2.91 Mbytes ^b
EMC Analyzer	239	4.06 Mbytes ^b

- a. Available as of the print date of this guide.
- b. Many PSA Series personality options use a 7.72 Mbyte shared measurement library. If you are loading multiple personalities that use this library, you only need to add this memory allocation once.
- c. Shared measurement library allocation not required.
- d. This is a no charge option that does not require a license key.

Memory Upgrade Kits

The PSA 64 MByte Memory Upgrade kit part number is E4440AU-ANE. The PSA Compact Flash Upgrade kit part number is E4440AU-115.

For more information about memory upgrade kits contact your local sales office, service office, or see:

http://www.agilent.com/find/sa_upgrades

Loading an Optional Measurement Personality

You must use a PC to load the desired personality option into the instrument memory. Loading can be done from a firmware CD-ROM or by downloading the update program from the internet. An automatic loading program comes with the files and runs from your PC.

You can check the Agilent internet website for the latest PSA firmware versions available for downloading:

http://www.agilent.com/find/psa_firmware

NOTE

When you add a new option, or update an existing option, you will get the updated versions of all your current options as they are all reloaded simultaneously. This process may also require you to update the instrument core firmware so that it is compatible with the new option.

Depending on your installed hardware memory, you may not be able to fit all of the available measurement personalities in instrument memory at the same time. You may need to delete an existing option file from memory and load the one you want. Use the automatic update program that is provided with the files. Refer to the table showing “[Measurement Personality Options and Memory Required](#)” on page 21. The approximate memory requirements for the options are listed in this table. These numbers are worst case examples. Some options share components and libraries, therefore the total memory usage of multiple options may not be exactly equal to the combined total.

Obtaining and Installing a License Key

If you purchase an optional personality that requires installation, you will receive an “Entitlement Certificate” which may be redeemed for a license key specific to one instrument. Follow the instructions that accompany the certificate to obtain your license key.

To install a license key for the selected personality option, use the following procedure:

NOTE

You can also use this procedure to reinstall a license key that has been deleted during an uninstall process, or lost due to a memory failure.

1. Press **System, More, More, Licensing, Option** to access the alpha editor. Use this alpha editor to enter letters (upper-case), and the front-panel numeric keys to enter numbers for the option designation. You will validate your option entry in the active function area of the display. Then, press the **Enter** key.
2. Press **License Key** to enter the letters and digits of your license key. You will validate your license key entry in the active function area of the display. Then, press the **Enter** key.
3. Press the **Activate License** key.

Viewing a License Key

Measurement personalities purchased with your instrument have been installed and activated at the factory before shipment. The instrument requires a **License Key** unique to every measurement personality purchased. The license key is a hexadecimal number specific to your measurement personality, instrument serial number and host ID. It enables you to install, or reactivate that particular personality.

Use the following procedure to display the license key unique to your personality option that is already installed in your PSA:

Press **System, More, More, Licensing, Show License**. The **System, Personality** key displays the personalities loaded, version information, and whether the personality is licensed.

NOTE

You will want to keep a copy of your license key in a secure location. Press **System, More**, then **Licensing, Show License**, and print out a copy of the display that shows the license numbers. If you should lose your license key, call your nearest Agilent Technologies service or sales office for assistance.

Using the Delete License Key on PSA

This key will make the option unavailable for use, but will not delete it from memory. Write down the 12-digit license key for the option before you delete it. If you want to use that measurement personality later, you will need the license key to reactivate the personality firmware.

NOTE

Using the **Delete License** key does not remove the personality from the instrument memory, and does not free memory to be available to install another option. If you need to free memory to install another option, refer to the instructions for loading firmware updates located at the URL : <http://www.agilent.com/find/psa/>

1. Press **System, More, More, Licensing, Option**. Pressing the **Option** key will activate the alpha editor menu. Use the alpha editor to enter the

letters (upper-case) and the front-panel numeric keyboard to enter the digits (if required) for the option, then press the **Enter** key. As you enter the option, you will see your entry in the active function area of the display.

2. Press **Delete License** to remove the license key from memory.

Ordering Optional Measurement Personalities

When you order a personality option, you will receive an entitlement certificate. You will need to go to the Web site to redeem your entitlement certificate for a license key. You will need to provide your instrument serial number and host ID, and the entitlement certificate number.

Required Information:	Front Panel Key Path:
Model #: (Ex. E4440A)	
Host ID: _____	System, Show System
Instrument Serial Number: _____	System, Show System

2

Making Measurements

This chapter describes procedures used to set up and analyze digitally modulated signals. Details of the steps necessary for accurate modulation analysis of digital signals are provided, and examples of the measurement capability of PSA Option 241 for analysis of various modulation formats are shown.

Introduction

This chapter provides measurement and troubleshooting procedures and also shows example results obtained using the PSA Option 241 Flexible Digital Modulation Analysis measurement personality. When correctly set up, this PSA personality demodulates basic formats, cellular formats, and wireless connectivity formats and performs a suite of vector-analysis measurements to analyze digital modulation quality.

There are three measurements available in this mode: Modulation Analysis, Spectrum, and Waveform. This chapter concentrates on the Modulation Analysis measurement. For more details about Spectrum and Waveform measurements, please refer to the PSA Basic Mode Guide.

NOTE

PSA option 241 can analyze digital modulation for a single code channel only. If multiple code channels are transmitted, synchronization will fail, and incorrect EVM results will be obtained. For modulation quality measurements of multiple code channels, Modulation Accuracy and Code Domain measurements must be performed by a full-featured standard-based personality, like PSA Option BAF for W-CDMA.

The following PSA hardware options are compatible with this measurement personality, as well as for Basic Mode Spectrum and Waveform measurements:

- Option 122, 80 MHz Bandwidth Digitizer
- Option 140, 40 MHz Bandwidth Digitizer
- Option 123, Preselector Bypass (required for Options 122 or 140)

For more information on using Options 122, 123, and 140 see the PSA Basic Mode Guide.

The following subjects are presented in this chapter:

- [“Setting Up the Test Equipment and DUT” on page 28](#)

This section describes how to setup your test equipment and DUT to make modulation measurements on the PSA. It also describes instrument preset types.

- [“Determining the RF Parameters of Your Signal” on page 31](#)

This section describes how to use the spectrum and waveform measurements to view the RF parameters of your signal.

- [“Modulation Analysis Measurements in 8 Steps” on page 48](#)

This section describes steps to set up the PSA to demodulate industry standard radio formats or to use the flexible modulation

settings to demodulate customized digital signals.

- [“Modulation Analysis Measurement Final Checks” on page 50](#)
This section describes what you should expect from a modulation analysis measurement and tips to improve your measurement.
- [“Modifying Measurement Setup Parameters” on page 52](#)
This section describes how to setup demodulation parameters, triggering, burst synchronization and equalization.
- [“Measuring Digital Modulation Formats” on page 62](#)
This section describes the different modulation analysis views using industry standard communication formats.
- [“Analyzing and Troubleshooting Digital Signals” on page 95](#)
This section describes a troubleshooting procedure to determine the causes of impairments that degrade signal quality.
- [“Interpreting Error Codes” on page 119](#)
This section details common error messages and offers hints to assist you in resolving them.

Setting Up the Test Equipment and DUT

Making the Initial Signal Connection

CAUTION

Before connecting a signal to the instrument, make sure the instrument can safely accept the signal level provided. The signal level limits are marked next to the connectors on the front panel.

See “[Input/Output](#)” on page 126 for details on selecting input ports, setting internal attenuation to prevent overloading the input port, and details of **Int Preamp** operation.

Configuring a MS Measurement System

The mobile station (MS) under test has to be set to transmit the RF power remotely through the system controller. This transmitting signal is connected to the instruments RF input port. Connect the equipment as shown.

Figure 2-1 Mobile Station Measurement System

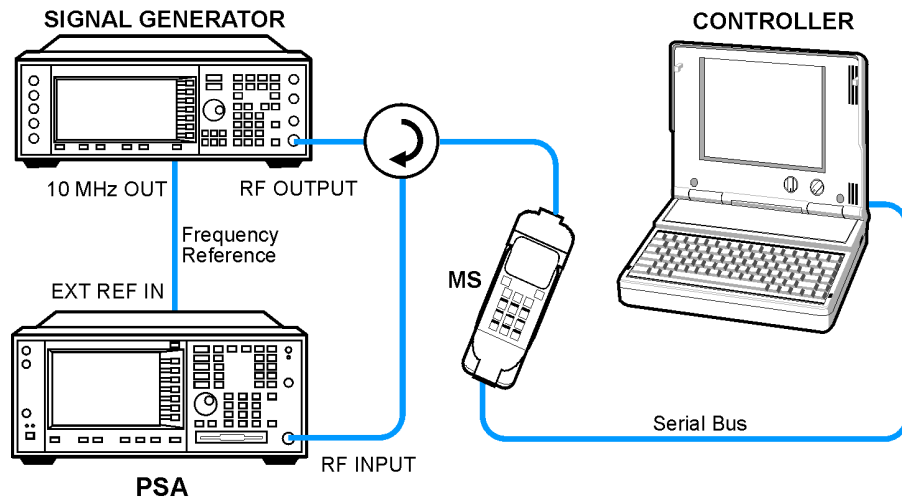

- Step 1.** Using the appropriate cables, adapters, and circulator, connect the output signal of the MS to the RF input of the instrument.
- Step 2.** Connect the base transmission station simulator or signal generator to the MS through a circulator to initiate a link constructed with sync and pilot channels, if required.
- Step 3.** Connect a BNC cable between the 10 MHz OUT port of the signal generator and the EXT REF IN port of the instrument.
- Step 4.** Connect the system controller to the MS through the serial bus cable to control the MS operation.

Configuring a BTS Measurement System

The base transmission station (BTS) under test has to be set to transmit the RF power remotely through the system controller. The transmitting signal from the BTS is summed with the interferer and connected to the instruments RF input port. Connect the equipment as shown.

Figure 2-2

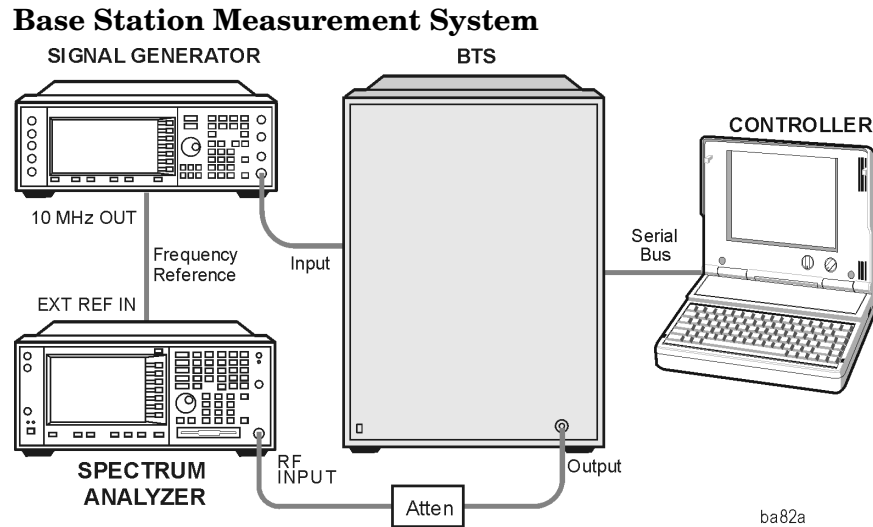

- Step 1.** Using appropriate amplifier, circulators, etc., connect the RF uplink signal from a signal generator or MS to the BTS RF Input connector.
- Step 2.** Connect the RF Output signal from the BTS to the RF Input port of the instrument through an attenuator.
- Step 3.** Connect a BNC cable between the 10 MHz OUT port of the signal generator and the EXT REF IN port of the instrument.
- Step 4.** Connect the system controller to the BTS with the serial bus cable.

NOTE

When making BTS or MS measurements, you may need to provide a synchronization trigger to the PSA. Selections are detailed in the section [“Setting up a Trigger Source” on page 54](#) (connections not shown).

Using Instrument Presets

If you want to set your current measurement personality to a known, factory default state use instrument preset. You have the option of setting the instrument preset to factory, mode or user defined preset types. To restore the PSA default settings in the **Modulation Analysis** mode, use **Mode** preset to initialize the modulation parameters and retain the current mode.

Step 1. Select the preset type:

Press **System, Power On/Preset, Preset Type**.
Press **User** or **Mode** or **Factory**.

Factory Preset - Returns the analyzer to **Spectrum Analysis** mode (if the current mode is not spectrum analysis) and initializes the instrument settings to factory settings in **Spectrum Analysis** mode.

Mode Preset - The analyzer is preset within its current mode. Instrument settings are reset to a factory default state for the current mode.

User Preset - The instrument is preset to a saved configuration.

Step 2. Save a user defined preset state:

Press **System, Power On/Preset, Save User Preset**.

The PSA can save one user defined preset state. When user preset is selected and **Preset** is pressed, the analyzer will prompt you to select user, mode or factory preset. When in mode and factory preset the analyzer will not prompt you to choose the preset type.

Determining the RF Parameters of Your Signal

This procedure uses the spectrum and waveform measurements in the PSA Option 241 modulation analysis measurement personality to help determine the RF parameters of your signal. The spectrum measurement is used to view the signal in the frequency domain, verifying the center frequency of the carrier and the frequency span of the signal. The waveform measurement is used to view the signal in the time domain and is very useful for determining trigger conditions.

NOTE

The spectrum and waveform measurements available in PSA Option 241 are the same as those available in basic mode. Spectrum and waveform measurements are provided in the modulation analysis mode for your convenience to avoid having to switch to basic mode for their use. Please refer to the *PSA Basic Mode User's Guide Option B7J* for more detail on the spectrum and waveform measurements, remote commands, front-panel keys, conceptual information and menu maps.

Using the Spectrum Measurement to View the RF Parameters of the Signal Under Test

The spectrum measurement is the default measurement for PSA Option 241. Use the spectrum view to make sure your demodulation measurement is focused on your signal of interest.

Step 1. Activate the spectrum measurement view:

Press **MODE, Digital Modulation**.
Press **MEASURE, Spectrum (Freq Domain)**.

Step 2. Set the center frequency to your signal's carrier frequency:

Press **FREQUENCY Channel**, then use the front-panel keypad to input the center frequency, then press a units key, like **GHz**, to complete the entry.

Step 3. Set the frequency span to view your entire signal:

Press **SPAN X Scale**, then use the front-panel keypad to input the frequency span, then press a units key, like **MHz**, to complete the entry.

When Option 123, Preselector Bypass is installed, along with either PSA Option 122, 80 MHz Bandwidth Digitizer hardware, or PSA Option 140, 40 MHz Bandwidth Digitizer hardware, together they may be used to increase the capture bandwidth of signals. Press **Meas Setup, More, IF Path**, and toggle the setting to **Wide** to increase the available IF bandwidth of the instrument. See [“Wideband Setup” on page 171](#) for more details of using the wideband IF path.

CAUTION

Make sure your signal is not overloading the instrument. If the Input Overload annunciator is active at the lower left edge of the spectrum display, adjust the RF input power, or the internal attenuation as needed.

Check: The signal's spectrum should appear as a distinct, elevated region of noise 20 dB or more above the analyzer noise floor. If your signal is not significantly above the measurement noise floor, you may need to modify your measurement configuration by adding amplification. Broad, glitching sidebands indicate bursts or other transients, which can be handled with triggering or the Sync Search function (see [“Setting Burst/Sync Properties” on page 55](#)).

Spectrum (Frequency Domain) Measurements

This section explains how to make a frequency domain measurement on a cellular base station. An adjacent or an interfering signal can also be applied, if desired, during spectrum measurements.

If installed, you may use PSA Option 122, the 80 MHz Bandwidth Digitizer hardware, or PSA Option 140, the 40 MHz Bandwidth Digitizer hardware to perform Spectrum measurements of wideband signals using Basic Mode.

Configuring the Measurement System

This example shows a base station (BTS) under test, set up to transmit RF power, and being controlled remotely by a system controller. The transmitting signal is connected to the analyzer RF input port. Connect the equipment as shown.

Figure 2-3 Spectrum Measurement System

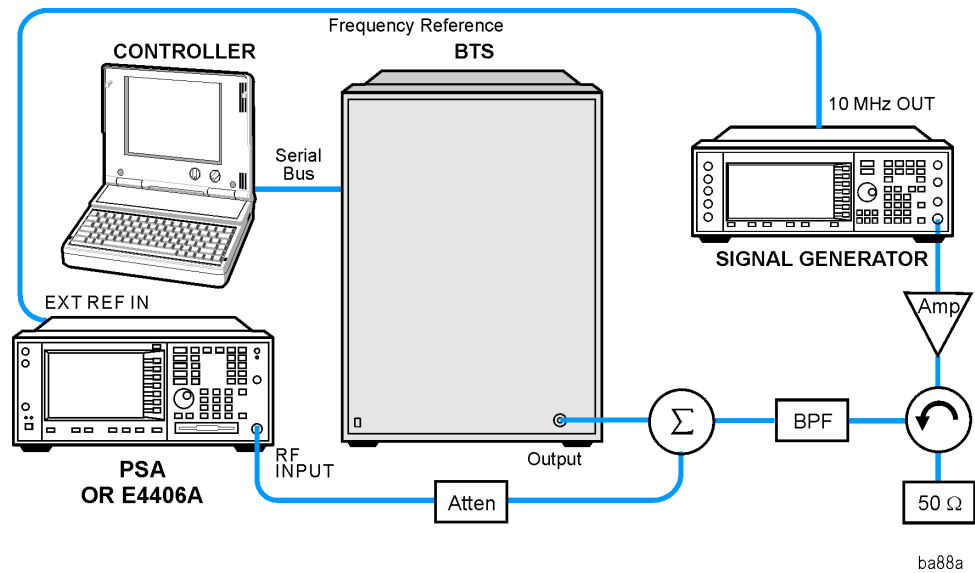

1. Using the appropriate cables, adapters, and circulator, connect the output signal of the BTS to the RF input of the instrument.
2. Connect the base transmission station simulator or signal generator to the BTS through a circulator to initiate a link constructed with sync and pilot channels, if required.
3. Connect a BNC cable between the 10 MHz OUT port of the signal generator and the EXT REF IN port of the instrument.
4. Connect the system controller to the BTS through the serial bus cable to control the BTS operation.

Setting the BTS

From the base transmission station simulator and the system controller, set up a call using loopback mode to allow the BTS to transmit an RF signal.

Measurement Procedure

- Step 1.** Press **Preset** to preset the instrument.
- Step 2.** Press **MODE**, **Digital Modulation** to enable the **Digital Modulation Mode** measurements.
- Step 3.** To set the measurement center frequency, press **FREQUENCY Channel** and enter a numerical frequency using the front-panel keypad. Complete the entry by selecting a units key, like **MHz**.
- Step 4.** Press **SPAN** and enter a numerical span using the front-panel keypad.

Press **MHz** to set the measurement span in MHz.

Step 5. Press **MEASURE** to initiate the Spectrum measurement, which is the default measurement for the selected Mode.

NOTE

A display with both a Spectrum window and an I/Q Waveform window will appear when you activate a Spectrum measurement. The active window is outlined in green. Changes to **FREQUENCY**, **Span**, or **Amplitude** settings will affect only the active window. Use the **Next Window** key to select a different window, and the **Zoom** key to enlarge a window.

The default display shows both **Current** (yellow trace) and **Average** (blue trace) data. To make viewing the display easier, you can view either the **Current** trace or **Average** separately.

- Press **Trace/View**, **Trace Display**, and select the trace(s) desired for display.

Figure 2-4 Spectrum Measurement - Spectrum and I/Q Waveform (Default View)

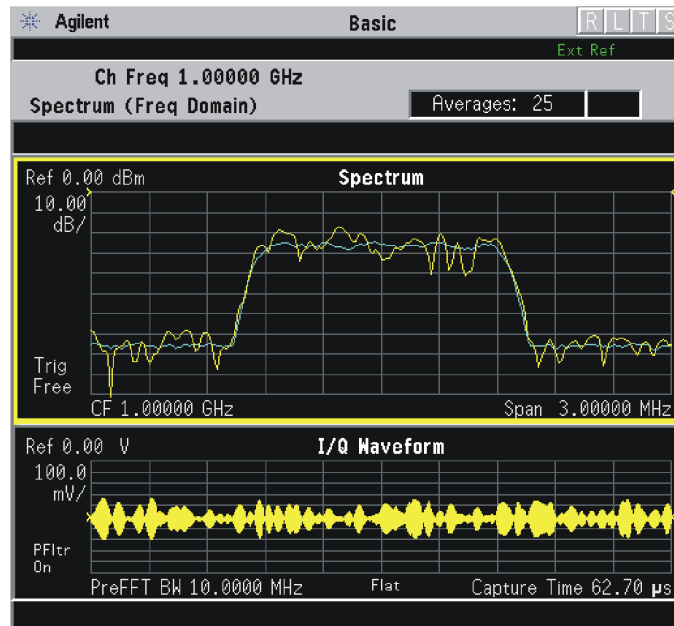

Step 6. Press **View/Trace** to display a menu allowing selection of another measurement result display, including the following:

- **Spectrum** - Provides a combination view of the Spectrum graph in parameters of power versus frequency with semi-log graticules, and the I/Q waveform graph in parameters of voltage and time. Changes to the frequency span or power will sometimes affect data acquisition. This is equivalent to changing the selected window with the **Next Window** key.

Spectrum (Time Domain) I/Q Waveform - This graph is shown below the Spectrum graph in the default dual-window display. I/Q Waveform provides a view of the I/Q waveform in parameters of voltage versus time in linear scale. Changes to sweep time or resolution bandwidth can affect data acquisition.

Figure 2-5 Spectrum (Time Domain) Measurement - I/Q Waveform Result

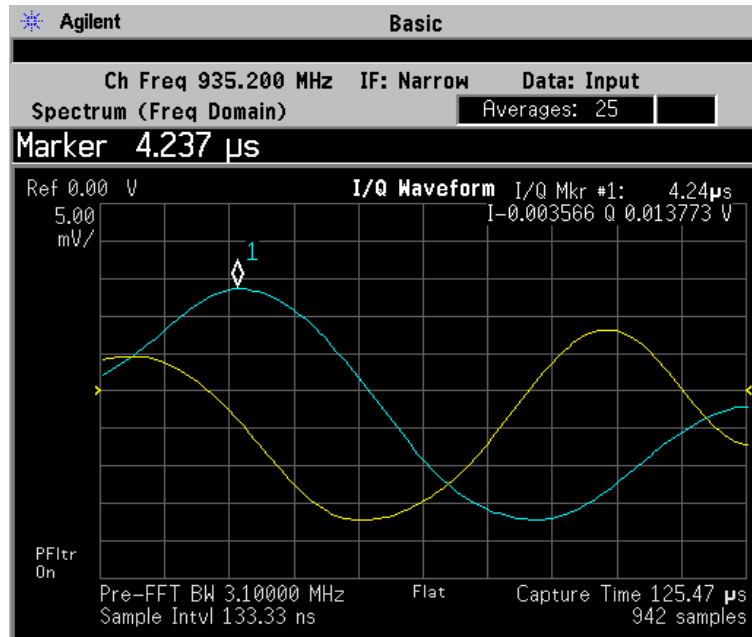

Step 7. To make a measurement repeatedly, press **Meas Control, Measure** to toggle the setting from **Single** to **Cont.**

Step 8. For PSA, if Option 122 or 140 is installed, you may use the wideband IF hardware to view a wide bandwidth signal in the Spectrum view. The I/Q Waveform view will be correctly demodulated to the I and Q components over the entire display bandwidth.

- Press **MODE**, and select Modulation Analysis to be able to use the Wideband IF path.
- Press **MEASURE**, and select the **Spectrum** measurement.
- Press **MEAS SETUP** and toggle the **IF Path** key to select **Wide**. Adjust the span to view up to 80 MHz for Option 122, or up to 40 MHz for Option 140 around your selected center frequency.

The example shown below is a 54 carrier OFDM signal which has a – 10 dB bandwidth greater than 16 MHz, with skirts to over twice that bandwidth. Delta markers are shown measuring the peak bandwidth.

Figure 2-6 Spectrum Measurement - Spectrum Zoom View with Opt. 122–80 MHz Bandwidth Digitizer Hardware

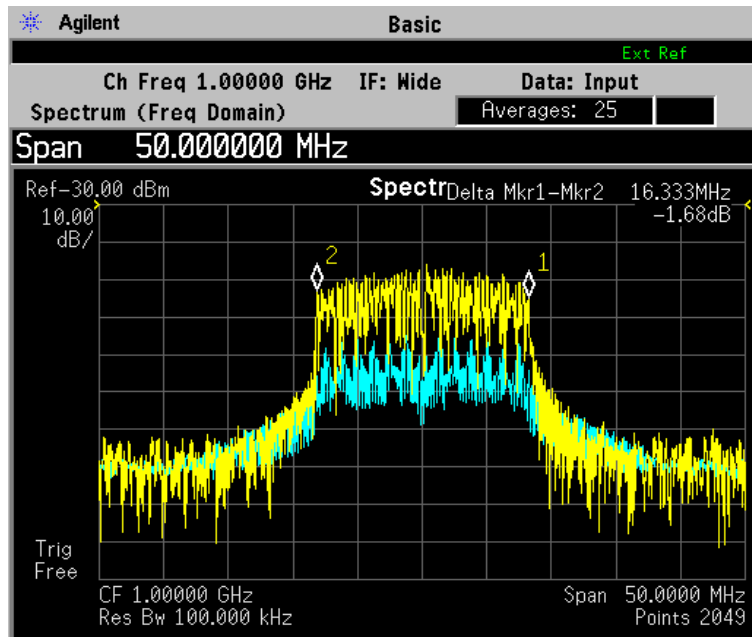

The example shown below is a 802.11 WLAN signal which has an instantaneous bandwidth of over 36 MHz. Only the Average trace is displayed.

When using the widest spans, the Resolution Bandwidth may be limited by the maximum number of points available for a Spectrum measurement. If your desired setting exceeds the available number of points, the maximum number available will be used, and an error message will be displayed.

Figure 2-7 Spectrum Measurement - Spectrum Zoom View with Opt. 122–80 MHz Bandwidth Digitizer Hardware

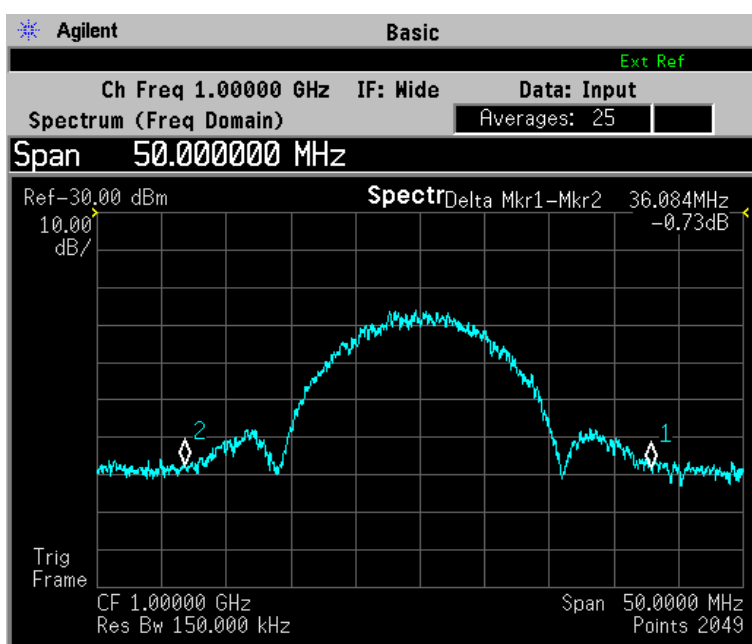

The example shown below is a Spectrum View of the center 20 MHz of a Noise Power Ratio measurement. If you extend the Span to the full 80 MHz bandwidth, individual carriers displayed may merge, as they can be limited by screen resolution and resolution bandwidth. Only the Average data trace is displayed in the example below.

Figure 2-8 Spectrum Measurement - Spectrum View with Opt. 122– 80 MHz Bandwidth Digitizer Hardware

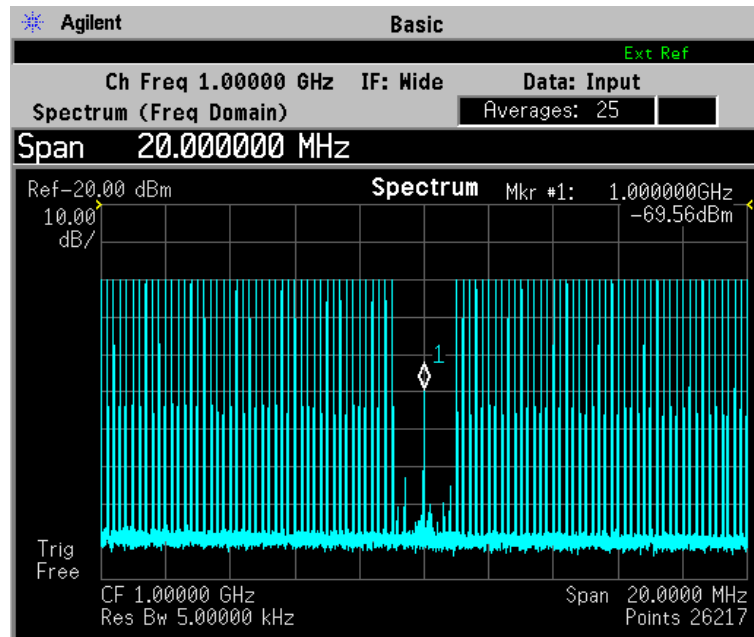

The wideband signal example shown below is 16 W-CDMA carriers, each occupying 5 MHz of bandwidth. The full 80 MHz of available demodulation bandwidth for the Spectrum measurement is used. Only the Average trace is displayed. Note the demodulated composite I/Q waveform for the entire 80 MHz BW signal in the **I/Q Waveform** window below. A peak search marker has been applied to the composite waveform.

Figure 2-9 Spectrum Measurement - Spectrum Zoom View with Opt. 122–80 MHz Bandwidth Digitizer Hardware

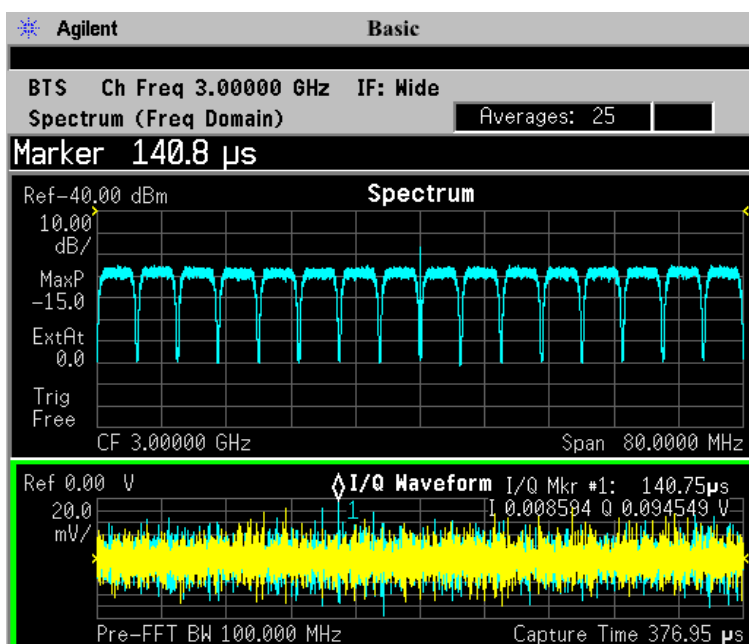

Step 9. Press **Meas Setup, More** to check the keys available to change the measurement parameters from the default condition.

For more details about using PSA Wide Bandwidth BW Digitizing Hardware Options 122 and 140, including detailed functional descriptions and SCPI commands and concepts, see the PSA Basic Mode Guide.

Using the Waveform Measurement to Set Up Triggering (for burst signals)

You can use the waveform measurement to view your signal in the time domain and to help select the appropriate trigger to acquire your signal.

Step 1. Activate the waveform measurement view:

Press **MEASURE, Waveform (Time Domain)**.

Step 2. Adjust the scale of the x-axis to view the complete signal waveform:

Press **SPAN X Scale, Scale/Div**, then use the front-panel keypad to input the scale/div, then press a units key, like μs , to complete the entry.

Step 3. Select a trigger source (free run is the default setting):

Press **Meas Setup, Trig Source**, then select one of the available trigger sources.

Triggering is unnecessary for most signals. For TDMA and other burst signals, PSA Option 241 will readily acquire a “framed” signal.

NOTE

In the waveform measurement the **Burst/Sync Search** menu is not available. **Burst/Sync Search** is available in the **Modulation Analysis** measure mode. **Frame Timer** (located under the **Trig Setup** menu) must be used to trigger on framed signals in the **Waveform** measurement.

Step 4. Set up the trigger conditions:

Press **Trig** or **Mode Setup, Trigger Setup**, then choose a trigger mode.

In the trigger mode set the delay, peak level and positive or negative edge slope trigger. You can also set up trigger holdoff, auto trigger timing and frame timer settings.

NOTE You can modify the trigger setup settings in an editable table view under the **Mode Setup, Trigger Setup...** key. You may select any parameter to change the settings by pressing the Left/Right Arrow keys. The current selection is highlighted in yellow or blue. You may use the Up/Down Arrow keys, front-panel knob or the front-panel keypad to input changes to the selected field.

Waveform (Time Domain) Measurements

This section explains how to make Waveform (Time Domain) measurements on a cellular base station. Measurement of I and Q modulated waveforms in the time domain disclose the voltages which comprise the complex modulated waveform of a digital signal.

If installed, you may use PSA Option 122, the 80 MHz Bandwidth Digitizer hardware, or PSA Option 140, the 40 MHz Bandwidth Digitizer hardware to perform Waveform measurements of wideband signals using Basic Mode.

Configuring the Measurement System

The base station (BTS) under test has to be set to transmit the RF power remotely through the system controller. This transmitting signal is connected to the instruments RF input port. Connect the equipment as shown. An interfering or adjacent signal may supplied as shown.

From the base transmission station simulator (signal generator) and the system controller, set up a call using loopback mode for the MS to transmit the RF signal.

Figure 2-10 Waveform Measurement System

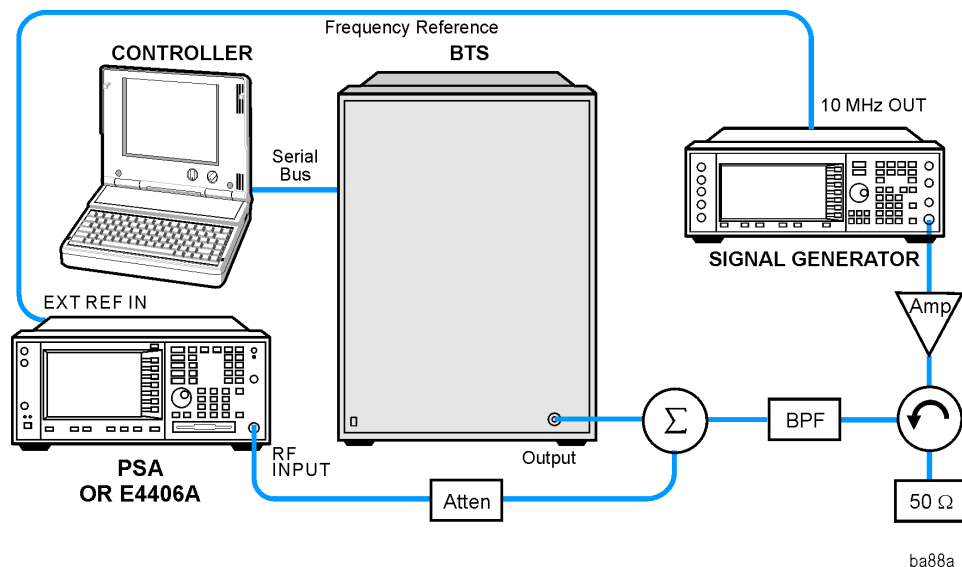

1. Using the appropriate cables, adapters, and circulator, connect the output signal of the BTS to the RF input of the instrument.
2. Connect the base transmission station simulator or signal generator to the BTS through a circulator to initiate a link constructed with sync and pilot channels, if required.
3. Connect a BNC cable between the 10 MHz OUT port of the signal generator and the EXT REF IN port of the instrument.
4. Connect the system controller to the BTS through the serial bus cable to control the BTS operation.
5. Connect an external trigger, if needed. Press Mode Setup, Trigger to access a menu to set up inputs and levels for all triggers. You must then select the appropriate trigger under the Meas Setup, Trigger menu to direct the measurement to use your trigger settings.

Setting the BTS From the mobile simulator (signal generator) and the system controller, set up a call using loopback mode for the BTS to transmit the RF signal.

Measurement Procedure

- Step 1.** Press **Preset** to preset the instrument.
- Step 2.** Press **MODE**, **Digital Modulation** key to enable the **Digital Modulation** Mode measurements.
- Step 3.** To set the measurement center frequency, press **FREQUENCY Channel** and enter a numerical frequency using the front-panel keypad. Complete the entry by selecting a units key, like **MHz**.
- Step 4.** Press **SPAN** and enter a numerical span using the front-panel keypad. Press **MHz** to set the measurement span in MHz.
- Step 5.** Press **MEASURE** to initiate the Waveform measurement.

The default display shows both **Current** (yellow trace) and **Average** (blue trace) data. To make viewing the display easier, you can view either the **Current** or **Average** trace separately.

- Press **Trace/View**, **Trace Display**, and select the trace(s) desired for display.

- Step 6.** Press **SPAN X Scale**, and the up or down arrow key until the waveform is shown at a convenient time scale for viewing.

If installed, you may use the 80 MHz Bandwidth hardware to view a wideband signal in the RF Envelope view.

Press **SPAN** and select the **Wideband** RF Path. Adjust the span to view up to 80 MHz around your selected center frequency.

The following figure shows an example of an **RF Envelope** result for a Waveform (Time Domain) measurement. The measured values for the

mean power and peak-to-mean power are shown in the text window.

Figure 2-11 Waveform Measurement - RF Envelope (Default View)

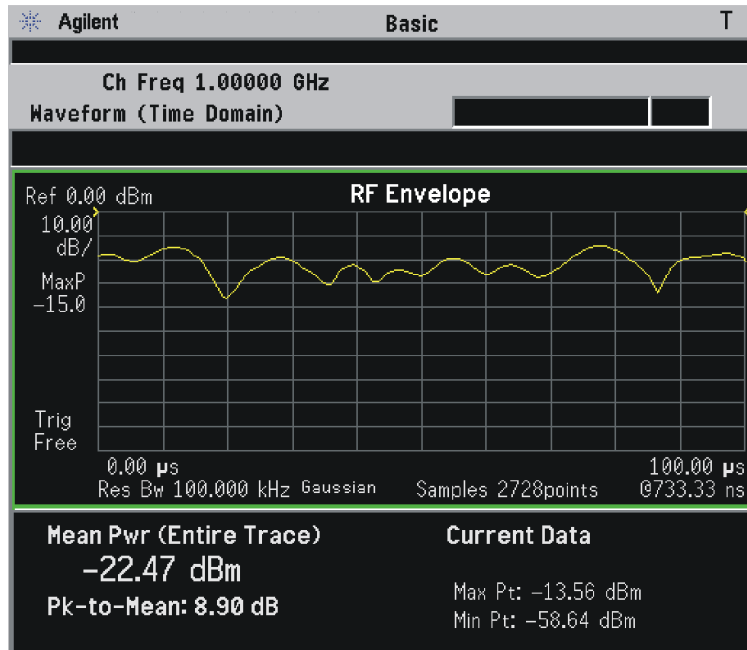

Step 7. Press **Trace/View** to display the menu allowing selection of the other Waveform views, including the following:

- **I/Q Waveform** - Provides a view of the I and Q waveforms together on the same graph in parameters of voltage versus time in linear scale. Changes to the sweep time or resolution bandwidth can affect data acquisition.

Step 8. If PSA Option 140 or 122 is installed, you may use the 40 or 80 MHz Bandwidth hardware to view a wideband signal in the Waveform view. Even if you are not interested in a wideband signal, using the Wideband IF path provides powerful measurement flexibility, including to the ability to accurately set practically any sample rate and thereby resample waveforms. Resampling, or oversampling, at the correct rate allows you to effectively obtain an integer number of samples per symbol. Make sure that the sample time is aligned with the decision points of the symbols to make analysis of measurement data much easier.

The following example of performing a Wideband IF Waveform measurement of a GSM burst will show the technique to accurately align and resample a signal:

- Press **Mode**, and select **Modulation Analysis** to be able to use the 80 MHz IF path.
- Press **MEASURE**, and select the **Waveform** measurement.

- Press **Trace/View** and select the **RF Envelope** view.
- Press **SPAN** and toggle the **IF Path** key to select **Wide**. Adjust the span to view up to 80 MHz around your selected center frequency. Note the example below has 1 million data points.

Figure 2-12 Waveform Measurement - RF Envelope View with Opt. 122– 80 MHz Bandwidth Digitizer Hardware

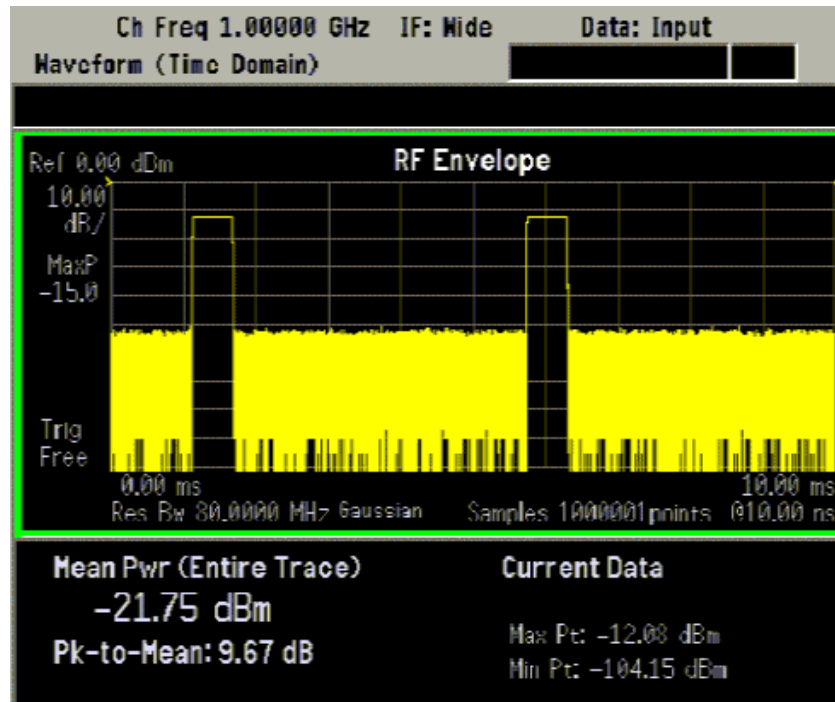

- Make sure that your samples are synchronized to the decision points of the signal of interest. In this case we will use the internal Frame Timer to trigger our measurement. A GSM frame is 4.615383 ms long.

Press **Mode Setup, Trigger**, select **Frame Timer**, then select **Period**. Enter 4.615383 ms. This only sets the frame timer period. You must direct the measurement to use the Frame Timer in the next step:

Press **Meas Setup, Trigger Source** and select **Frame**.

For other measurements, an external trigger may be applied to an External Trigger Input, on either the front or the rear panel. You must specify that trigger selection in this menu.

- In this example, we want to capture an entire GSM burst of 144 symbols (plus guard). A GSM burst is approximately 4.6 ms, so we will set our **Meas Time** to 5 ms:

Press **Meas Setup, Meas Time** and enter 5 ms.

- In this resampling example, we want to take exactly 10 samples per GSM symbol. The GSM symbol rate is 270.833 kHz, so we want a sample rate of 2.70833 MHz. Option 122 Wideband IF hardware lets us set the desired sample rate, as follows: $\text{sample rate} = 5/4 \text{ IF Bandwidth}$. That means we need set an IF BW of 2.16667 MHz.

Press **Meas Setup, IF BW** and enter 2.16667 MHz.

You can also access the sample rate key directly:

Press **Meas Setup, Wideband Setup, Sample Rate**. Enter the **Sample Rate** frequency. The **Sample Rate** and **IF BW** settings are coupled. The 5/4 ratio will be preserved regardless of which setting is used.

Figure 2-13 Waveform Measurement - RF Envelope View with Opt. 122–80 MHz Bandwidth Digitizer Hardware

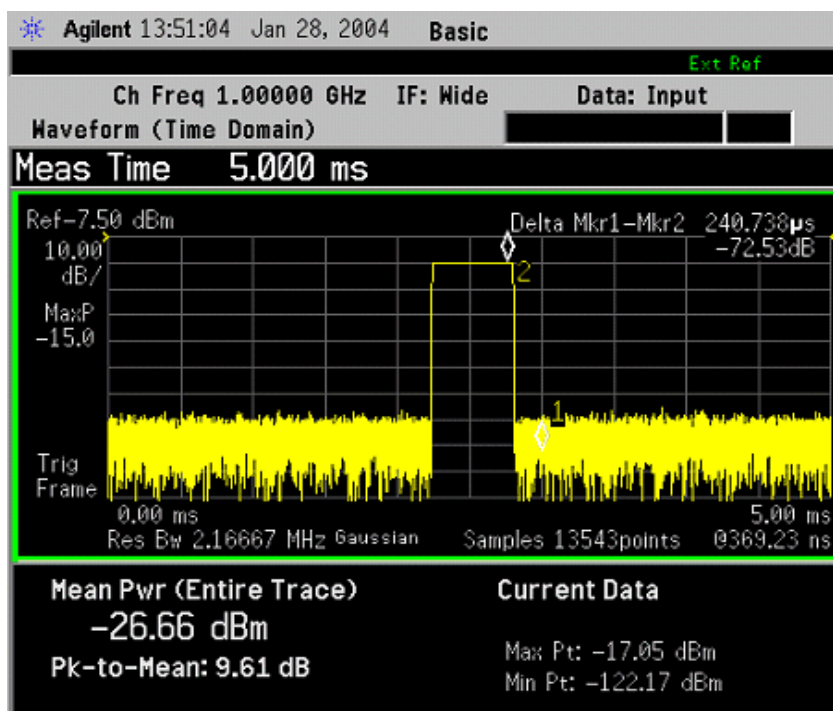

For more details about making wideband measurements, see “PSA Option 122 Wideband Digitizer” in the Option 122 section in the “PSA Basic Mode Guide.”

- Step 9.** Press **AMPLITUDE Y Scale** and the up arrow or down arrow key until the waveforms are shown at a convenient voltage scale for viewing.
- Step 10.** Press **SPAN X Scale** and the up arrow or down arrow key until the waveforms are shown at a convenient time scale for viewing.

- Step 11.** Press **Marker, Trace, I/Q Waveform** to activate a marker. Rotate the **RPG** knob until the marker is shown at a desired time in the waveform for viewing the trace values at the time position of the marker.
- Step 12.** To make a measurement repeatedly, press **Meas Control, Measure** and toggle to **Cont**.
- Step 13.** Press **Meas Setup, More** to check the keys available to change the measurement parameters from the default condition.

Using the Waveform Measurement to Set Up Triggering (for burst signals)

You can use the Waveform measurement to view your signal in the time domain and to help select the appropriate trigger to acquire your signal.

- Step 1.** Press **MEASURE, Waveform (Time Domain)** to activate the Waveform measurement view.
- Step 2.** Press **SPAN X Scale, Scale/Div** to adjust the scale of the x-axis to view the complete signal waveform. Use the front-panel keypad to input the **scale/div**, then press a units key, like μs , to complete the entry.
- Step 3.** Press **Meas Setup, Trig Source**, then select one of the available trigger sources (free run is the default setting).

NOTE

In the Waveform measurement, the **Burst/Sync Search** menu is not available. **Burst/Sync Search** is available in the **Modulation Analysis** measurement mode. **Frame Timer** (located under the **Trig Setup** menu) must be used to trigger on framed signals in the **Waveform** measurement.

- Step 4.** Press **Trig**, then choose a trigger mode to set up the trigger conditions.

In the trigger mode, set the delay, peak level, and positive or negative edge slope trigger. You can also set up trigger holdoff, auto trigger timing, and frame timer settings.

For more details about using PSA Option 122, 80 MHz BW Digitizing Hardware, and PSA Option 140, 40 MHz Digitizing Hardware, including detailed function descriptions, SCPI commands, and concepts, see the *PSA Basic Mode Guide*.

Modulation Analysis Measurements in 8 Steps

NOTE PSA Option 241 can analyze digital modulation for a single code channel only. If multiple code channels are transmitted, synchronization will fail, and incorrect EVM results will be obtained. For modulation quality measurements of multiple code channels, Modulation Accuracy and Code Domain measurements must be performed by a full-featured standard-based personality, like PSA Option BAF for W-CDMA.

Step 1. Select the modulation analysis personality from the mode menu:

Press **MODE, Digital Modulation**.

Step 2. Select the radio standard and device of your signal (if known):

Press **Mode Setup, Radio, Radio Standard**, then select a radio format. Press **Device**, then select **BTS** or **MS**.

Selecting a radio standard will preset the **Meas Setup** modulation parameters to demodulate a standard radio signal.

Step 3. Activate the modulation analysis measurement:

Press **MEASURE, Modulation Analysis**.

When you select **Modulation Analysis**, the PSA demodulates the radio standard, selected in Step 2, based off of the preset modulation parameters. If your signal has modulation properties that differ from the preset radio standards, follow steps 4 through 7 to modify the modulation parameters.

Step 4. Select a modulation format:

Press **Meas Setup, Demod, Modulation Format**, then select the modulation format of your signal from the available selections.

TIP If you do not know the modulation format of your signal, identifying an unknown signal format is a significant challenge requiring specialized expertise. For more information on this subject see, [“Modulation Formats and Applications” on page 203](#).

Step 5. Set the symbol rate of your signal:

Press **Meas Setup, Demod, Symbol Rate**, then use the front-panel keypad to input a numerical rate, then press a units key, like **kHz**, to complete the entry.

Step 6. Select the measurement filter type, the reference filter type and the filter roll-off (alpha) value:

Press **Meas Setup, Demod, Meas Filter**, then select a filter type.
Press **Meas Setup, Demod, Ref Filter**, then select a filter type.
Press **Meas Setup, Demod, Alpha/BT**, then enter a numeric value.

When selecting the filter types, remember: the “measured” filter should simulate the intended receiver, while the “reference” filter should match the product of the transmitter and receiver filters.

TIP If the alpha/BT is unknown, you can make a starting estimate based on the signal bandwidths as follows: $(-60 \text{ dB BW} / -3 \text{ dB BW}) - 1$.

EVM peaks between symbols mean an incorrect alpha, but won't usually affect the EVM% readout (except in GSM). In the worst case, start with an alpha of 0.3 and manually adjust up or down for lowest intersymbol peaks.

Step 7. Select the measurement interval and the number of data points per symbol for the measurement:

Press **Meas Setup, Demod, Meas Interval**, then use the front-panel keypad to input an interval in symbols, and press **Enter** to complete the entry.

Press **Display, Pts/Symbol**, then select **1, 2, 4, 5, or 10** points per symbol.

More points/symbol reveal more detail of the intersymbol waveforms (for viewing eye diagrams, error peaks, etc.). The drawback of demodulating using more points/symbol is a slower measurement.

TIP Result length is important for burst signals, as you do not want to include data symbols taken before or after the burst (that is, you do not want to demodulate noise). See Concepts chapter for [“PSA Digital Demodulator” on page 281](#).

Step 8. Turn on Burst/Sync search for burst signals:

Press **Meas Setup, Burst Sync/Search, Sync**, then select a sync method.

Other burst search settings include **Burst Search Threshold, Search Length, Sync Pattern, Sync Word Length** and **Sync Offset**.

TIP Maximum search length can be many times longer than a measurement length; set the search length to the burst “off” time plus twice the burst “on” time to insure that a complete burst will always be captured.

NOTE The settings described in steps 5 through 8 are also available in a single location. Press **Meas Setup, Meas Setup...** to see all the measurement settings.

Modulation Analysis Measurement Final Checks

- The EVM% result should be fairly consistent from measurement to measurement. Result peaks may indicate faulty triggering or incorrect synchronization.
- EVM vs. symbol trace should be noise-like, but fairly uniform (short peaks are OK). Abrupt changes within the EVM trace signify problems, as do sloping or V-shaped distributions.
- Overall shape of eye and constellation diagrams are regular and stable (even if individual symbols are very noisy, the characteristic shape should be evident). Eye opening should line up precisely with the display center line—if not, tweak “clock adjust” for best centering (lowest EVM). See [“Setting Advanced Measurement Setup Properties” on page 59](#) for more information on setting clock adjust.
- If measurement results are variable, and you suspect low signal-to-noise ratio is reducing your measurement accuracy, turn on the analyzer internal preamplifier:

Press **Input/Output, More (1 of 2), Int Preamp (On)**.

- You may also be able to optimize the dynamic range of the measurement by setting the RF input range as low as possible without overload:

Press **Meas Setup, More, Advanced, ADC Range, Manual** then select the highest ADC gain value that may be used without tripping the **Input Overload** annunciator (at the lower edge of the spectrum display screen).

Check: Increase ADC gain by 1 step; overload indicators should turn on. Finer adjustments can be made by setting the internal RF attenuation: you want to find the lowest ADC gain value that just trips the **Input Overload** annunciator. Use one 2 dB attenuator step lower than the attenuator setting that set the analyzer in overload.

Press **Input/Output, Input Atten** and select the lowest attenuation value that can be used without tripping the **Input Overload** annunciator.

- If these methods do not improve the “noisy” characteristics of your measurement, you may need to supply more signal gain ahead of the RF input to the analyzer. Make sure you use the analyzer’s ability to correct for external gain and attenuation:

Press **Input/Output, Ext RF Atten** and select either **BTS** or **MS**. You may enter a positive number to correct for external attenuation or input a negative number to correct the power measurements for external gain.

NOTE

When tuned above 3GHz, the PSA employs a YIG-tuned preselector filter. This filter is required for full image protection, but it may be bypassed if Option 123 Unpreselected High Band hardware is installed. This option is especially useful when measuring band-limited signals in the absence of any other signals. If the Microwave Preselector is bypassed (OFF), then the IF frequency response at a given center frequency is repeatable. See [“Microwave Preselector” on page 127](#).

Modifying Measurement Setup Parameters

Using the Measurement Setup Form

The measurement setup form contains demodulation parameters, averaging, triggering, burst/sync search parameters and equalization parameters. It is useful for a quick overview of all the key measurement settings without having to access each menu map individually to check or modify settings.

This procedure demonstrates how to navigate and modify settings in the measurement setup form. This procedure assumes you are already in the **Digital Modulation** mode and you have selected **Modulation Analysis** under the **MEASURE** menu.

Step 1. Access the measurement setup form:

Press **Meas Setup, Meas Setup...**

Step 2. Navigate through the measurement setup settings:

Press → (right tab arrow), or ← (left tab arrow).

To modify the current settings, navigate to the parameter you want to modify with the left or right arrow keys. If the input box is highlighted in blue, you can use the soft key menu on the right of the display to select your setting. If the input box is highlighted in yellow, use the numeric keypad to enter a value and then select a unit key from the soft key menu.

Figure 2-14 Measurement Setup Form with Preset Values (Radio=W-CDMA)

Agilent Digital Modulation	
Ch Freq 1.00000 GHz	IF: Wide Completed
Modulation Analysis QPSK	Averages: 10
Modulation Format QPSK	
Modulation Format QPSK	Average On
Meas Filter Root Nyquist	Avg Number 10
Ref Filter Nyquist	Average Mode Repeat
Alpha/BT 0.22	Trace Avg Type RMS
Symbol Rate 3.840000 MHz	FFT Window Type Flat Top
Meas Interval 256 symbols	Trig Source Free Run
IF Band Width 15.36 MHz	Carrier Lock Normal
IF Band Width Mode Auto	Sync None
EQ Filter Off	Burst Search Th. -20.00 dB
EQ Filter Length 5	Search Length 10.000000 ms
EQ Convergence 1.000000	Sync Word Length 10 symbols
EQ Hold Off	Sync Offset 0 symbols
Sync Ptrn 0000	

If you are using a preset radio standard, the measurement settings are preset for your measurement. Modify the settings to match your modulation parameters or testing requirements.

Setting Demodulation Parameters

To demodulate customized digital formats, the demodulation parameters can be modified. Choose from a wide range of basic digital formats, measurement and reference filters, filter alpha/BT values and symbol rates. By modifying demodulation parameters to improve EVM, you can estimate what needs to be changed in your device under test to meet your test specifications.

The following procedure demonstrates how to modify demodulation parameters. This procedure assumes you are already in the **Digital Modulation** mode and you have selected **Modulation Analysis** under the **MEASURE** menu.

Step 1. Access the demodulation menu:

Press **Meas Setup, Demod.**

Step 2. Select a modulation format:

Press **Modulation Format**, then select a format.

Modulation formats include BPSK, QPSK, 8PSK, DQPSK, D8PSK, Pi/4 DQPSK, Offset QPSK, 16QAM, 32QAM, 64QAM, 128QAM, 256QAM, EDGE, 2FSK, 4FSK, 8FSK, MSK type1 and type2, DVB QAM 16, 32, 64, 128, and 256.

Step 3. Select a measurement filter type:

Press **Meas Filter**, then select a filter type.

Filter types include root nyquist, nyquist, gaussian, EDGE measured filter (EMF), CDMA (IS-95 Base EQ), rectangle, and no filter.

Step 4. Select a reference filter type:

Press **Ref Filter**, then select a filter type.

Filter types include root nyquist, nyquist, gaussian, EDGE and CDMA (IS-95 Base), rectangle, and half sine.

When selecting the filter types, remember: the “measured” filter should simulate the intended receiver, while the “reference” filter should match the product of the transmitter and receiver filters.

Step 5. Enter a filter alpha/BT value:

Press **Alpha/BT**, enter a numeric value, then press **Enter**.

Step 6. Enter a symbol rate:

Press **Symbol Rate**, enter a numeric value, then select a unit.

Setting up a Trigger Source

For burst signals and TDMA (time division multiple access) signals, it is necessary to use a trigger for RF and modulation analysis of the signal.

For more detailed information on trigger types see “[Measurement Domains](#)” on page 279.

This procedure reviews the available trigger source types. This procedure assumes you are already in the **Digital Modulation** mode and you have selected **Modulation Analysis** under the **MEASURE** menu.

Step 1. Access the trigger source menu:

Press **Meas Setup, Trigger Source**.

Step 2. Select a trigger source from the list:

- **Free Run (Immediate)** - Sets the trigger to start a new sweep/measurement as soon as the last one has ended (continuous sweep mode) or immediately (single sweep mode). Free run trigger is completely asynchronous to the RF or IF signal.
- **Video (IF Envelope)** - Activates the trigger condition that allows the next sweep to start if the detected RF envelope voltage crosses a level set by the video trigger level.
- **RF Burst (Wideband)** - An internal wideband RF burst trigger that has an automatic level control for burst signals. It triggers on a level that is relative to the peak of the signal passed by the RF.
- **Ext Front** - Sets the trigger to start a new sweep/measurement whenever the external voltage (connected to **EXT TRIGGER INPUT** on the front panel) passes through approximately 1.5 volts.
- **Ext Rear** - Sets the trigger to start a new sweep/measurement whenever the external voltage (connected to **TRIGGER IN** on the rear panel) passes through approximately 1.5 volts.
- **Frame** - Sets the trigger to use the internal frame clock to generate a trigger signal. The clock parameters are controlled in the Trig Setup menu (under the Mode Setup key).

Setting Burst/Sync Properties

Synchronization words (or patterns) are often used to resolve carrier phase ambiguity on non-differential modulation formats. It is important to realize that synchronization words are optional and are not necessary to achieve carrier locking.

Sync search lets you use a synchronization pattern to isolate a segment of your signal for display and analysis. The analyzer searches through demodulated data to find your synchronization pattern and then uses the **Sync Word Length** to determine how many symbols to search as the syncword.

Triggering is used to determine when the analyzer starts searching syncword or burst in data and **Search Length** determines when the analyzer stops searching.

Searching more detailed information on synchronization see [“PSA Digital Demodulator” on page 281](#).

This procedure demonstrates how to set burst/sync properties. This procedure assumes you are already in the **Digital Modulation** mode and you have selected **Modulation Analysis** under the **MEASURE** menu.

Step 1. Access the synchronization menu:

Press **Meas Setup, Burst/Sync Search**.

Step 2. Select the synchronization type:

Press **Sync**, then chose from one of the available sync types.

Available synchronization types include **RF Ampl**, **Sync Word Cont**, **Sync Word Burst** and you have the option of selecting no sync type (**None**).

Step 3. Set the burst search threshold level for RF amplitude and sync word burst synchronization types:

Press **Burst Search Threshold**, enter a numeric value, then press **dB**.

Once the trigger requirements have been met and **RF Ampl** or **Sync Word Burst** is selected as a sync type, the burst must meet the threshold level before the sync search starts. If the threshold level is met, the analyzer will demodulate the burst for the time period set in **Search Length**.

Step 4. Set the length of time you want to search the burst or the synchronization pattern:

Press **Search Length**, enter a numeric value, then select a unit, like **ms**.

Your trigger signal determines when the analyzer begins accumulating data for the search length. The analyzer begins to demodulate your signal when it receives a valid trigger, and capture data for the duration

of **Search Length**.

Step 5. Set the synchronization bit pattern in hexadecimal values:

Press **Sync Pattern**, enter a bit pattern as hexadecimal values, then press **Done**

The synchronization pattern is used when **Sync Word Cont** or **Sync Word Burst** is enabled as a sync search type. **Sync Pattern** is not used when **RF Ampl** sync search type is enabled.

Step 6. Set the length of the synchronization word length:

Press **Sync Word Length**, enter a numeric value, then press **Enter**.

Sync Word Length determines how many symbols are used as SyncWord. See “[Sync Word Length](#)” on page 161 for word length settings. The Synchronization word length is used when **Sync Word Cont** or **Sync Word Burst** is enabled as a sync search type.

Step 7. Set the synchronization offset:

Press **Sync Offset**, enter a numeric value, then press **Enter**.

Synchronization offset can be set from –1000 to 1000 symbols as described in “[Sync Offset](#)” on page 161. Synchronization offset determines the relative position of the measured data from the beginning of the SyncWord; with respect to the start of the sync pattern. Synchronization offset is used when **Sync Word Cont** or **Sync Word Burst** is enabled as a sync search type.

Using Adaptive Equalization

Equalization removes linear errors from modulated signals by dynamically creating and applying a FIR (feed-forward) compensating filter. Using equalization allows measurement of impaired channels and can be used to isolate linear from non-linear error mechanisms. For more concept information on equalization see “[Modulation quality measurements](#)” on page 286.

This procedure demonstrates how to setup the equalizer. This procedure assumes you are already in the **Digital Modulation** mode and you have selected **Modulation Analysis** under the **MEASURE** menu.

Step 1. Access the equalization menu:

Press **Meas Setup, More, Equalization**.

Step 2. Set the equalization filter length:

Press **EQ Filter Length**, enter a numeric value, then press **Enter**.

Available filter length values include 3, 5, 7 and 99 symbols.

When selecting a filter length, the best filter length is the smallest that

meets your measurement requirements. For example, measurements at the transmitter may only need a few symbols in length. Measurements in multi-path environments require longer filter lengths.

Step 3. Set the equalization convergence:

Press **EQ Convergence**, enter a numeric value, then press **Enter**.

You can set convergence values from 0.001 to 100.

Convergence determines how quickly the equalization filter coefficients converge to the estimated values for each measurement. Larger values converge faster. Values set too large can cause the adaption algorithm to become unstable, limiting the minimum EVM or SNR.

TIP

At the start of your measurement set the convergence high, to quickly shape the filter. Then decrease the convergence to fine-tune the filter to the optimum shape to get the best EVM results.

Step 4. Turn the equalization filter on:

Press **EQ Filter (On)**.

When equalization is first enabled, the equalization filter has a unit impulse response. The length of the filter determines the position of the unit impulse response in the filter. The impulse is located in the center of the filter for short filter lengths. As the filter length increases, the impulse moves, proportionally, towards the start of the filter to handle channels with large delay-spread.

The equalization filter has a unit response when you:

- First run the equalizer.
- Reset the equalizer filter
- Change points/symbol
- Change the measured or reference filter
- Change the symbol rate
- Change the clock delay adjustment
- Change the equalizer filter length
- Change the modulation format
- Preset the mode

Aside from the above conditions, the equalizer uses the last computed filter coefficients when you enable equalization. For example, if you used equalization in a previous measurement, the coefficients from the previous measurement are used, unless you reset the equalization filter (or change one of the settings as mentioned in the above list). It is good

practice to reset the equalization filter to initialize the filter coefficients before starting the measurement.

Step 5. Reset the equalization filter:

Press **Reset EQ Filter**. Once you reach the desired EVM results after resetting the equalization filter, hold the filter coefficient values.

Step 6. Hold the filter coefficient values:

Press **EQ Hold (On)**. When **EQ Hold** is on, the analyzer does not update the filter coefficients. Instead, the analyzer uses the last updated coefficients before selecting hold.

When **EQ Hold** is off, the analyzer uses the results of the current measurement to update the filter coefficients for the next measurement. The equalization algorithm chooses coefficients that produce a modulation quality result that is less impacted by the presence of linear distortion.

Step 7. You can view the equalizer graphically:

Press **Trace/View, Equalizer (Quad View)**. The Ch Frequency Response trace shows the frequency response channel for which the equalizer is correcting. Ch Frequency Response is computed as the inverse of the equalization filter's frequency response. The data is complex and is normally displayed in units of magnitude and phase.

The Eq Impulse Response trace shows the impulse response of the equalization filter. The example shown in [Figure 2-15](#) is an EDGE signal.

Figure 2-15

Equalizer View - EDGE Signal Example

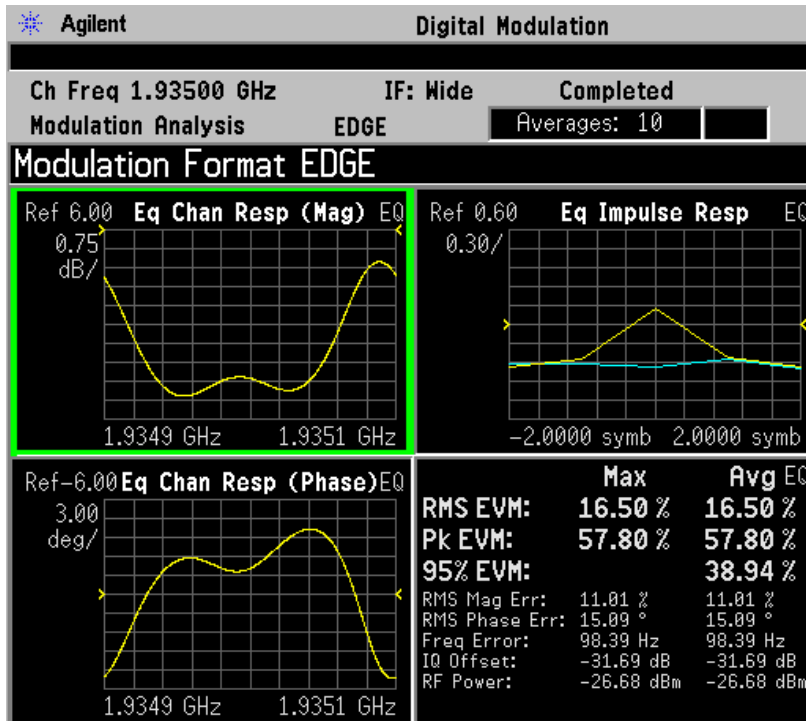

Setting Advanced Measurement Setup Properties

Advanced measurement features give you additional flexibility in setting measurement limits, adjusting the clock, setting the IF bandwidth and setting the analyzer ADC range.

This procedure demonstrates how to set advanced measurement properties. You can jump from step 1 to any other step in this procedure if you need to access a certain advanced setting. This procedure assumes you are already in the **Digital Modulation** mode and you have selected **Modulation Analysis** under the **MEASURE** menu.

Step 1. Access the advanced measurement menu:

Press **Meas Setup, More, Advanced**.

Step 2. Modify the pass/fail limit for RMS EVM:

Press **Limits, RMS EVM**, enter a numeric value, then press **%**.

When you enter a numeric value the limit turns on automatically. To toggle the limit off and on press **RMS EVM**.

Step 3. Modify the pass/fail limit for frequency error:

Press **Limits, Freq Error**, enter a numeric value, then select a unit terminator, like **kHz**.

When you enter a numeric value the limit turns on automatically. To

toggle the limit off and on press **Freq Error**.

- Step 4.** Mirror (invert) the frequency spectrum about the analyzer center frequency for correct demodulation:

Press **Spectrum** (Invert).

By pressing **Spectrum** you can toggle the frequency spectrum between normal and inverted. The default spectrum setting is Normal.

Often, when a signal is mixed down from a higher frequency, the spectrum is flipped or mirrored about the center frequency as a result of the mixing scheme used. A mirror spectrum occurs when the frequency of the mixer's LO is higher than the frequency of the signal being measured.

- Step 5.** Modify clock adjust (in symbols) to determine when the demodulator samples the I/Q trajectory:

Press **Clock Adjust**, enter a numeric value, then press **Enter**.

Clock adjust can be set from -0.5 to $+0.5$ symbols. Zero (0) symbols is the default value.

Some digital communications systems contain non-linearity's that can bias the digital demodulator's estimation of the symbol clock position. Use clock adjust to compensate for this offset and obtain a lower EVM.

You can see the effects of changing clock adjust by displaying a constellation diagram or eye diagram. Increasing (or decreasing) clock adjust:

- Shifts the detection-decision points in the constellation diagram.
- Slides the eye diagram right or left (remember that in the eye diagram, the symbol locations remain in a fixed location on the display; therefore, changing the location of symbols has the effect of horizontally shifting of the eye diagram).

Step 6. Toggle the EVM reference calculation between mean and max:

Press **EVM Ref Calc**.

The EVM reference calculation is available when demodulating one of the QAM formats. When **EVM Ref Calc** is set to mean, the mean magnitude of all QAM decision points are used as the reference. When it is set to max, the magnitude of the decision points with the largest distance from the origin are used as a reference.

Step 7. Modify the IF bandwidth setting:

Press **IF Bandwidth** (Man), enter a numeric value, then select a unit key, like **MHz**. For the optimum EVM accuracy, IF Bandwidth should encompass all the significant power spectral density of the channel.

If installed, PSA Option 122, 80 MHz Bandwidth Digitizer hardware may be used to capture up to 80 MHz of signal spectrum. Press **Meas Setup, More, IF Path**, and toggle the setting to **Wide** to increase the available IF bandwidth of the instrument. See [“Wideband Setup” on page 171](#) for more details of using the wideband IF path.

The default state is set to auto. If no radio standard is selected, the default setting is 10 MHz. The maximum setting is 10 MHz and the minimum setting is 1 kHz.

When the **IF Bandwidth** is set to auto, the IF bandwidth is determined based on the radio standard format and symbol rate ($IF\ Bandwidth = symbol\ rate \times 4$).

Step 8. Select an ADC ranging method:

Press **ADC Range**, then select an ADC range type.

The **ADC Range** default is set to Auto. You can select from **Auto**, **Auto Peak**, **AutoPeakLock** and **Manual**:

- **Auto** - Select this to set the ADC range automatically.
- **Auto Peak** - Select this to set the ADC range automatically to the peak signal level. Auto peak is a compromise that works well for both CW and burst signals.
- **AutoPeakLock** - Select this to hold the ADC range to the peak signal level.
- **Manual** - Select from one of the following ADC range levels: **0 dB**, **+6 dB**, **+12 dB**, **+18 dB** or **None**. Select **None** to lock the range at the present value. Manual range settings provides the best measurement results for CW signals.

Measuring Digital Modulation Formats

Modulation Analysis Measurement Views

To help pin-point modulation problems, the modulation analysis personality provides I/Q polar graphs, EVM versus time graphs, eye diagrams and numeric results tables. The following procedures show you how to navigate through the results displays using a W-CDMA signal (Bluetooth is used for the FSK displays).

- [“Setting up the Modulation Analysis Personality” on page 63](#)
- [“Viewing the I/Q Polar Vector and Constellation Graphs” on page 64](#)
- [“Viewing the Numeric Measurement Results” on page 66](#)
- [“Viewing the I/Q Error \(Quad-View\) Results” on page 67](#)
- [“Viewing the Magnitude Error Versus Time Results” on page 68](#)
- [“Viewing the Phase Error Versus Time Results” on page 70](#)
- [“Viewing the EVM Versus Time Results” on page 73](#)
- [“Viewing the Eye Diagram Results” on page 75](#)
- [“Viewing the FSK Error \(Quad-View\) Results” on page 77](#)
- [“Viewing the FSK Error Versus Time Results” on page 79](#)
- [“Viewing the FSK Error Spectrum Results” on page 81](#)
- [“Viewing the FSK Measured Time Results” on page 83](#)

Modulation Analysis Examples

The following examples analyze industry standard wireless communication signals for each family of the basic digital modulation formats.

- [“PSK Modulation Analysis \(cdma2000 QPSK Example\)” on page 85](#)
- [“QAM Modulation Analysis \(64QAM Example\)” on page 87](#)
- [“EDGE Modulation Analysis” on page 89](#)
- [“FSK Modulation Analysis \(Bluetooth 2FSK Example\)” on page 91](#)
- [“MSK Modulation Analysis \(GSM MSK type 1 Example\)” on page 93](#)

For a list of all available basic digital formats and pre-set radio standard formats see [“Digital Modulation Format Standards” on page 203](#).

Setting up the Modulation Analysis Personality

This procedure is the first step toward making any measurements with the modulation analysis personality.

Configuring the Measurement System

Refer to [“Configuring a BTS Measurement System” on page 29](#) to connect the measurement equipment.

Agilent ESG Series Vector Signal Generator Settings

Radio Standard: W-CDMA (3GPP)
Link: Forward
Active channel: 1 DPCH (data channel)
Frequency: 1 GHz
Power (Signal Amplitude): -20 dBm
Modulation: QPSK
Filter: WCDMA, 0.22 alpha
Symbol rate: 3.84 Msps

Measurement Procedure

If you have a problem, and get an error message, see [“Interpreting Error Codes” on page 119](#).

Step 1. Preset the instrument and select the digital modulation personality:

Press **Preset, Factory Preset** (if available).
Press **MODE, Digital Modulation**.

Step 2. Select the W-CDMA pre-set radio standard and base station device:

Press **Mode Setup, Radio, Radio Standard, WCDMA**.
Press **Device (BTS)**, to underline BTS.

Step 3. Set the center frequency to 1 GHz.

Press **FREQUENCY Channel, Center Freq, 1, GHz**.

Step 4. Enable the modulation analysis mode to measure and display EVM and other modulation metrics.

Press **MEASURE, Modulation Analysis**.

The default view for the modulation analysis personality is the I/Q Measured Polar Vector graph (see [Figure 2-16](#)).

Viewing the I/Q Polar Vector and Constellation Graphs

This procedure demonstrates the different views of the I/Q measured polar graphs. The I/Q polar graphs can show symbol point trajectories (inter-symbol data) and constellation points at the same time or individually. A common example of viewing the vector (inter-symbol) data is to determine if the filter roll-off value (alpha) is set too steep or shallow as shown by the length of the trajectory past the symbol point.

Measurement Procedure

If you have a problem, and get an error message, see “[Interpreting Error Codes](#)” on page 119.

- Step 1.** Follow the procedure “[Setting up the Modulation Analysis Personality](#)” on page 63 before continuing.
- Step 2.** View the I/Q measured polar graph with vector data and constellation points (this is the default view):

Press **Trace/View, I/Q Measured Polar Graph**.

The default view for the modulation analysis personality is the I/Q Measured Polar Vector graph (see [Figure 2-16](#)). The measurement values for EVM, magnitude error, phase error, frequency error, I/Q offset and rho are shown in the summary window on the left side of the display.

Figure 2-16 I/Q Measured Polar Vector Graph (Default View)

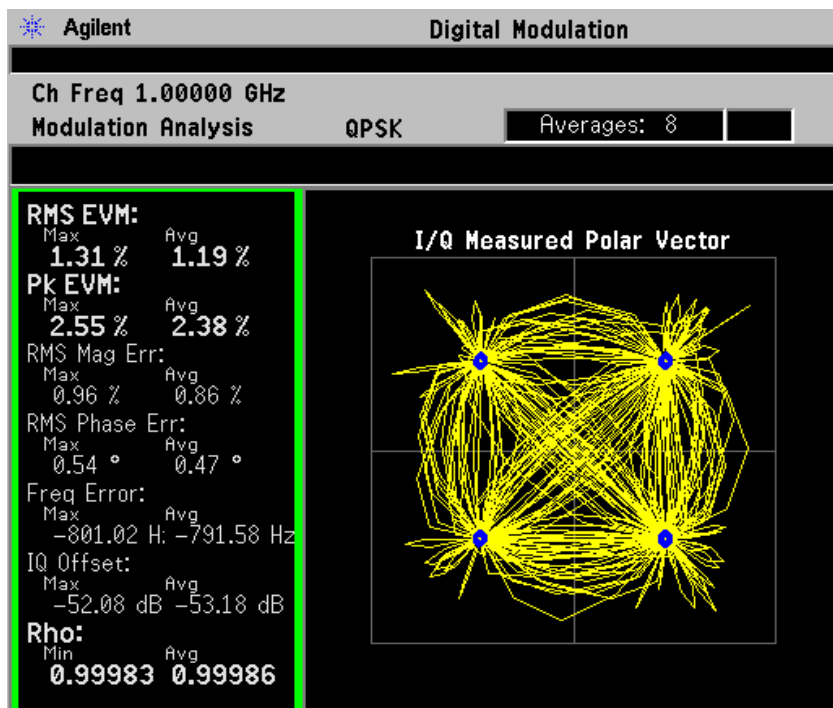

Step 3. View the I/Q measured polar graph with vector (inter-symbol data) or constellation points only. Press **Display**, **I/Q Polar Type**, **Vector** to see Vector data (Figure 2-17). Press **Display**, **I/Q Polar Type**, **Constellation** to see Constellation data (Figure 2-18).

Figure 2-17 I/Q Measured Polar Graph - Polar Vector View

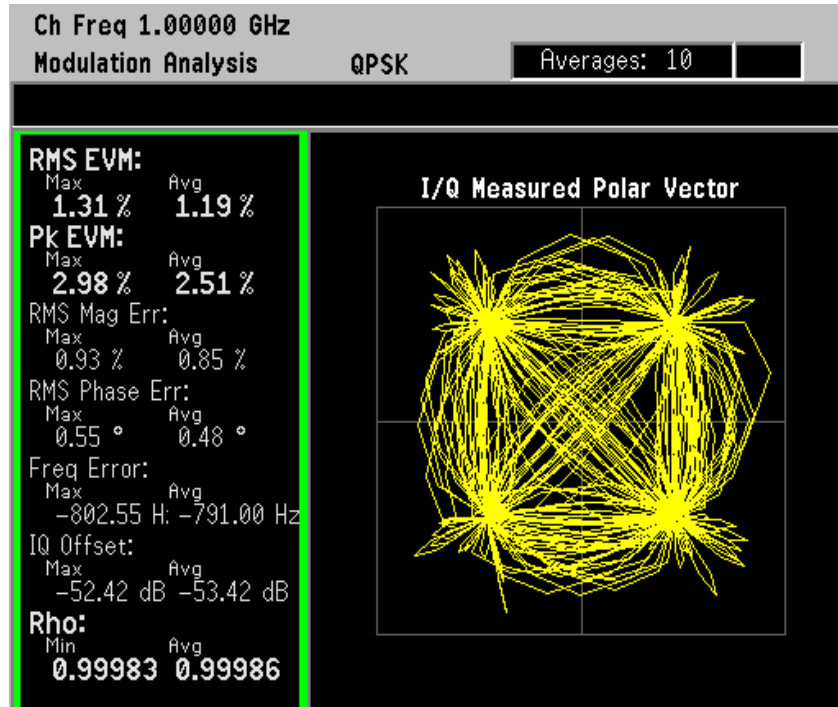
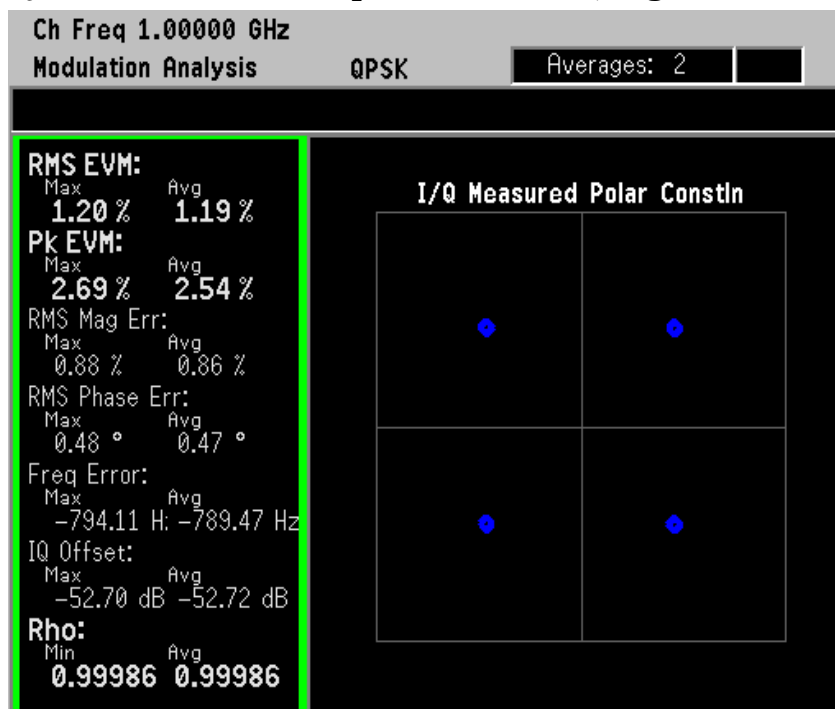

Figure 2-18 I/Q Measured Polar Graph (Left - Vector, Right - Constellation)



Viewing the Numeric Measurement Results

The numeric results provide you with the most important modulation results to determine where the problem might lie. It's a good starting point to compare results side-by-side and decide which measurement view to go to next.

Measurement Procedure

If you have a problem, and get an error message, see [“Interpreting Error Codes” on page 119](#).

Step 1. Follow the procedure [“Setting up the Modulation Analysis Personality” on page 63](#) before continuing

Step 2. Select the numeric results view:

Press **Trace/View, Numeric Results**.

Figure 2-19 Numeric Results View (QPSK Example)

Agilent		Digital Modulation	
Ch Freq 1.00000 GHz			
Modulation Analysis		QPSK	Averages: 2
	Max	Avg	
RMS EVM	1.37 %	1.32 %	
Peak EVM	2.80 % at sym 121	2.65 % at sym 121	
RMS Mag Error	1.00 %	0.96 %	
Peak Mag Error	-2.48 % at sym 22	-0.09 % at sym 252	
RMS Phase Error	0.54 °	0.52 °	
Peak Phase Error	-1.54 ° at sym 121	-1.42 ° at sym 121	
Frequency Error	-791.19 Hz	-789.83 Hz	
IQ Offset	-52.68 dB	-52.70 dB	
Quadrature Skew	0.00 °	0.02 °	
IQ Gain Imbalance	0.02 dB	0.01 dB	
SNR(MER)	Min 36.05 dB	36.41 dB	
Rho	Min 0.99981	0.99983	

The numeric results summary table shows modulation data including maximum and average values for EVM, magnitude error, phase error, frequency error, I/Q offset, quadrature skew, I/Q gain imbalance, SNR and Rho.

NOTE

The numeric result types differ between modulation formats. For example, FSK results don't provide phase results. See [“FSK Modulation Analysis \(Bluetooth 2FSK Example\)” on page 91](#) for more information.

Viewing the I/Q Error (Quad-View) Results

This procedure demonstrates the different views of the I/Q error quad-view. The I/Q error quad-view allows you to see the magnitude error versus time, phase error versus time, EVM versus time and a numeric summary table all on one screen to quickly determine any impairments that may exist. You can zoom in on each of the 4 views for more resolution to help pin-point any problems.

If you have a problem, and get an error message, see “[Interpreting Error Codes](#)” on page 119.

Step 1. Follow the procedure “[Setting up the Modulation Analysis Personality](#)” on page 63 before continuing.

Step 2. View the I/Q error quad-view:

Press **Trace/View, I/Q Error (Quad-View)**.

Figure 2-20 I/Q Error (Quad-View)

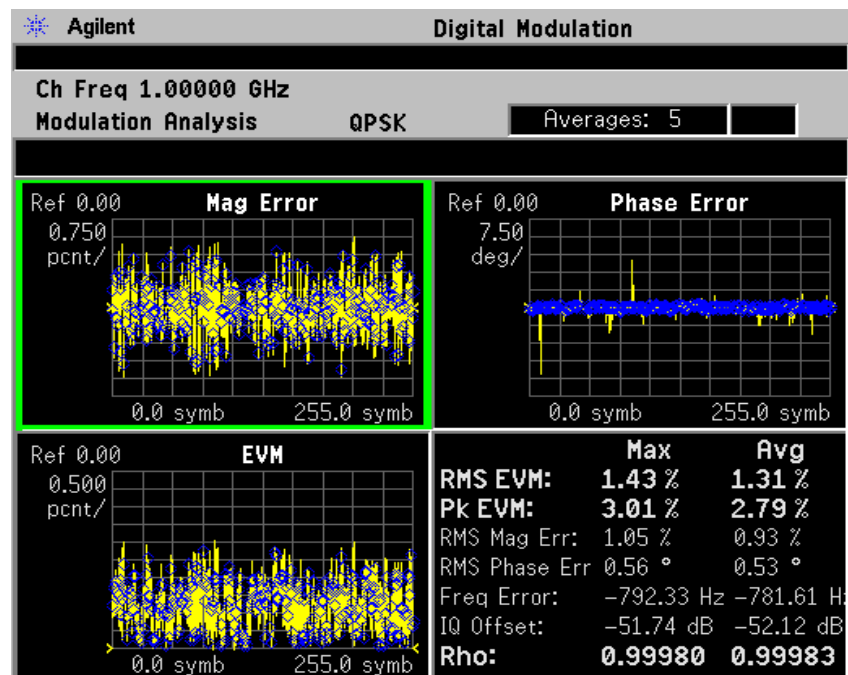

The I/Q error quad-view measurement result displays three graphs and one numeric results summary table. The graphs consist of Mag Error versus symbol, Phase Error versus symbol and EVM versus symbol. The numerical results table shows key modulation metrics as maximum and average values associated with the last demodulated capture period.

NOTE

Using the **Next Window** key, you can scroll through the measurement displays, where the current selection is highlighted with a green box outline. The **Zoom** key will zoom in on the currently selected display. To go back to the quad-view display press **Zoom** again.

Viewing the Magnitude Error Versus Time Results

This procedure shows you how to adjust x-axis and y-axis settings for the magnitude error versus time graph. By zooming into a time capture area of interest, modulation magnitude errors can be identified easier.

If you have a problem, and get an error message, see “[Interpreting Error Codes](#)” on page 119.

Step 1. Follow the procedure “[Setting up the Modulation Analysis Personality](#)” on page 63 before continuing.

Step 2. View the I/Q error quad-view (see [Figure 2-20](#)):

Press **Trace/View, I/Q Error (Quad-View)**.

Step 3. View the zoomed-in graph of magnitude error versus symbol. Use markers to look at the magnitude error of individual symbol points.

Press **Zoom**.

Press **Marker, Trace, Mag Error**.

NOTE

Using the **Next Window** key, you can scroll through the measurement displays, where the current selection is highlighted with a green box outline. The **Zoom** key will zoom in on the currently selected display. To go back to the quad-view display press **Zoom** again.

Figure 2-21 I/Q Error: Magnitude Error versus Symbol

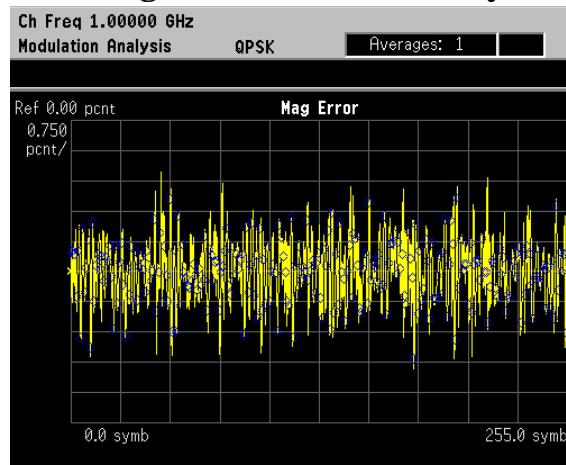

The Mag Error measurement display shows the magnitude error versus symbol. Depending on the number of symbols captured in the Meas Interval key, by measurement default parameters, the x-axis displays symbols 0 through 1 minus the Meas Interval

Step 4. Change the x-axis settings to zoom in on smaller portion of the measurement capture interval:

Press **SPAN X Scale, Scale/Div, 3, Symbols.**

To place the symbol points on the vertical graticules, use integer symbol values for **Scale/Div**. An alternate method to view less symbols is to reduce the measurement interval with the **Meas Interval** key. If you want to view another portion of the time capture interval, adjust the **Ref Value**.

Figure 2-22

I/Q Error: Magnitude Error versus Symbol (X-Axis Settings)

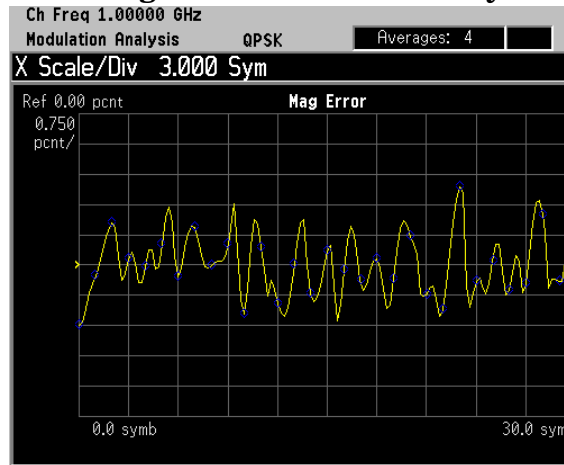

The Mag Error measurement displayed in **Figure 2-22** shows an x-axis **Scale/Div** of 3 with a measurement capture interval of 256 symbols.

Step 5. Decrease the y-axis settings to increase the resolution of the magnitude error results. Use the same x-axis settings from the previous step.

Press **AMPLITUDE Y Scale, Scale/Div, 0.4, %.**

Figure 2-23

I/Q Error: Magnitude Error versus Symbol (Y-Axis Settings)

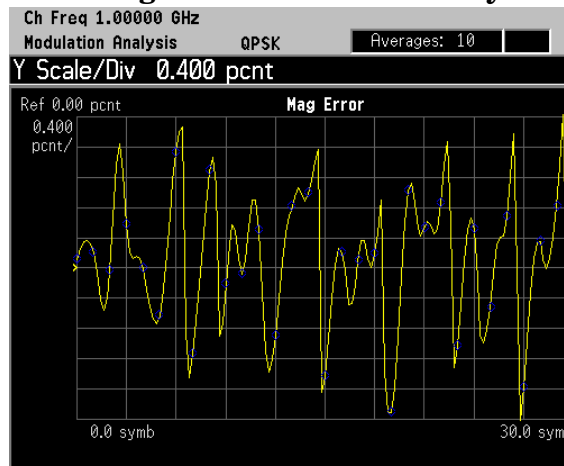

The Mag Error measurement displayed in **Figure 2-23** shows a y-axis **Scale/Div** of 0.4 percent and a reference level of 0 percent.

Viewing the Phase Error Versus Time Results

This procedure shows you how to adjust x-axis and y-axis settings for the phase error versus time graph. By zooming into a time capture area of interest, modulation phase errors can be identified easier.

If you have a problem, and get an error message, see “[Interpreting Error Codes](#)” on page 119.

Step 1. Follow the procedure “[Setting up the Modulation Analysis Personality](#)” on page 63 before continuing.

Step 2. View the I/Q error quad-view (see [Figure 2-20](#)):

Press **Trace/View, I/Q Error (Quad-View)**.

Step 3. View the zoomed in graph of phase error versus symbol. Use markers to look at the phase error of individual symbol points.

Press **Next Window** until the Phase Error window is selected.

Press **Zoom**.

Press **Marker, Trace, Phase Error**.

NOTE

Using the **Next Window** key, you can scroll through the measurement displays, where the current selection is highlighted with a green box outline. The **Zoom** key will zoom in on the currently selected display. To go back to the quad-view display press **Zoom** again.

Figure 2-24 I/Q Error: Phase Error versus Symbol

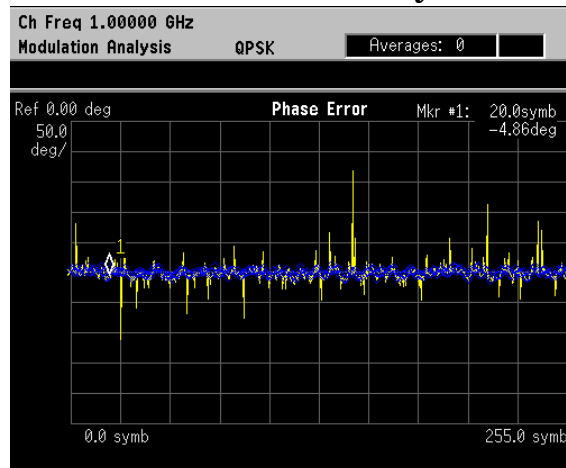

The Phase Error measurement display shows the phase error versus symbol. Depending on the number of symbols captured in the **Meas Interval** key, by measurement default parameters, the x-axis displays symbols 0 through 1 minus the **Meas Interval**

Step 4. Change the x-axis settings to zoom in on smaller portion of the measurement capture interval:

Press **SPAN X Scale, Scale/Div, 3, Symbols.**

To place the symbol points on the vertical graticules, use integer symbol values for **Scale/Div**. An alternate method to view less symbols is to reduce the measurement interval with the **Meas Interval** key. If you want to view another portion of the time capture interval, adjust the **Ref Value**.

Figure 2-25

I/Q Error: Phase Error versus Symbol (X-Axis Settings)

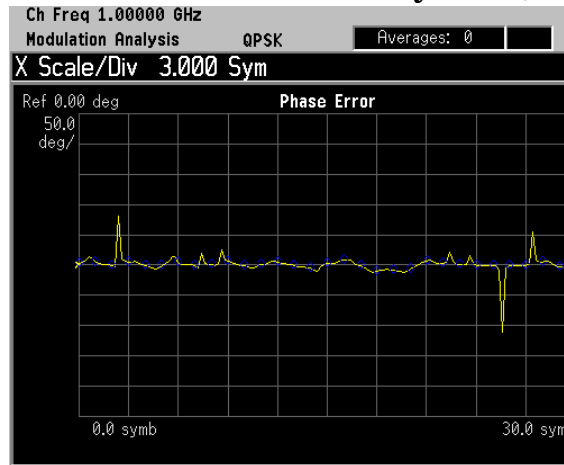

The Phase Error measurement displayed in [Figure 2-25](#) shows an x-axis **Scale/Div** of 3 with a measurement capture interval of 256 symbols.

Step 5. Decrease the y-axis settings to increase the resolution of the phase error results. Use the same x-axis settings from the previous step.

Press **AMPLITUDE Y Scale, Scale/Div, 20, Degrees.**

Figure 2-26

I/Q Error: Phase Error versus Symbol (Y-Axis Settings)

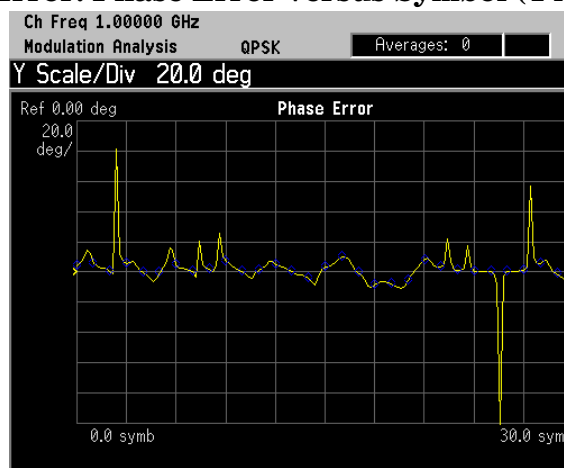

The Phase Error measurement displayed in [Figure 2-26](#) shows a y-axis

Making Measurements
Measuring Digital Modulation Formats

Scale/Div of 20 degrees and a reference level of 0 degrees.

Viewing the EVM Versus Time Results

This procedure shows you how to adjust x-axis and y-axis settings for the EVM versus time graph. By zooming into a time capture area of interest, EVM results can be analyzed at the symbol level.

If you have a problem, and get an error message, see “[Interpreting Error Codes](#)” on page 119.

Step 1. Follow the procedure “[Setting up the Modulation Analysis Personality](#)” on page 63 before continuing.

Step 2. View the I/Q error quad-view (see [Figure 2-20](#)):

Press **Trace/View, I/Q Error (Quad-View)**.

Step 3. View the zoomed in graph of EVM versus symbol. Use markers to look at the EVM of individual symbol points.

Press **Next Window** until the EVM window is selected.

Press **Zoom**.

Press **Marker, Trace, EVM**.

NOTE

Using the **Next Window** key, you can scroll through the measurement displays, where the current selection is highlighted with a green box outline. The **Zoom** key will zoom in on the currently selected display. To go back to the quad-view display press **Zoom** again.

Figure 2-27 I/Q Error: EVM versus Symbol

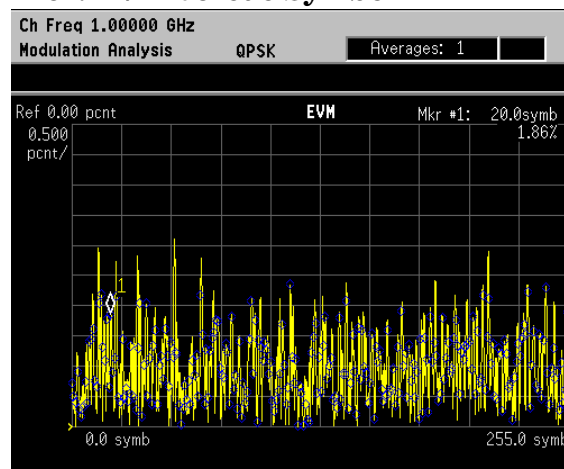

The EVM measurement display shows EVM versus symbol. Depending on the number of symbols captured in the **Meas Interval** key, by measurement default parameters, the x-axis displays symbols 0 through 1 minus the **Meas Interval**

Step 4. Change the x-axis settings to zoom in on smaller portion of the measurement capture interval:

Press **SPAN X Scale, Scale/Div, 3, Symbols.**

To place the symbol points on the vertical graticules, use integer symbol values for **Scale/Div**. An alternate method to view less symbols is to reduce the measurement interval with the **Meas Interval** key. If you want to view another portion of the time capture interval, adjust the **Ref Value**.

Figure 2-28

I/Q Error: EVM versus Symbol (X-Axis Settings)

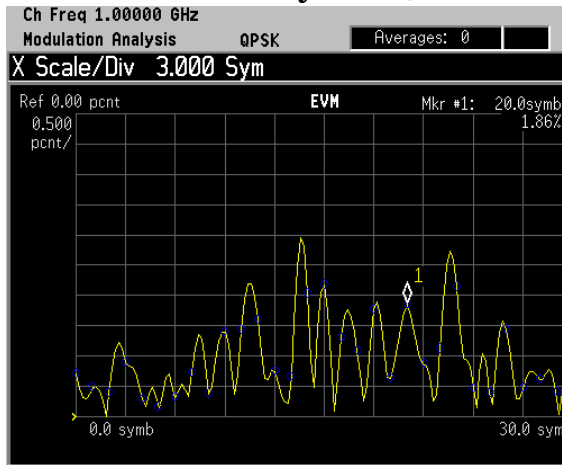

The EVM measurement displayed in [Figure 2-28](#) shows an x-axis **Scale/Div** of 3 with a measurement capture interval of 256 symbols.

Step 5. Decrease the y-axis settings to increase the resolution of the phase error results. Use the same x-axis settings from the previous step.

Press **AMPLITUDE Y Scale, Scale/Div, 0.3, %.**

Figure 2-29

I/Q Error: EVM versus Symbol (Y-Axis Settings)

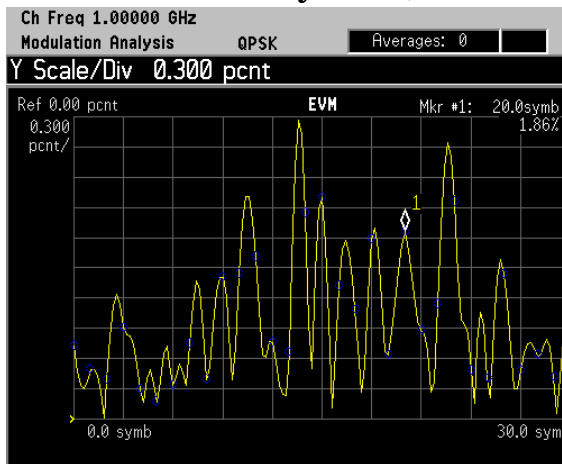

The EVM measurement displayed in [Figure 2-29](#) shows a y-axis **Scale/Div** of 0.3 percent and a reference level of 0 percent.

Viewing the Eye Diagram Results

This procedure demonstrates the different views of the eye quad-view. The eye quad-view allows you to view the eye I diagram, the eye Q diagram, I/Q measured polar vector graph and a numeric results summary table all on one screen to quickly determine any impairments that may exist. You can zoom in on each of the 4 views for more resolution to help pin-point any problems.

If you have a problem, and get an error message, see “[Interpreting Error Codes](#)” on page 119.

Step 1. Follow the procedure “[Setting up the Modulation Analysis Personality](#)” on page 63 before continuing.

Step 2. View the eye graphical results on a quad-view display.

Press **Trace/View, Eye (Quad-View)**.

Figure 2-30

Eye (Quad-View)

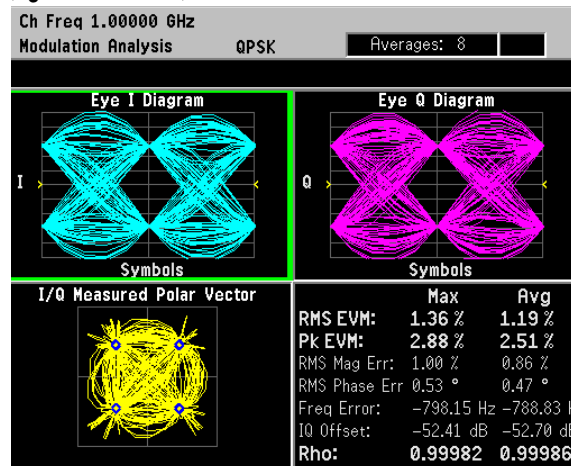

The eye quad-view measurement result displays two eye diagrams (I and Q). The I and Q eye diagrams show the transitions of constellation points of the QPSK signal. The eye diagrams are a continuous plot of the symbol transitions. The eye diagram has three symbol transitions, where the third symbol transition wraps around to the start of the eye diagram (first symbol point on the eye diagram).

Step 3. View the zoomed in eye I diagram. Make sure the green outline is highlighting the eye I diagram and zoom into the diagram.

Press **Zoom**.

NOTE

Using the **Next Window** key, you can scroll through the measurement displays, where the current selection is highlighted with a green box outline. The **Zoom** key will zoom in on the currently selected display. To go back to the quad-view display press **Zoom** again.

Figure 2-31 Eye I Diagram

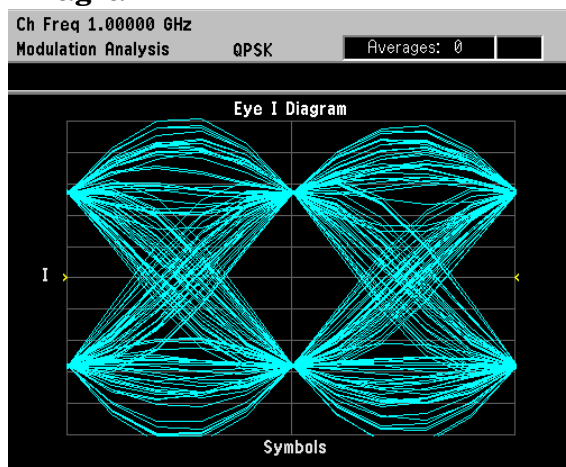

The Eye I Diagram shows the symbol transitions of the baseband I data. The Eye Q diagram is identical to the Eye I diagram except the symbol data from Q is offset 90 degrees from I.

Step 4. Change the scaling of the eye diagram:

Press **AMPLITUDE Y Scale, Scale/Div**.
Rotate front-panel knob clockwise to increase the scale/div value.

Step 5. Pause the measurement and build the eye diagram symbol-by-symbol:

Press **Meas Control, Pause**.
Press **Display, I/Q Points, 0, Enter**.
Rotate front-panel knob clockwise to add symbol points.

Figure 2-32 Eye I Diagram - Building Symbol-by-Symbol

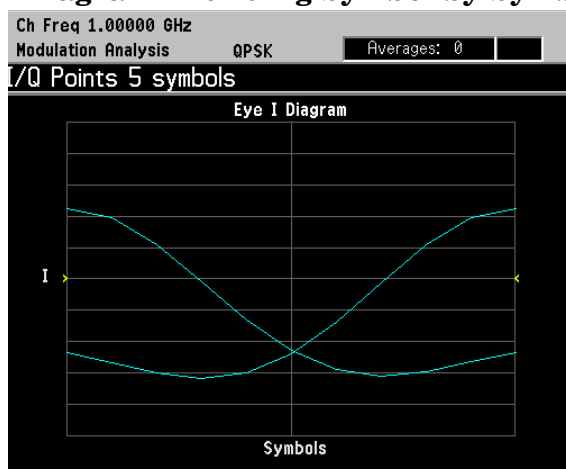

In Figure 2-32, the first 5 symbols are plotted, starting with symbol 1 on the far left-side of the diagram.

NOTE

The I/Q measured polar vector graph can be built the same way. Press **Meas Control, Resume** to continue.

Viewing the FSK Error (Quad-View) Results

This procedure demonstrates the FSK error quad-view display. The FSK error quad-view allows you to see the FSK error versus time, FSK error spectrum, FSK measured time and a numeric summary table all on one screen to quickly determine any impairments that may exist. You can zoom in on each of the 4 views for more resolution to help pin-point any problems.

NOTE

In this procedure, a bursted Bluetooth 2-level FSK signal is used with a symbol rate of 1 Msps, and a filter alpha of 0.5 at 1 GHz.

If you have a problem, and get an error message, see [“Interpreting Error Codes”](#) on page 119.

Step 1. Preset the instrument and select the digital modulation personality:

Press **Preset, Factory Preset** (if available).
Press **MODE, Digital Modulation**.

Step 2. Select the Bluetooth pre-set radio standard and base station device:

Press **Mode Setup, Radio, Radio Standard, More, Bluetooth**.
Press **Device (BTS)**, to underline BTS.

Step 3. Set the center frequency to 1 GHz.

Press **FREQUENCY Channel, Center Freq, 1, GHz**.

Step 4. Enable the modulation analysis mode to measure and display EVM and other modulation metrics.

Press **MEASURE, Modulation Analysis**.

Step 5. Set the trigger source to capture the burst:

Press **Meas Setup, Trig Source, RF Burst (Wideband)**.
Press **Meas Control, Restart**.

Figure 2-33

I/Q Measured Polar Graph

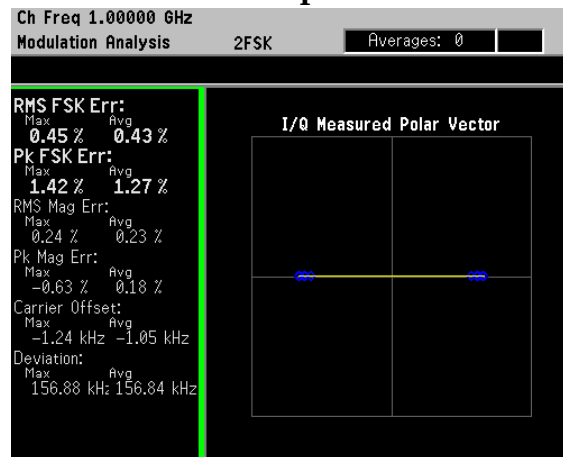

The default view for the modulation analysis personality is the I/Q Measured Polar Vector graph (see [Figure 2-33](#)).

Step 6. View the FSK error quad-view:

Press **Trace/View, FSK Error (Quad-View)**.

Figure 2-34 FSK Error (Quad-View)

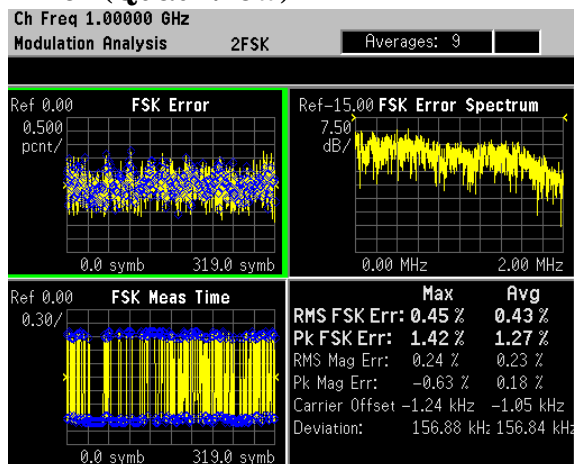

The FSK error quad-view measurement result displays three graphs and one numeric results summary table. The graphs consist of FSK Error versus symbol, FSK Error Spectrum and FSK Meas Time. The numerical results table shows key modulation metrics as maximum and average values associated with the last demodulated capture period.

NOTE

Using the **Next Window** key, you can scroll through the measurement displays, where the current selection is highlighted with a green box outline. The **Zoom** key will zoom in on the currently selected display. To go back to the quad-view display press **Zoom** again.

Viewing the FSK Error Versus Time Results

This procedure shows you how to adjust x-axis and y-axis settings for the FSK error versus time graph. By zooming into a time capture area of interest, the FSK error results can be analyzed at the symbol level.

NOTE In this procedure, a bursted Bluetooth 2-level FSK signal is used with a symbol rate of 1 Msps, and a filter alpha of 0.5 at 1 GHz.

If you have a problem, and get an error message, see “[Interpreting Error Codes](#)” on page 119.

Step 1. Follow steps 1 through 5 in the procedure “[Viewing the FSK Error \(Quad-View\) Results](#)” on page 77 before continuing.

Step 2. View the FSK error quad-view (see [Figure 2-34](#)):

Press **Trace/View, FSK Error (Quad-View)**.

Step 3. View the zoomed in graph of FSK error versus symbol. Use markers to look at the error of individual symbol points.

Press **Zoom**.

Press **Marker, Trace, FSK Error**. then use the numeric keypad or front-panel knob to place the marker on a symbol.

NOTE Using the **Next Window** key, you can scroll through the measurement displays, where the current selection is highlighted with a green box outline. The **Zoom** key will zoom in on the currently selected display. To go back to the quad-view display press **Zoom** again.

Figure 2-35 FSK Error versus Symbol

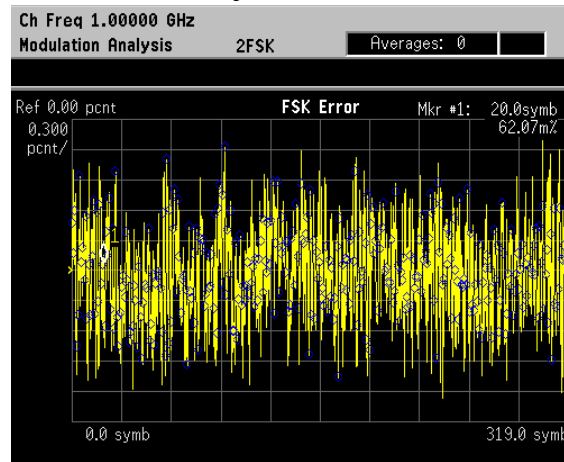

The FSK error measurement display shows FSK error versus symbol. Depending on the number of symbols captured in the **Meas Interval** key, by measurement default parameters, the x-axis displays symbols 0 through 1 minus the **Meas Interval**

Step 4. Change the x-axis settings to zoom in on smaller portion of the measurement capture interval:

Press **SPAN X Scale, Scale/Div, 3, Symbols.**

To place the symbol points on the vertical graticules, use integer symbol values for **Scale/Div**. An alternate method to view less symbols is to reduce the measurement interval with the **Meas Interval** key. If you want to view another portion of the time capture interval, adjust the **Ref Value**.

Figure 2-36 FSK Error versus Symbol (X-Axis Settings)

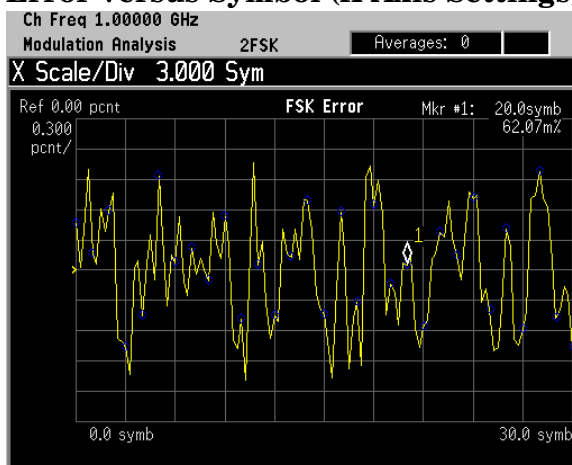

The FSK error measurement displayed in [Figure 2-36](#) shows an x-axis **Scale/Div** of 3 with a measurement capture interval of 256 symbols.

Step 5. Decrease the y-axis settings to increase the resolution of the FSK error results. Use the same x-axis settings from the previous step.

Press **AMPLITUDE Y Scale, Scale/Div, 0.2, %.**

Figure 2-37 FSK Error versus Symbol (Y-Axis Settings)

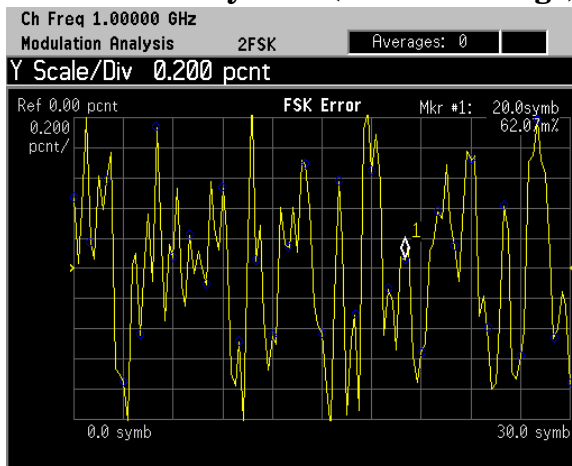

The FSK Error measurement displayed in [Figure 2-37](#) shows a y-axis **Scale/Div** of 0.2 percent and a reference level of 0 percent.

Viewing the FSK Error Spectrum Results

This procedure shows you how to adjust x-axis and y-axis settings for the FSK error spectrum graph.

NOTE

In this procedure, a bursted Bluetooth 2-level FSK signal is used with a symbol rate of 1 Msps, and a filter alpha of 0.5 at 1 GHz.

If you have a problem, and get an error message, see “[Interpreting Error Codes](#)” on page 119.

Step 1. Follow steps 1 through 5 in the procedure “[Viewing the FSK Error \(Quad-View\) Results](#)” on page 77 before continuing.

Step 2. View the FSK error quad-view (see [Figure 2-34](#)):

Press **Trace/View, FSK Error (Quad-View)**.

Step 3. View the zoomed in graph of FSK error spectrum. Use markers to look at frequency points of the error spectrum.

Press **Next Window** until the FSK error spectrum graph is selected.

Press **Zoom**.

Press **Marker, Trace, FSK Error Spectrum**, then use the numeric keypad or front-panel knob to place the marker on a frequency point.

NOTE

Using the **Next Window** key, you can scroll through the measurement displays, where the current selection is highlighted with a green box outline. The **Zoom** key will zoom in on the currently selected display. To go back to the quad-view display press **Zoom** again.

Figure 2-38 FSK Error Spectrum

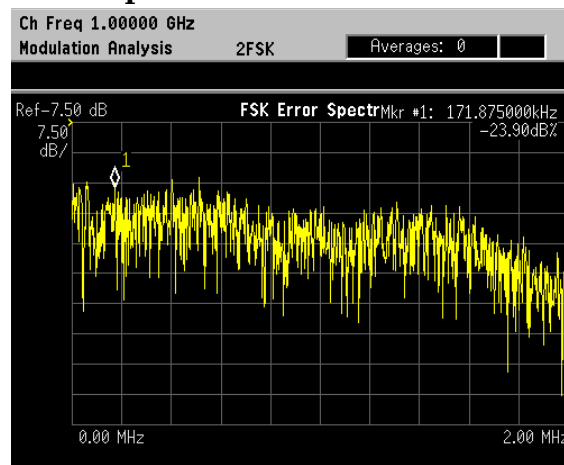

When you select FSK error spectrum, the analyzer displays the spectrum of FSK error versus time. In other words, the analyzer derives the FSK error time trace, and then windows and FFTs this trace to produce the FSK error spectrum trace.

Step 4. Change the x-axis settings to zoom in on smaller portion of the error spectrum:

Press **SPAN X Scale, Scale/Div, 20, kHz.**

Figure 2-39 FSK Error Spectrum (X-Axis Settings)

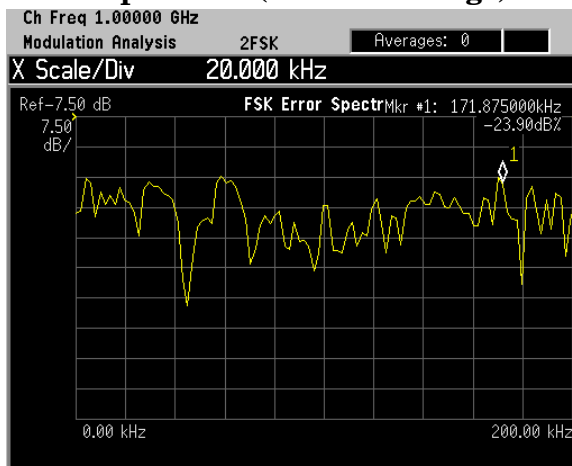

The FSK Error Spectrum measurement displayed in [Figure 2-39](#) shows an x-axis **Scale/Div** of 20 kHz.

Step 5. Decrease the y-axis settings to increase the resolution of the FSK error spectrum results. Use the same x-axis settings from the previous step.

Press **AMPLITUDE Y Scale, Scale/Div, 5, dB.**

Figure 2-40 FSK Error Spectrum (Y-Axis Settings)

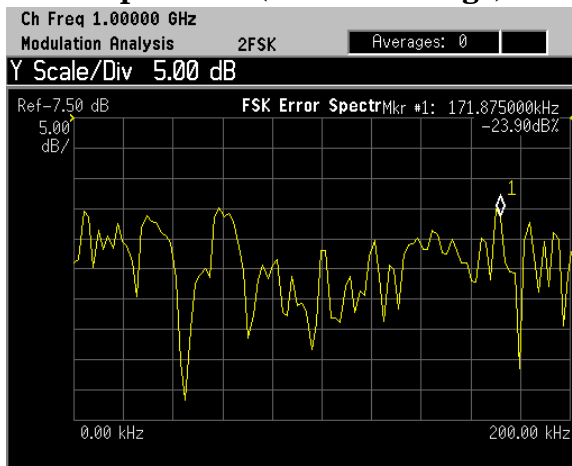

The FSK Error Spectrum measurement displayed in [Figure 2-40](#) shows a y-axis **Scale/Div** of 5 dB and a reference level of -7.5 dB.

Viewing the FSK Measured Time Results

This procedure shows you how to adjust x-axis and y-axis settings for the FSK measured time graph.

NOTE

In this procedure, a bursted Bluetooth 2-level FSK signal is used with a symbol rate of 1 Msps, and a filter alpha of 0.5 at 1 GHz.

If you have a problem, and get an error message, see “[Interpreting Error Codes](#)” on page 119.

Step 1. Follow steps 1 through 5 in the procedure “[Viewing the FSK Error \(Quad-View\) Results](#)” on page 77 before continuing.

Step 2. View the FSK error quad-view (see [Figure 2-34](#)):

Press **Trace/View, FSK Error (Quad-View)**.

Step 3. View the zoomed in graph of FSK measured time. Use markers to look at the measured symbol points.

Press **Next Window** until the FSK measured time graph is selected.
Press **Zoom**.

Press **Marker, Trace, FSK Measured**, then use the numeric keypad or front-panel knob to place the marker on a symbol.

NOTE

Using the **Next Window** key, you can scroll through the measurement displays, where the current selection is highlighted with a green box outline. The **Zoom** key will zoom in on the currently selected display. To go back to the quad-view display press **Zoom** again.

Figure 2-41 FSK Measured Time

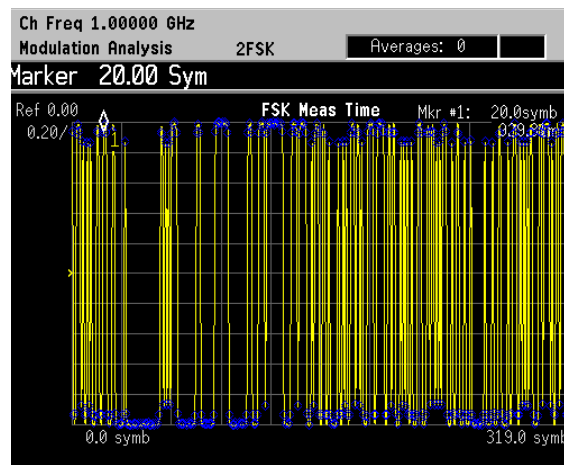

The FSK measured time display shows the symbol decision points versus time. Depending on the number of symbols captured in the **Meas Interval** key, by measurement default parameters, the x-axis displays symbols 0 through 1 minus the **Meas Interval**

Step 4. Change the x-axis settings to zoom in on smaller portion of the measurement capture interval:

Press **SPAN X Scale, Scale/Div, 3, Symbols.**

To place the symbol points on the vertical graticules, use integer symbol values for **Scale/Div**. An alternate method to view less symbols is to reduce the measurement interval with the **Meas Interval** key. If you want to view another portion of the time capture interval, adjust the **Ref Value**.

Figure 2-42 FSK Measured Time (X-Axis Settings)

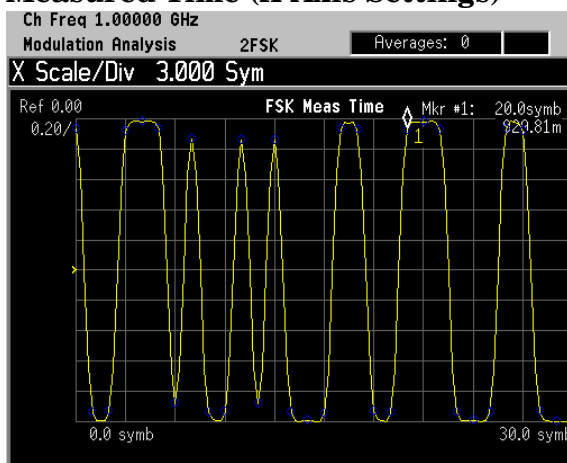

The FSK Meas Time display in [Figure 2-42](#) shows an x-axis **Scale/Div** of 3 symbols per division with a measurement interval of 320 symbols.

Step 5. Increase the y-axis settings to observe how y-axis scaling works. Use the same x-axis settings from the previous step.

Press **AMPLITUDE Y Scale, Scale/Div, 0.3, Enter.**

Figure 2-43 FSK Measured Time (Y-Axis Settings)

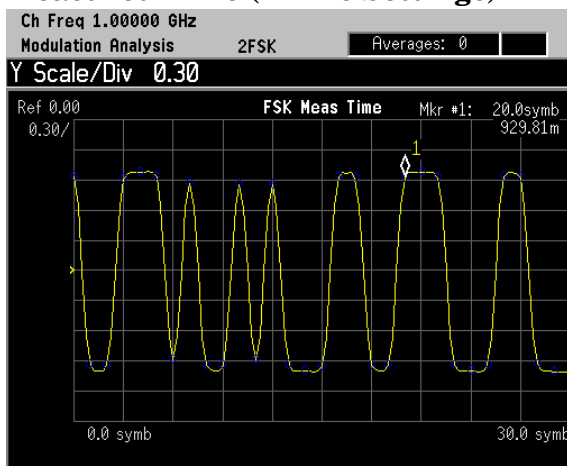

The FSK Measured Time display in [Figure 2-43](#) shows a y-axis **Scale/Div** of 0.3 and a reference value of 0.

PSK Modulation Analysis (cdma2000 QPSK Example)

Supported PSK formats: BPSK, QPSK, 8PSK, DQPSK, D8PSK, Pi/4 DQPSK and Offset QPSK.

This section explains how to demodulate and analyze a cdma2000 signal (pilot channel only) at 1 GHz and -10 dBm. This measurement procedure guides you through the different measurement views useful for modulation analysis.

Configuring the Measurement System

Refer to “[Configuring a BTS Measurement System](#)” on page 29 to connect the measurement equipment.

Measurement Procedure

If you have a problem, and get an error message, see “[Interpreting Error Codes](#)” on page 119.

Step 1. Preset the instrument and select the digital modulation personality:

Press **Preset, Factory Preset** (if available).
Press **MODE, Digital Modulation**.

Step 2. Select the cdma2000 radio standard pre-set and base station device:

Press **Mode Setup, Radio, Radio Standard, cdma2000**.
Press **Device (BTS)**, to underline BTS.

Step 3. Enable the modulation analysis mode to measure and display EVM and other modulation metrics.

Press **MEASURE, Modulation Analysis**.

Figure 2-44

I/Q Measured Polar Vector Graph (Default View)

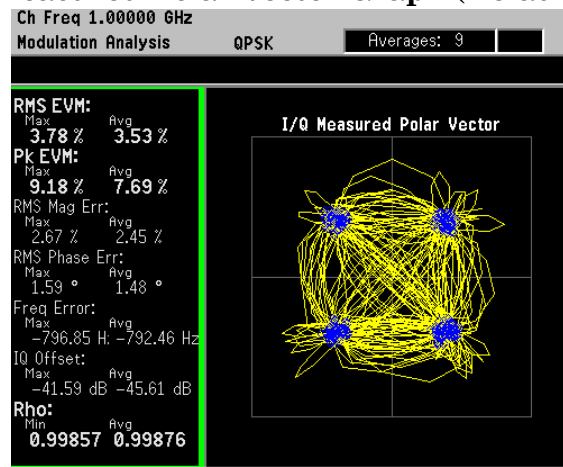

The measurement values for EVM, magnitude error, phase error, frequency error, I/Q offset and rho are shown in the summary window on the left side of the display.

Step 4. View the I/Q error quad-view display to view the magnitude and phase error components versus time and EVM versus time to quickly pin-point possible modulation problems:

Press **Trace/View, I/Q Error (Quad-View)**.

Figure 2-45 I/Q Error (Quad-View)

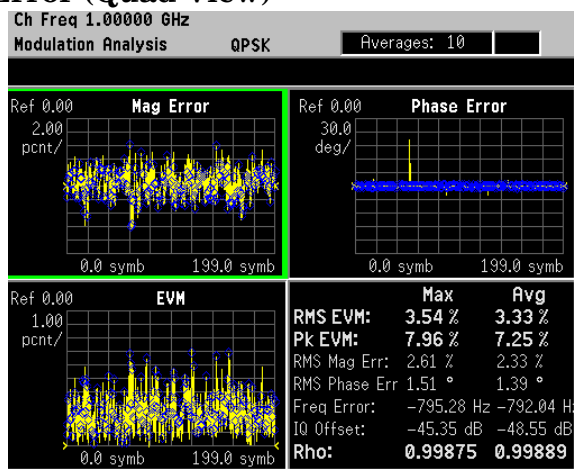

Step 5. View the eye quad-view display to quickly determine if the eye I and eye Q diagrams are symmetrical with good symbol transitions.

Press **Trace/View, Eye (Quad-View)**.

Figure 2-46 Eye (Quad-View)

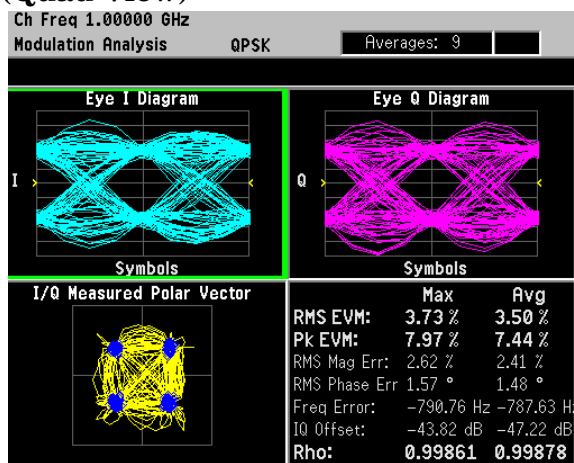

QAM Modulation Analysis (64QAM Example)

Supported QAM formats: 16QAM, 32QAM, 64QAM, 128QAM and 256QAM.

This section explains how to demodulate and analyze a 64QAM signal at 1 GHz, -10 dBm with a root nyquist filter alpha of 0.25 and a symbol rate of 5 Msps. This measurement procedure guides you through the different measurement views useful for modulation analysis.

Measurement Procedure

If you have a problem, and get an error message, see [“Interpreting Error Codes”](#) on page 119.

Step 1. Preset the instrument and select the digital modulation personality:

Press **Preset, Factory Preset** (if available).
Press **MODE, Digital Modulation**.
Press **MEASURE, Modulation Analysis**.

Step 2. Modify the demodulation parameters:

Press **Meas Setup, Demod**.
Press **Modulation Format, More, 64QAM**.
Press **Meas Filter, Root Nyquist**.
Press **Ref Filter, Nyquist**.
Press **Alpha/BT, 0.25, Enter**.
Press **Symbol Rate, 5, MHz**.

Figure 2-47

I/Q Measured Polar Vector Graph (Default View)

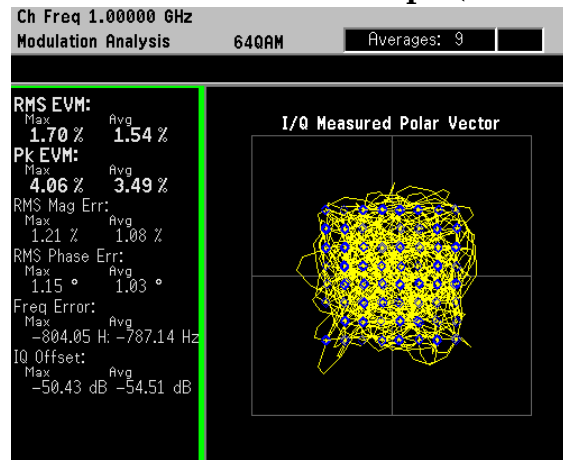

The measurement values for EVM, magnitude error, phase error, frequency error, I/Q offset and rho are shown in the summary window on the left side of the display.

Step 3. View the I/Q error quad-view display to view the magnitude and phase error components versus time and EVM versus time to quickly pin-point possible modulation problems:

Press **Trace/View, I/Q Error (Quad-View)**.

Figure 2-48

I/Q Error (Quad-View)

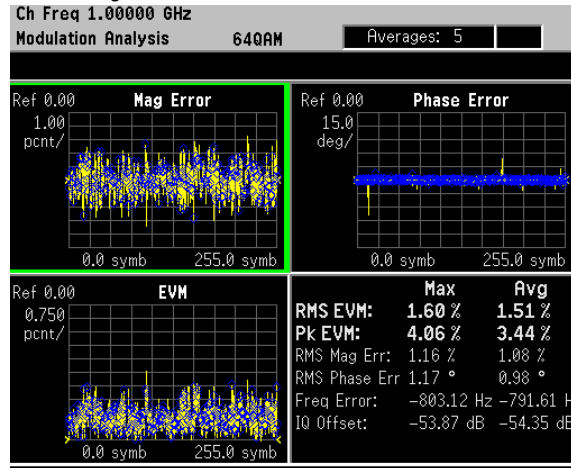

Step 4. View the eye quad-view display to quickly determine if the eye I and eye Q diagrams are symmetrical with good symbol transitions.

Press **Trace/View, Eye (Quad-View)**.

Figure 2-49

Eye (Quad-View)

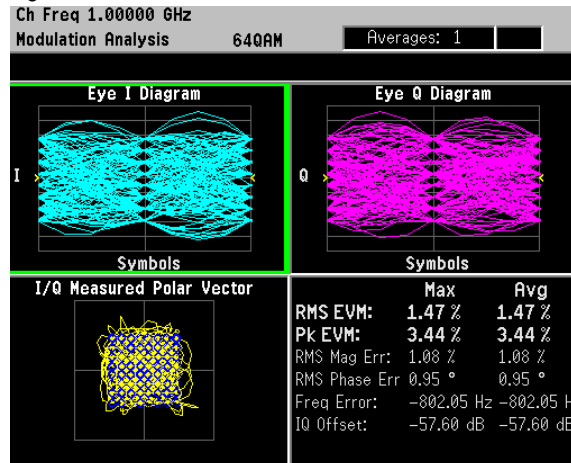

EDGE Modulation Analysis

This section explains how to demodulate and analyze an EDGE signal at 1 GHz, -10 dBm. This measurement procedure guides you through the different measurement views useful for modulation analysis.

Configuring the Measurement System

Refer to “[Configuring a BTS Measurement System](#)” on page 29 to connect the measurement equipment.

Measurement Procedure

If you have a problem, and get an error message, see “[Interpreting Error Codes](#)” on page 119.

Step 1. Preset the instrument and select the digital modulation personality:

Press **Preset, Factory Preset** (if available).
Press **MODE, Digital Modulation**.

Step 2. Select the EDGE radio standard pre-set and base station device:

Press **Mode Setup, Radio, Radio Standard, EDGE**.
Press **Device** (BTS), to underline BTS.

Step 3. Enable the modulation analysis mode to measure and display EVM and other modulation metrics.

Press **MEASURE, Modulation Analysis**.

Figure 2-50

I/Q Measured Polar Vector Graph (Default View)

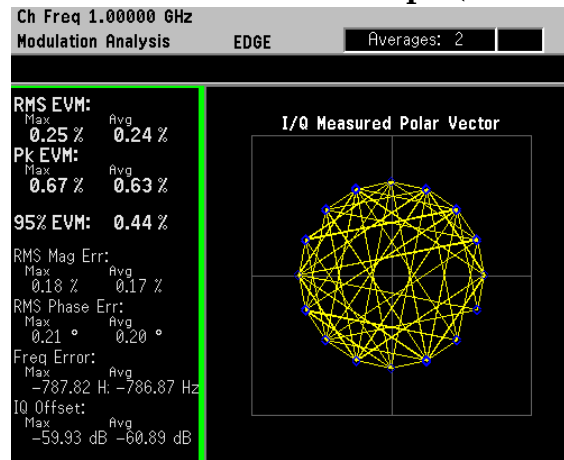

The measurement values for EVM, magnitude error, phase error, frequency error, I/Q offset and rho are shown in the summary window on the left side of the display.

Step 4. View the I/Q error quad-view display to view the magnitude and phase error components versus time and EVM versus time to quickly pin-point possible modulation problems:

Press **Trace/View, I/Q Error (Quad-View)**.

Figure 2-51 I/Q Error (Quad-View)

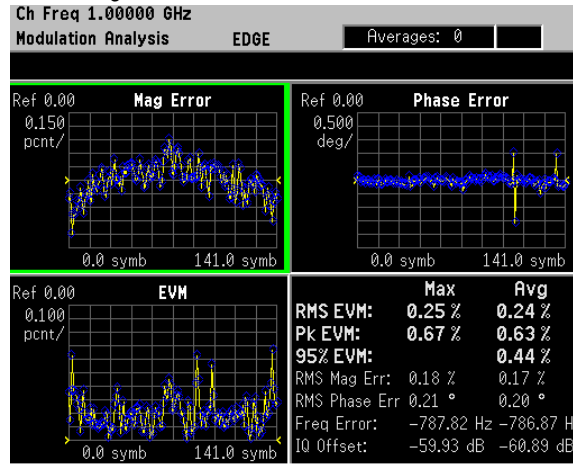

Step 5. View the eye quad-view display to quickly determine if the eye I and eye Q diagrams are symmetrical with good symbol transitions.

Press **Trace/View, Eye (Quad-View)**.

Figure 2-52 Eye (Quad-View)

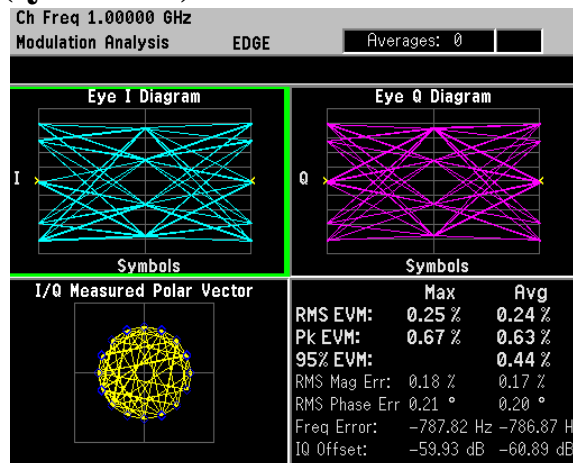

FSK Modulation Analysis (Bluetooth 2FSK Example)

Supported FSK formats: 2FSK, 4FSK and 8FSK.

This section explains how to demodulate and analyze a bursted Bluetooth signal at 1 GHz, -10 dBm. This measurement procedure guides you through the different measurement views useful for modulation analysis.

Measurement Procedure

If you have a problem, and get an error message, see “[Interpreting Error Codes](#)” on page 119.

- Step 1.** Preset the instrument and select the digital modulation personality:
Press **Preset, Factory Preset** (if available).
Press **MODE, Digital Modulation**.
- Step 2.** Select the Bluetooth radio standard pre-set:
Press **Mode Setup, Radio, Radio Standard, More, Bluetooth**.
- Step 3.** Enable the modulation analysis mode to measure and display EVM and other modulation metrics.
Press **MEASURE, Modulation Analysis**.
- Step 4.** Set the trigger source to capture the Bluetooth burst:
Press **Meas Setup, Trig Source, RF Burst (Wideband)**.
Press **Meas Control, Restart**.

Figure 2-53

I/Q Measured Polar Vector Graph (Default View)

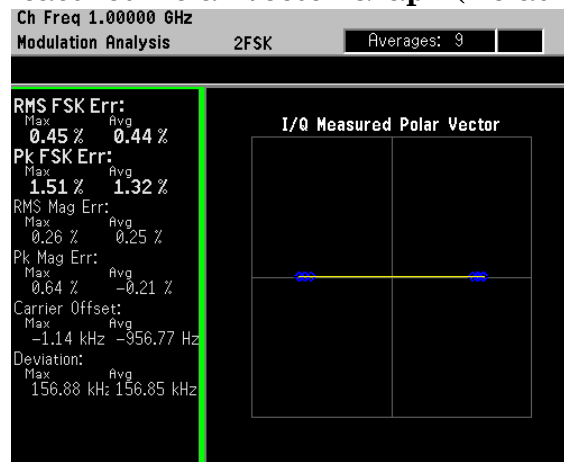

In [Figure 2-53](#), the measurement values for FSK error, magnitude error, carrier offset and deviation are shown in the summary window on the left side of the display.

Step 5. View the FSK error quad-view display:

Press **Trace/View, FSK Error (Quad-View)**.

The FSK error quad-view display contains FSK error versus time, FSK error spectrum, FSK measured time and a numeric summary table. You can zoom in on any of these views for better resolution.

Figure 2-54 FSK Error (Quad-View)

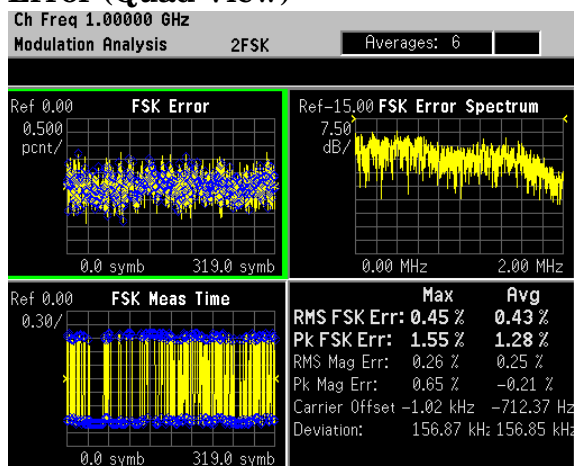

Step 6. View the numeric results table to quickly determine where problems might exist in the modulation.

Press **Trace/View, Numeric Results**.

Figure 2-55 FSK Numeric Results



MSK Modulation Analysis (GSM MSK type 1 Example)

Supported MSK formats: MSK type 1 and MSK type 2.

This section explains how to demodulate and analyze a GSM signal at 1 GHz and -10 dBm. This measurement procedure guides you through the different measurement views useful for modulation analysis.

Configuring the Measurement System

Refer to “Configuring a BTS Measurement System” on page 29 to connect the measurement equipment.

Measurement Procedure

If you have a problem, and get an error message, see “Interpreting Error Codes” on page 119.

Step 1. Preset the instrument and select the digital modulation personality:

Press **Preset, Factory Preset** (if available).
Press **MODE, Digital Modulation**.

Step 2. Select the GSM radio standard pre-set and base station device:

Press **Mode Setup, Radio, Radio Standard, GSM**.
Press **Device (BTS)**, to underline BTS.

Step 3. Enable the modulation analysis mode to measure and display EVM and other modulation metrics.

Press **MEASURE, Modulation Analysis**.

Figure 2-56

I/Q Measured Polar Vector Graph (Default View)

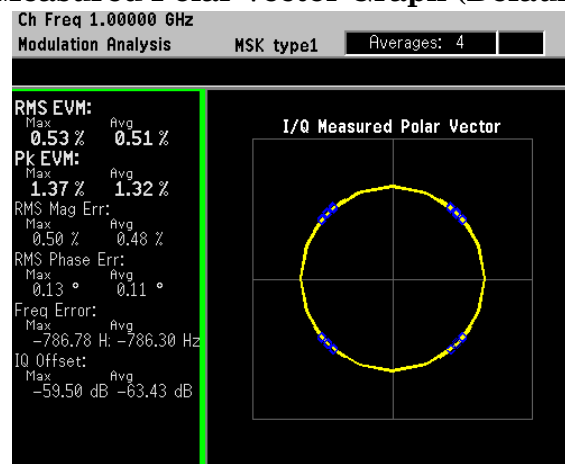

The measurement values for EVM, magnitude error, phase error, frequency error and I/Q offset are shown in the summary window on the left side of the display.

Step 4. View the I/Q error quad-view display to view the magnitude and phase error components versus time and EVM versus time to quickly pin-point possible modulation problems:

Press **Trace/View, I/Q Error (Quad-View)**.

Figure 2-57 I/Q Error (Quad-View)

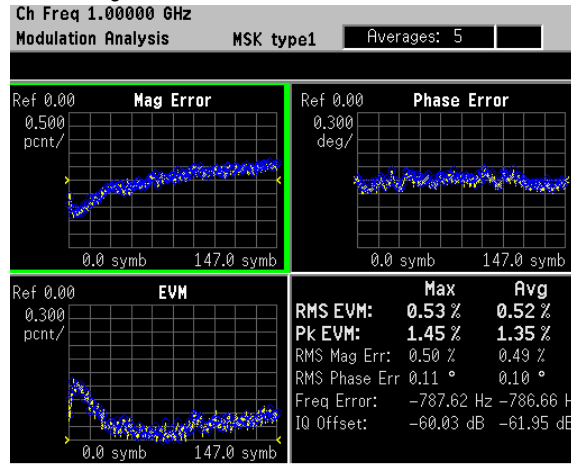

Step 5. View the eye quad-view display to quickly determine if the eye I and eye Q diagrams are symmetrical with good symbol transitions.

Press **Trace/View, Eye (Quad-View)**.

Figure 2-58 Eye (Quad-View)

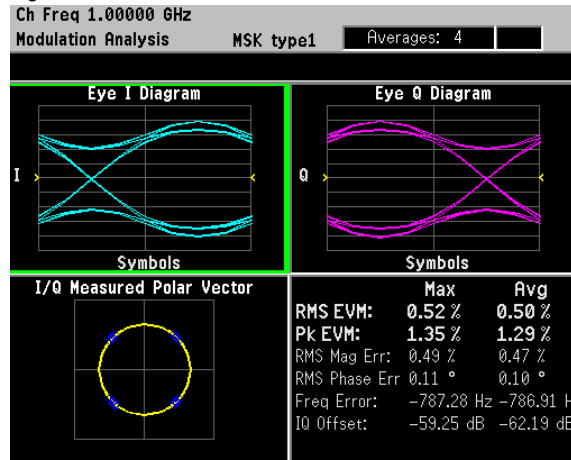

Analyzing and Troubleshooting Digital Signals

EVM Troubleshooting Procedure Overview

Measurements of EVM and related quantities can pin-point the causes of many problems uncovered during the design stages. This section provides general guidance for troubleshooting those problems and the techniques to determine what kind of impairments could be due to your design or testing procedure. Figure 2-59 shows the troubleshooting procedure to help determine the root cause of your measurement results.

If you have high EVM results, the first step is to break the EVM result into phase and magnitude components. With phase and magnitude errors, you can determine whether you need to view phase error vs. time, magnitude error vs. time or the I/Q constellation. For example, if you determined the phase error and magnitude error add about the same amount of error to the EVM result and the I/Q constellation is symmetric then you should look closely at EVM vs. time.

Figure 2-59 Flow Chart for EVM Troubleshooting

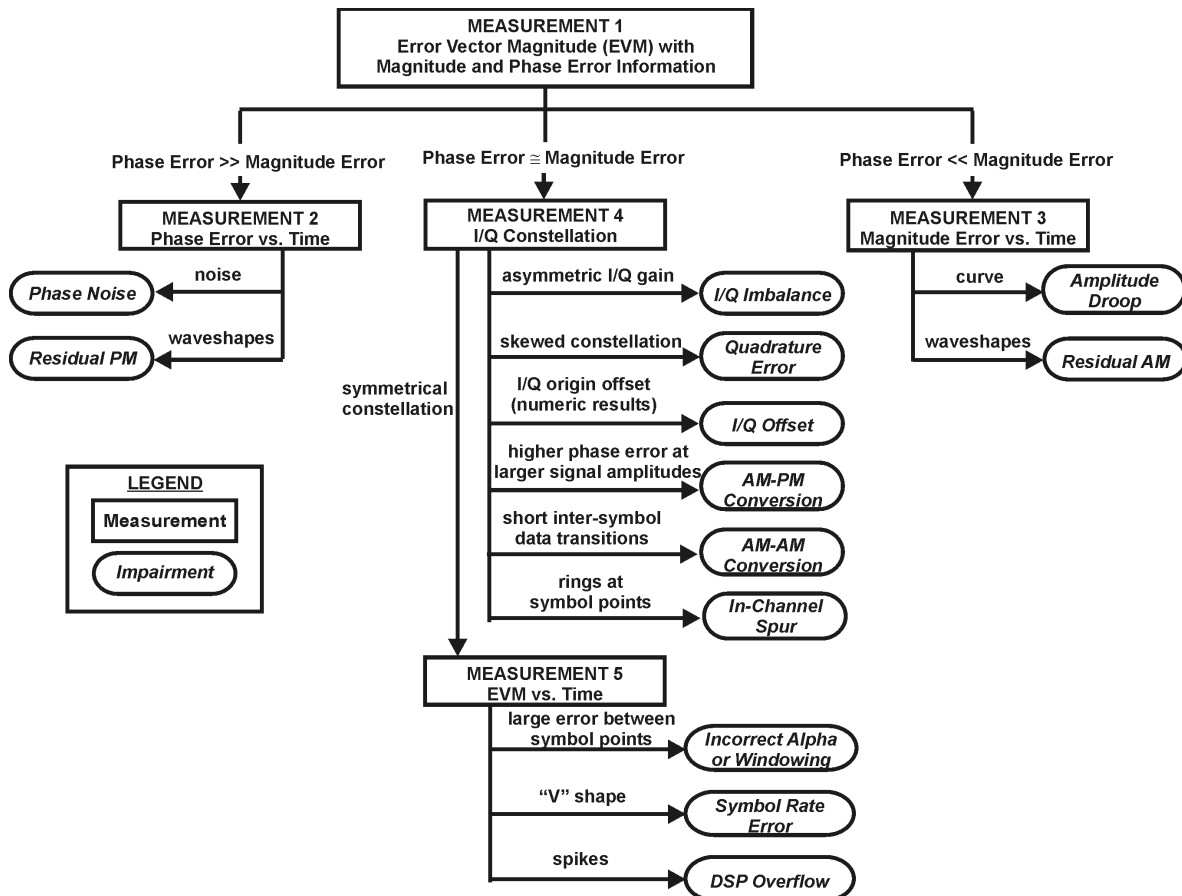

Measurement 1 - Obtaining EVM Results with Phase Error and Magnitude Error

The PSA Option 241 can help design engineers pin-point signal errors or measurement set-up errors from basic digitally modulated signals to complex digitally modulated high data rate signals.

To demonstrate using PSA option 241 for troubleshooting signal and set-up impairments, a W-CDMA signal is used.

Step 1. Generate a downlink (base station) W-CDMA signal with 1 data channel (DPCH). Set the carrier frequency at 1 GHz with an amplitude of -10 dBm. The W-CDMA signal is impairment free.

Step 2. Setup the PSA to demodulate the W-CDMA signal using option 241:

Press **Preset, Factory Preset** (if available).

Press **MODE, Digital Modulation**.

Press **FREQUENCY Channel, Center Freq, 1, GHz**.

Press **MEASURE, Modulation Analysis**.

Step 3. View the numeric results and note the average (RMS) EVM, RMS magnitude error and RMS phase error results:

Press **Trace/View, Numeric Results**.

If you have higher than expected RMS and/or peak EVM results, look at the RMS magnitude error (number 1 in [Figure 2-60](#)) and RMS phase error (number 2 in [Figure 2-60](#)). If the phase error is relatively larger (greater than 3-4 times) than the magnitude error go to [“Measurement 2 - Phase Error vs. Time”](#) on page 97. If the magnitude error is relatively larger (greater than 3-4 times) than the phase error go to [“Measurement 3 - Magnitude Error vs. Time”](#) on page 98. If the phase error and magnitude error are approximately the same go to [“Measurement 4 - I/Q Constellation Diagram”](#) on page 99.

Figure 2-60

Numeric Results (comparing phase and magnitude errors)

Modulation Analysis		QPSK	Averages: 2
	Max		Avg
RMS EVM	1.21 %		1.16 %
Peak EVM	2.55 % at sym 115		2.53 % at sym 10
RMS Mag Error ①	0.85 %		0.80 %
Peak Mag Error	2.43 % at sym 10		0.13 % at sym 10
RMS Phase Error ②	0.49 °		0.48 °
Peak Phase Error	-1.44 ° at sym 115		-1.39 ° at sym 56
Frequency Error	-787.79 Hz		-783.45 Hz
IQ Offset	-53.93 dB		-54.09 dB
Quadrature Skew	0.00 °		0.00 °
IQ Gain Imbalance	-0.02 dB		0.03 dB
SNR(MER)	Min 39.35 dB		39.73 dB
Rho	Min 0.99985		0.99987

Measurement 2 - Phase Error vs. Time

Measurement procedure: use if phase error \gg magnitude error.

Description: Phase error is the instantaneous angle difference between the measured signal and the ideal reference signal. When viewed as a function of time (or symbol), it shows the modulating waveform of any residual or interfering PM signal.

Step 1. Display the phase error versus time (symbols) results:

Press **Trace/View, I/Q Error (Quad-View)**.
Press **Next Window, Zoom**.

The full screen view should now be the phase error diagram.

Step 2. Adjust the vertical scale as necessary to view the phase error:

Press **AMPLITUDE Y Scale, Scale/Div** then adjust as necessary.

By manually changing the **Scale/Div**, the **Scale Coupling** turns *off*. If you are not sure what **Scale/Div** to use, set **Scale Coupling** to *on*.

Step 3. For more detail, expand the waveform by reducing the result length or by reducing the x-scale per division.

Press **Meas Setup, Demod, Meas Interval**, or
Press **SPAN X Scale, Scale/Div**, then adjust the measurement interval or x-axis as necessary.

TIP

The x-axis scale is in symbols. To calculate absolute time, divide the number of symbols by the symbol rate.

Observe: Sine waves or other regular waveforms indicate an interfering signal. See [“In-Channel Phase Modulating \(PM\) Interference” on page 107](#) for an example of residual PM. Uniform noise is a sign of some form of phase noise (i.e. random jitter). See [Figure 2-61](#) for an example.

Figure 2-61

Phase Error Zoom View - Example of Uniform Noise

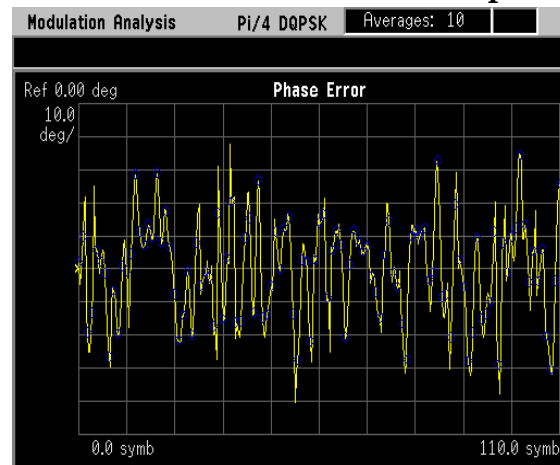

Measurement 3 - Magnitude Error vs. Time

Measurement procedure: use if phase error \ll magnitude error.

Description: Magnitude error is the instantaneous amplitude difference between the measured signal and the ideal reference signal. When viewed as a function of time (or symbol), it shows the modulating waveform of any residual or interfering AM signal.

Step 1. Display the magnitude error versus time (symbols) results:

Press **Trace/View, I/Q Error (Quad-View)**. (Confirm the current selected view is Mag Error. The current selection is outlined in green.)

Press **Zoom**.

NOTE

If you need to go back to the quad-view, press **Zoom** one more time.

The full screen view should now be the magnitude error diagram.

Step 2. Adjust the vertical scale as necessary to view the magnitude error:

Press **AMPLITUDE Y Scale, Scale/Div** then adjust as necessary.

By manually changing the **Scale/Div**, the **Scale Coupling** turns *off*. If you are not sure what **Scale/Div** to use, set **Scale Coupling** to *on*.

Step 3. For more detail, expand the waveform by reducing the result length or by reducing the x-scale per division.

Press **Meas Setup, Demod, Meas Interval**, or

Press **SPAN X Scale, Scale/Div**, then adjust the measurement interval or x-axis as necessary.

If magnitude error versus time shows a curve response then amplitude droop could be the problem. If you see a waveform pattern then residual AM could be the problem. See [“In-Channel Amplitude Modulation \(AM\) Interference” on page 109](#) for an example of residual AM.

Figure 2-62

Magnitude Error Zoom View - Example of Uniform Noise

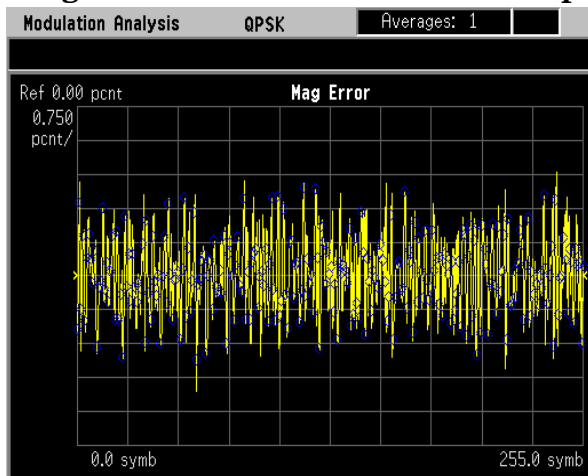

Measurement 4 - I/Q Constellation Diagram

Measurement procedure: use if phase error \cong magnitude error.

Description: This is a common graphical analysis technique utilizing a polar plot to display a vector-modulated signal's magnitude and phase relative to the carrier, as a function of time or symbol. The phasor values at the symbol clock times are particularly important, and are highlighted with a dot (at a symbol point). In order to accomplish this, a constellation analyzer must know the precise carrier and symbol clock frequencies and phases, either through an external input or through automatic locking, as with PSA Option 241.

Step 1. Display the I/Q measured time polar constellation graph (default view):

Press **Trace/View, I/Q Measured Polar Graph.**

The individual constellation “dots” represent the modulation symbol states. The lines connecting the states are the signal “trajectories” for the phase and amplitude of the modulation between symbols.

Step 2. Adjust the number of I/Q points displayed in the constellation view:

Press **Display, I/Q Points.**

For a constellation with a low number of symbol states, enter a number at least several times the number of states in the constellation. That will allow each state to clearly show the distribution of measured symbols. If no symbol “dot” is shown, it may mean that state was not transmitted. You may need to use random data to see all the “dots”.

TIP **I/Q Points** determines how many dots will appear on the constellation. Increase it to populate the constellation states more completely. **I/Q Points** cannot exceed the measurement interval.

If you are examining a constellation that contains a large number of symbol states, like 256QAM, it may become difficult to see individual trajectories. It can be helpful to limit the number of “dots” shown by adjusting the number of symbols displayed lower than the number of symbol states in the constellation, and repeating the measurement to “see” all the constellation dots and the trajectories.

Step 3. Adjust the number of points/symbol displayed in the constellation view:

Press **Display, Points/Symbol.**

TIP **Points/symbol** determines how much detail is shown between symbols. To see peaks and overshoot due to filter errors, use four or more points/symbol.

To allow a longer result length, use fewer points (in either case, result length multiplied by points/symbol must be less than max time points).

One point per symbol creates misleading eye and constellation diagrams, because no intersymbol data is collected and all symbols are connected by straight, direct lines.

Step 4. Check the I/Q constellation for symmetry.

Observe: A perfect signal will have a uniform constellation that is perfectly symmetric about the origin. Asymmetrical constellations fall into the following categories:

- I/Q imbalance (“I/Q Gain Imbalance” on page 103) is indicated when the constellation is not “square,” that is when the Q-axis height does not equal the I-axis width.
- Quadrature error (“I/Q Quadrature Skew” on page 105) is seen as a “tilt” to the constellation.
- I/Q offset (“I/Q DC Offset Error” on page 106) shows up as a numeric result, since the PSA only reports the value and adjusts the constellation to remove any offset.

Step 5. In some cases it may be easier to spot modulation problems if the symbol trajectories are turned off:

Press **Display, I/Q Polar Type, Constellation**.

Typical problems that can be easily identified by viewing the constellation points are compression and interfering spurious signals. Compression is the result of higher phase errors at larger signal amplitudes.

- Interfering spur - “In-Channel Spurious Signal Interference” on page 111 shows up as rings at the symbol points.
- Compression - symbol point shadowing effect

Step 6. If the constellation is symmetric with no abnormalities, continue to measurement 5, to analyze EVM versus time.

Figure 2-63 I/Q Measured Polar Vector (Left) and Constellation (Right)

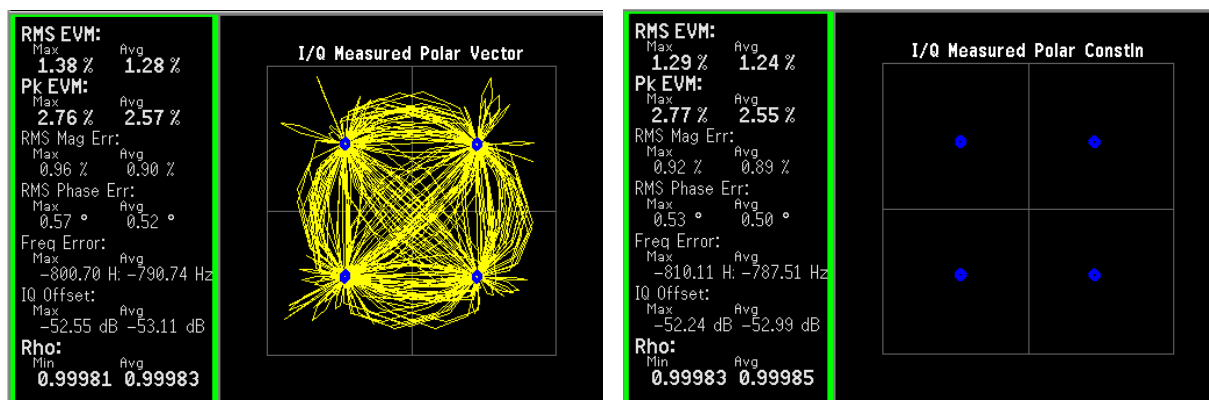

Measurement 5 - Error Vector Magnitude vs. Time

Measurement procedure: use if phase error \cong magnitude error and the constellation is symmetrical.

Description: EVM is the difference between the input signal and the internally generated ideal reference. When viewed as a function of symbols or time, errors may be correlated to specific points on the input waveform, such as peaks or zero crossings. EVM is a scalar (magnitude) value expressed as a percentage.

EVM vs. time can help troubleshoot setup problems, and can help validate that measured errors are not residual in nature.

Step 1. Display the EVM versus time graph:

Press **Trace/View, I/Q Error (Quad-View)**.

Press **Next Window** (until the EVM graph is selected), **Zoom**.

Step 2. Adjust the vertical scale as necessary:

Press **AMPLITUDE Y Scale, Scale/Div** then adjust as necessary.

By manually changing the **Scale/Div**, the **Scale Coupling** turns *off*.

Step 3. For more detail, expand the waveform by reducing the result length or by reducing the x-scale per division.

Press **Meas Setup, Demod, Meas Interval**, or

Press **SPAN X Scale, Scale/Div**, use integer values if you want the symbols to occur on the vertical graticules.

Step 4. Use EVM vs. time to spot modulation or setup problems:

- Filter Problems - incorrect alpha or windowing (“[Baseband Filtering Errors](#)” on page 113) shows large errors between symbol points.
- Symbol Rate Error - (“[Symbol Rate Error](#)” on page 115) shows up as a v-shape trace in the EVM vs time display.
- DSP Overflow - shows large spikes in the EVM vs. time display.

Figure 2-64

EVM vs. Time Zoom View - Uniform Noise

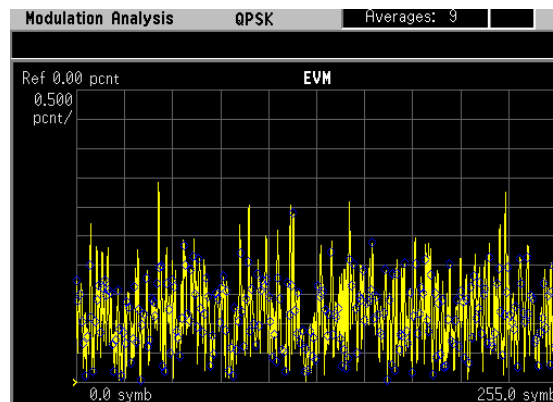

Interpreting Measurement Results (Impairments)

This section illustrates how to recognize major symptoms of problems in signal modulation quality, including external interference.

A W-CDMA base station signal (with one data channel) is used to demonstrate impairments. The steps to setup impairments on the Agilent ESG signal source are not documented in the following procedures. The following procedures are used to describe what your results could look like using PSA Option 241 to troubleshoot radio signal errors.

The following signal impairments are investigated in this section:

- “I/Q Gain Imbalance” on page 103
- “I/Q Quadrature Skew” on page 105
- “I/Q DC Offset Error” on page 106
- “In-Channel Phase Modulating (PM) Interference” on page 107
- “In-Channel Amplitude Modulation (AM) Interference” on page 109
- “In-Channel Spurious Signal Interference” on page 111
- “Signal Compression” on page 117
- “Baseband Filtering Errors” on page 113
- “Symbol Rate Error” on page 115

I/Q Gain Imbalance

Since I and Q are two separate signals, each one is created and amplified independently. Inequality of the gain between the I and Q paths results in an incorrect positioning of each symbol in the constellation, causing errors in the recovered data. Gain imbalance can be caused by matching problems due to component differences (filters, amplifiers, DACs, etc.) between the I side and Q side of a network.

In this example, the ESG I/Q impairments have added a 2 dB I/Q gain imbalance to the W-CDMA base station signal.

Step 1. View the I/Q gain impairment in the I/Q polar constellation graph:

Press **Trace/View, I/Q Measured Polar Graph**.
Press **Display, I/Q Polar Type, Constellation**.

Notice that the QPSK constellation is rectangular instead of square. With the constellation continuously shifting by 90 degrees, it is not easy to see that the gain in the Q axis is less than that of the I axis. To see this better, pause the measurement.

Step 2. Pause the measurement to stop the signal rotating about the axes:

Press **Meas Control, Pause**.

For non-scrambled or spread QPSK signals, the symptom of this imbalance is indicated by rectangular-shaped groupings of symbol decision points in each quadrant.

NOTE

If there is no SyncWord to lock to, the analyzer arbitrarily assigns the demodulated symbols to the I and Q channels for each new time record; the analyzer acts as an asynchronous receiver. For this reason, it is not possible to determine the correct carrier phase reference.

Figure 2-65

Polar Constellation Showing an I/Q Gain Imbalance

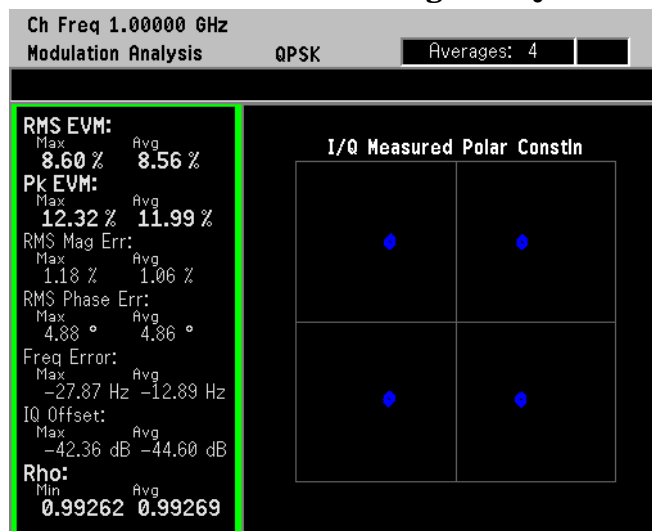

Step 3. View the eye quad-view display:

Press **Trace/View, Eye (Quad-View)**.

Notice the gain imbalance between the eye I and eye Q diagrams in [Figure 2-66](#).

Figure 2-66 Eye Diagram Showing I/Q Gain Imbalance

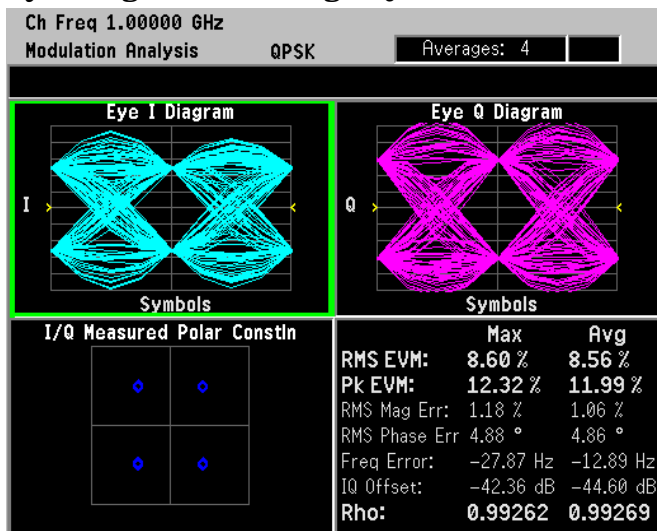

I/Q Quadrature Skew

Quadrature error occurs when the local oscillator signal at either the RF or IF mixes with the I and Q channels of a transmitter. With quadrature skew, the I and Q channels are not operating precisely at 90 degrees to each other. This error manifests itself as a distortion of the constellation and can cause a misinterpretation of the recovered signals.

In this example, the ESG I/Q impairments have added 10 degrees of I/Q quadrature skew to the W-CDMA base station signal.

Step 1. View the I/Q quadrature skew in the I/Q polar constellation graph:

Press **Trace/View, I/Q Measured Polar Graph**.
Press **Display, I/Q Polar Type, Constellation**.

Notice that the QPSK constellation is parallelogram-shaped instead of square.

Step 2. Pause the measurement to stop the signal shifting about the axes:

Press **Meas Control, Pause**.

For non-scrambled or spread QPSK signals, the symptom of quadrature error is indicated by parallelogram-shaped groupings of symbol decision points.

NOTE

If there is no SyncWord to lock to, the analyzer arbitrarily assigns the demodulated symbols to the I and Q channels for each new time record; the analyzer acts as an asynchronous receiver. For this reason, it is not possible to determine the correct carrier phase reference.

Figure 2-67

Polar Constellation Showing I/Q Quadrature Skew

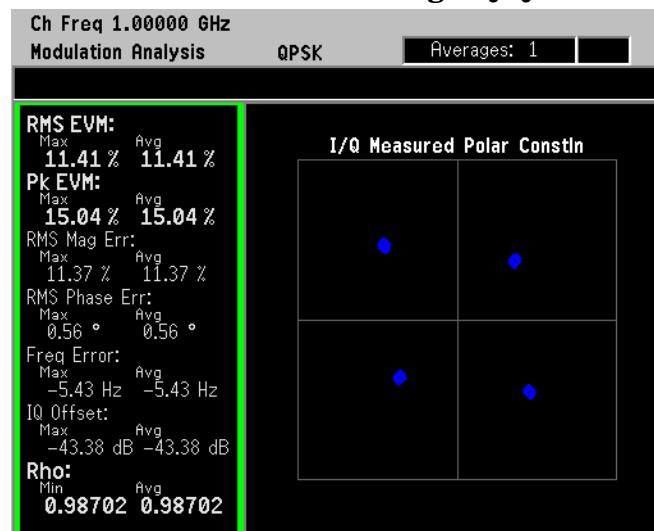

I/Q DC Offset Error

DC offsets may be introduced in the I and Q paths. This error mechanism is a primary indicator of LO feed-through in a transmission system. This in turn can point to potential problems such as an imbalance in the modulator. The DC offsets may also be a result of DC terms being added by components, like the amplifier, in the I and Q paths. Ideally, an error like this shows up as a displaced constellation from the origin of the I/Q plane. However during demodulation, carrier frequency error and IQ offset (also known as IQ origin offset) are measured and removed. These errors are then reported in the error summary table.

In this example, the ESG I/Q impairments have added 10% I offset to the W-CDMA base station signal.

Step 1. Use the I/Q polar constellation diagram to identify I/Q DC offset errors.

Press **Trace/View, I/Q Measured Polar Graph.**

A signal with an I/Q DC offset error is shown in [Figure 2-68](#). Observe that there are no noticeable errors shown in the vector diagram itself. However, the I/Q offset value in the table is about -14 dBc (item 1), and should be closer to -52 dBc for a W-CDMA signal.

Figure 2-68

I/Q Polar Vector Constellation Showing I/Q DC Offset Error

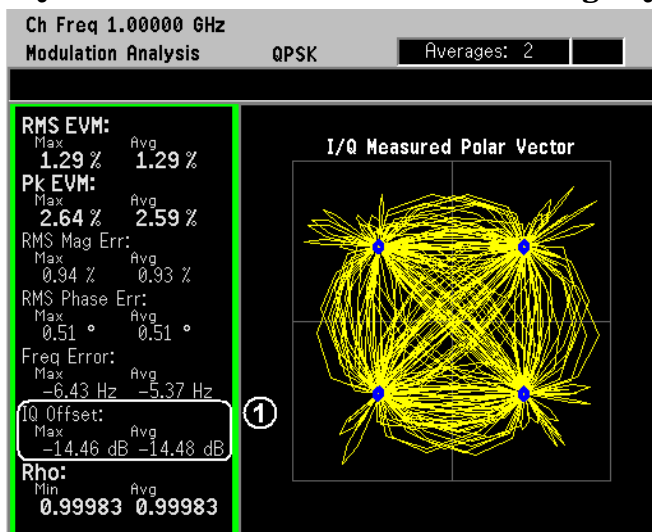

In-Channel Phase Modulating (PM) Interference

Many signals are present in an integrated communications system including digital, baseband, IF, and RF signals. The close proximity of the integrated signals can lead to crosstalk between adjacent components resulting in unwanted signals at the signal output. PSA option 241 can help identify these interfering signals.

The interfering signal causes the amplitude or phase of the transmitted signal to be different each time the signal passes through the same state. PM interference causes a variation of the phase around the ideal symbol reference point.

The results shown were created with a phase modulation deviation of 0.03 pi radians (about 5.5°) and a rate of 45 kHz.

Step 1. View the I/Q polar constellation diagram:

Press **Trace/View, I/Q Measured Polar Graph**.
Press **Display, I/Q Polar Type, Constellation**.

Figure 2-69 shows an example of a W-CDMA signal with in-channel phase modulation interference. Note the variation of phase around the ideal symbol reference points. Also observe how much larger the phase error values are compared to those for magnitude error in the table.

Figure 2-69

I/Q Polar Constellation Showing PM Interference

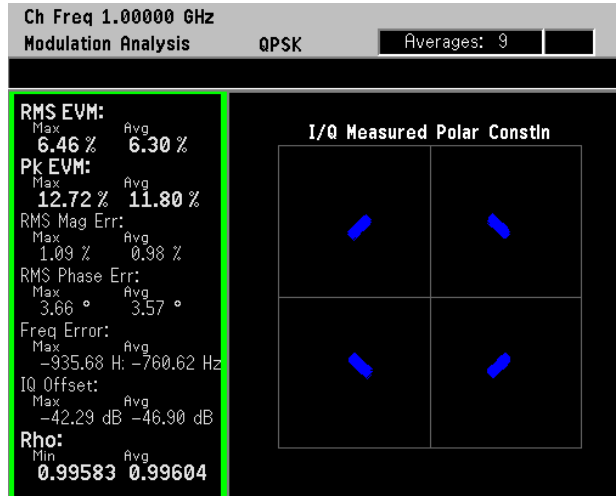

With the interference identified as a PM interference, the next step is to identify the frequency and peak deviation of this PM signal.

Step 2. View the phase error diagram:

Press **Trace/View, I/Q Error (Quad-View)**.

Press **Next Window** (until the Phase Error diagram is selected), **Zoom**.

Step 3. Adjust the y-scale axis to view the waveform:

Press **AMPLITUDE Y Scale, Scale/Div** then adjust as necessary.

In this example the Scale/Div is set to 1.5 deg.

Figure 2-70

Phase Error Graph With PM Interference

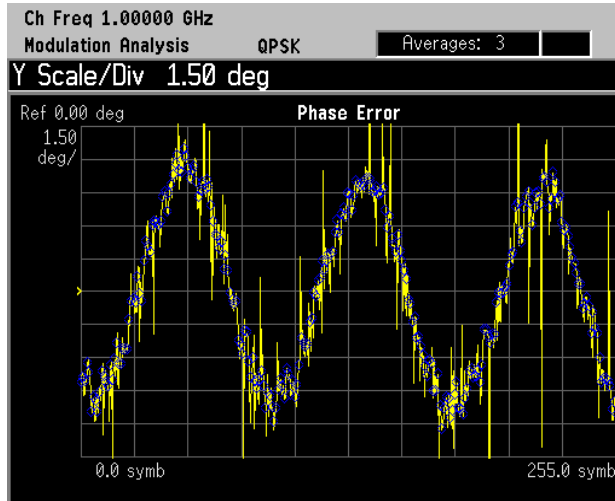

Equation 2-1 **Calculating PM Interference:**

$$\text{Frequency of PM interference} = \left(\frac{\text{No. of cycles}}{\text{symbol}} \right) \left(\frac{\text{No. of symbols}}{\text{second}} \right)$$

In our case we have 3 cycles per 256 symbols and 3.84 Msymbols per second.

Equation 2-2 **PM Interference Example Calculation**

$$\text{Frequency of PM interference} = \left(\frac{3 \text{ cycles}}{256 \text{ symbols}} \right) \left(\frac{3.84 \text{ Msymbols}}{1 \text{ second}} \right)$$

The PM interference is 45 kHz.

In-Channel Amplitude Modulation (AM) Interference

Many signals are present in an integrated communications system including digital, baseband, IF, and RF signals. The close proximity of the integrated signals can lead to crosstalk between adjacent components resulting in unwanted signals at the signal output. PSA option 241 can help identify these interfering signals.

The interfering signal causes the amplitude or phase of the transmitted signal to be different each time the signal passes through the same state. AM interference causes a variation of the amplitude around the ideal symbol reference point.

The results shown were created with a amplitude modulation depth of 10% and a rate of 45 kHz.

Step 1. Use the I/Q polar constellation diagram first to identify the problem:

Press **Trace/View, I/Q Measured Polar Graph.**

Press **Display, I/Q Polar Type, Constellation.**

First note the order of magnitude difference in the magnitude and phase error. This indicates that some sort of unwanted amplitude modulation is the dominant error mode. Also note the variation of amplitude around the ideal symbol reference points.

Figure 2-71

I/Q Polar Constellation with AM Interference

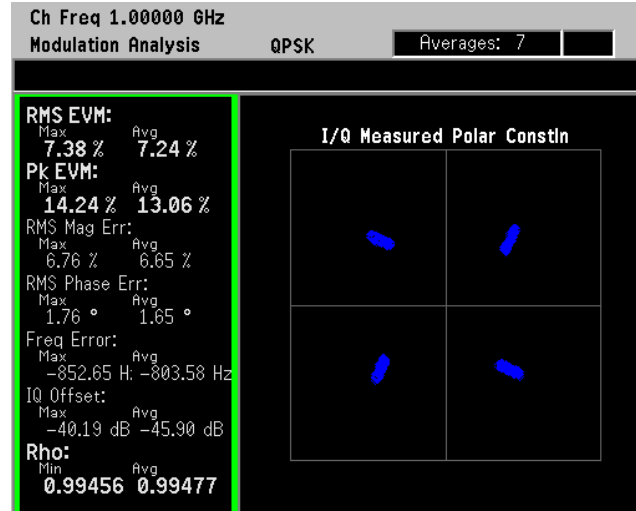

For a W-CDMA signal, AM interference appears as an aligning of the symbol decision points in the center of each quadrant, forming “lines” of dots. This line extends farther outward as the magnitude of the AM increases.

With the interference identified as AM interference, the next step is to identify the frequency and depth of the interfering AM signal.

Step 2. View the magnitude error graph:

Press **Trace/View, I/Q Error (Quad-View)**.
Press **Next Window** (until the Mag Error graph is selected), **Zoom**.

Step 3. Adjust the y-scale axis to view the waveform:

Press **AMPLITUDE Y Scale, Scale/Div** then adjust as necessary.

In this example the Scale/Div is set to 3 percent.

Figure 2-72

Magnitude Error Graph With PM Interference

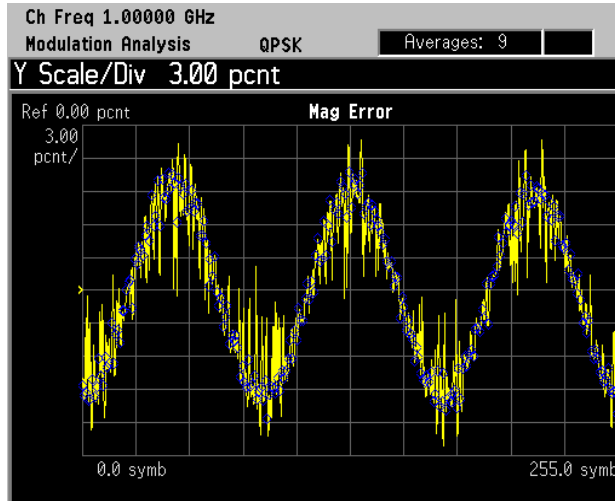

Equation 2-3 **Calculating AM Interference:**

$$\text{Frequency of AM interference} = \left(\frac{\text{No. of cycles}}{\text{symbol}} \right) \left(\frac{\text{No. of symbols}}{\text{second}} \right)$$

In our case we have 3 cycles per 256 symbols and 3.84 Msymbols per second.

Equation 2-4 **AM Interference Example Calculation**

$$\text{Frequency of AM interference} = \left(\frac{3 \text{ cycles}}{256 \text{ symbols}} \right) \left(\frac{3.84 \text{ Msymbols}}{1 \text{ second}} \right)$$

The AM interference is 45 kHz.

In-Channel Spurious Signal Interference

A tone or spur generated anywhere in the transmitter can interfere with the transmitted signal if it falls within the signal's bandwidth (see [Figure 2-73](#)). If the interfering tone falls outside of the signal's bandwidth, then it can cause interference with other channels or systems. In-channel interfering tones, however, are usually masked by the signal in the frequency domain. The spurious or interfering combine with the modulated signal and interact in a manner dependent on their relative phase relationships. The masked spur can be viewed by demodulating the signal.

The results shown were created with two ESGs. The first ESG is transmitting a W-CDMA signal at 1 GHz, -10 dBm and the second ESG is transmitting a C/W signal at 1.0005 GHz, -16 dBc.

Step 1. View the signal in the frequency domain to check for spurious signals within the signal's bandwidth:

Press **MEASURE, Spectrum (Freq Domain)**.

If the spur is not visible, try using a narrower resolution bandwidth with more averaging.

Step 2. Reduce the RBW and increase averaging to help view the spur:

Press **Meas Setup, Res BW, 30, kHz**.

Press **Meas Setup, Average, Avg Number, 100, Enter**.

Figure 2-73 Spectrum Display Showing In-Channel Spurious Interference

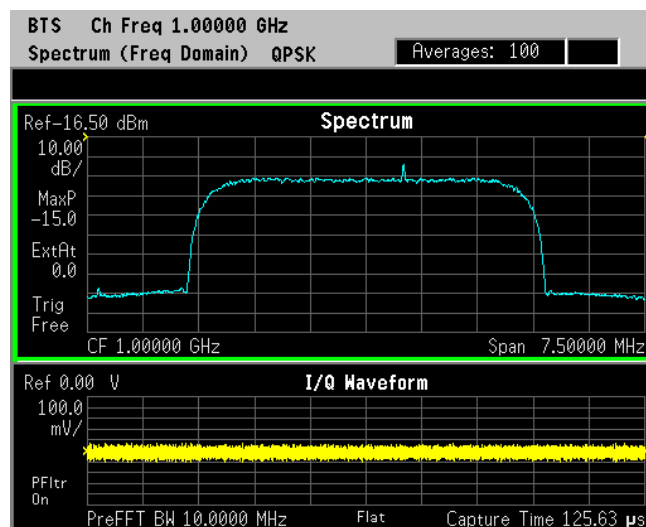

Step 3. Use the I/Q polar constellation diagram to help identify the problem:

Press **MEASURE, Modulation Analysis**.

Press **Trace/View, I/Q Measured Polar Graph**.

Press **Display, I/Q Polar Type, Constellation**.

Figure 2-74 I/Q Polar Constellation with Spurious Interference at -16 dBc

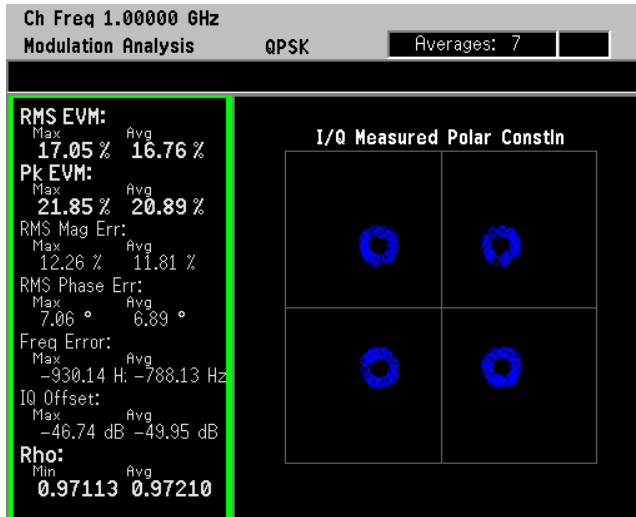

An in-channel spurious signal appears as ring-shaped groupings at the modulation symbol decision points in the I/Q polar constellation graph. This indicates the presence of an additional vector phasor rotating about the end of the magnitude vector, effecting the placement of the symbols at the decision points. This rotation is caused by a time-varying signal impressed upon the modulation. The ring diameter increases as the magnitude of the spur increases.

Figure 2-75 shows the same interfering signal but with a decreased amplitude of -24 dBc. The characteristic ring shape can still be seen.

Figure 2-75 I/Q Polar Constellation with Spurious Interference at -24 dBc

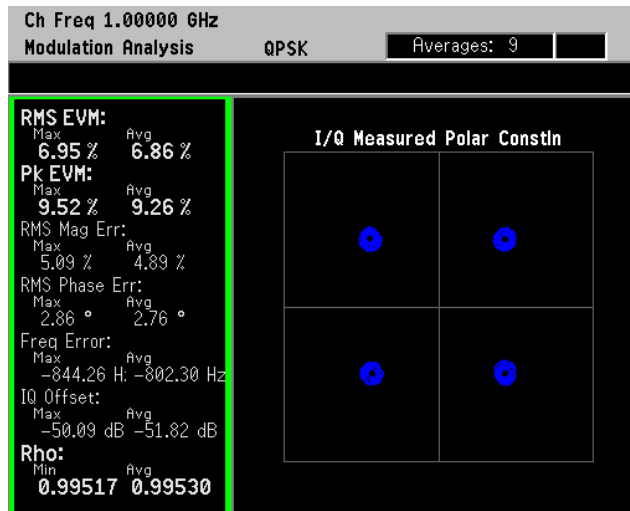

Baseband Filtering Errors

Filtering errors are among the most common in digital communication design. Typical filter errors can be due to errors in filter alpha, wrong filter shape, or incorrect filter coefficients. The result is increased inter-symbol interference. Lower peak overshoot is also caused by signal compression, which can indicate that an amplifier stage is being overdriven.

Alpha defines the sharpness of the filter roll-off. The lower the alpha, the sharper the filter is in the frequency domain and the higher the overshoot in the time domain. Conversely, the larger the alpha, the smaller the overshoot is in the time domain.

The I/Q measured polar vector diagram gives the first indication of baseband filtering errors. The smaller overshoots due to an increased alpha is shown by the trajectories between the symbol points. This reduces the required peak power and reduces the power requirements of the transmitter.

Step 1. Use a measurement filter alpha (α) of 0.22, the correct alpha value for a W-CDMA signal:

Press **Mode Setup, Radio, Radio Standard, WCDMA.**
Press **Trace/View, I/Q Measured Polar Vector.**

The display should look similar to [Figure 2-76](#) (left-side).

Step 2. To contrast filter alpha values use a filter value of 1:

Press **Meas Setup, Demod, Alpha/BT, 1, Enter.**

Observe in [Figure 2-76](#) (right-side) that there are smaller overshoots in the trajectories between the symbol points (item 1) due to the increased alpha. This limits the required peak power and reduces the transmitter power requirements. Item 2 shows spreading of the symbol points due to the increased EVM (item 3.)

Figure 2-76 I/Q Measured Polar Vector Diagram of a W-CDMA Signal: (Left - Alpha of 0.22, Right - Alpha of 1.0)

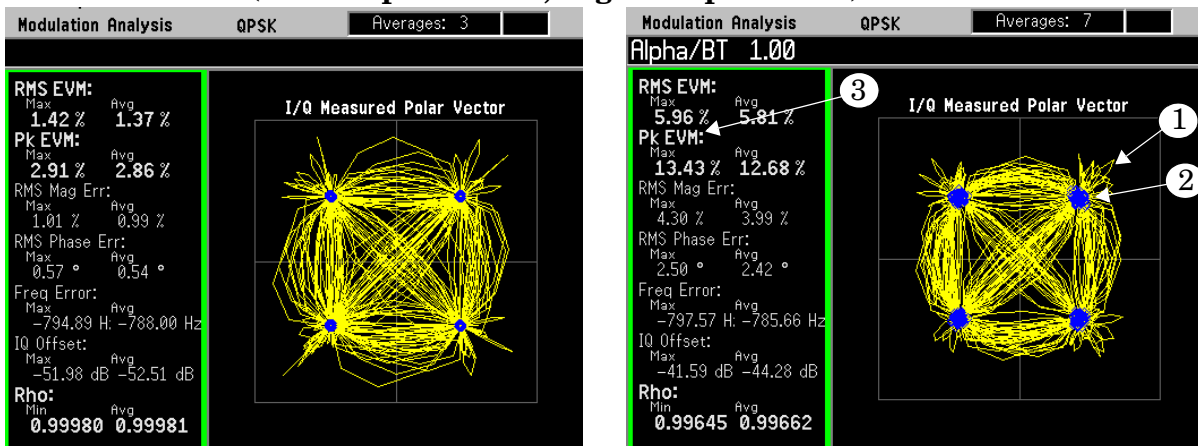

Step 3. Check the EVM versus symbol (time) display with a correct alpha value of 0.22 for W-CDMA:

Press **Meas Setup, Demod, Alpha/BT, 0.22, Enter.**

Press **Trace/View, I/Q Error (Quad-View).**

Press **Next Window, Next Window** (or until the EVM graph is the current selection), **Zoom.**

Step 4. Set an appropriate x-scale and y-scale to compare the correct alpha value, 0.22, versus an alpha value of 1.

Press **AMPLITUDE Y Scale, Scale/Div, 6, %.**

Press **SPAN X Scale, Scale/Div, 1, Symbols.**

The display should look similar to [Figure 2-76](#). Notice the uniform level of the EVM symbol-to-symbol.

Step 5. Change the filter alpha to 1:

Press **Meas Setup, Demod, Alpha/BT, 1, Enter.**

Notice in [Figure 2-77](#) (right-side) that the symbol locations have a small EVM but the transition from symbol-to-symbol is much larger resulting in incorrect transitions.

Figure 2-77 EVM versus Time: (Left - Alpha of 0.22, Right - Alpha of 1.0)

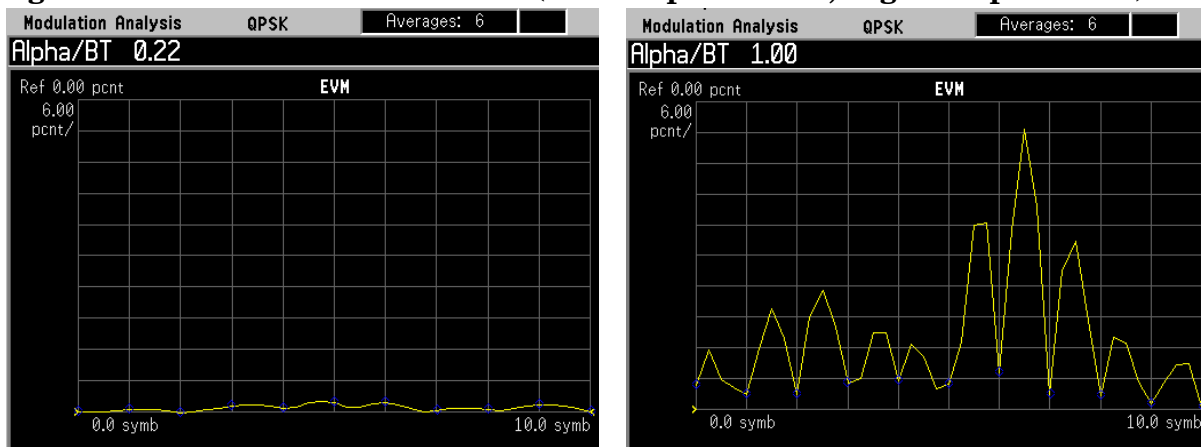

Symbol Rate Error

Small deviations in the symbol clock can result in significant modulation errors. Even a small error in symbol rate causes a large increase in peak EVM, and is indicated by a spreading of the symbol decision points.

Large symbol rate errors prevents the receiver from demodulating the signal. The modulation analysis personality is most useful in troubleshooting small symbol rate errors. To troubleshoot circuits with large symbol rate errors, try looking at the signal's channel bandwidth. Measuring channel bandwidth allows you to make an approximation of the symbol rate.

In this example the chip rate (modulation rate) of the transmitter (ESG) is set to 3.8415 Mcps to demonstrate a symbol rate error. Note that the correct W-CDMA symbol rate is 3.84 Mcps.

Step 1. Use the I/Q polar constellation diagram to identify symbol rate errors:

Press **Trace/View, I/Q Measured Polar Graph.**

Press **Display, I/Q Polar Type, Constellation.**

Figure 2-78 Symbol Rate Error (Left - 3.84 Mcps, Right - 3.8415 Mcps)

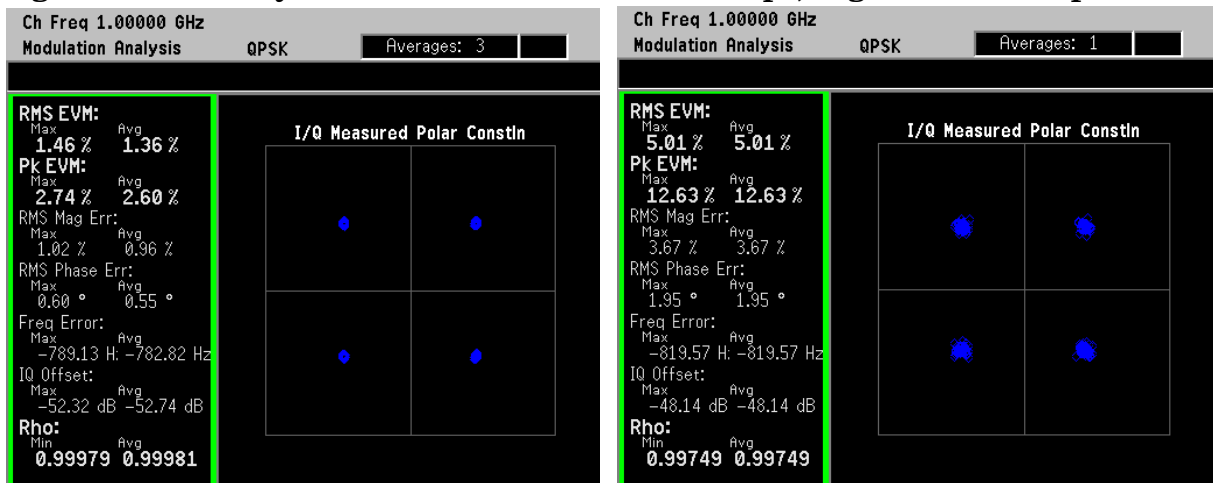

Note the spreading of the symbol decision points and large values of EVM in [Figure 2-78](#) (right-side).

Step 2. Next view the EVM versus time graph:

Press **Trace/View, I/Q Error (Quad-View).**

Press **Next Window, Next Window** (or until the EVM graph is the current selection), **Zoom.**

Figure 2-79

EVM vs Time Display Showing Symbol Rate Error

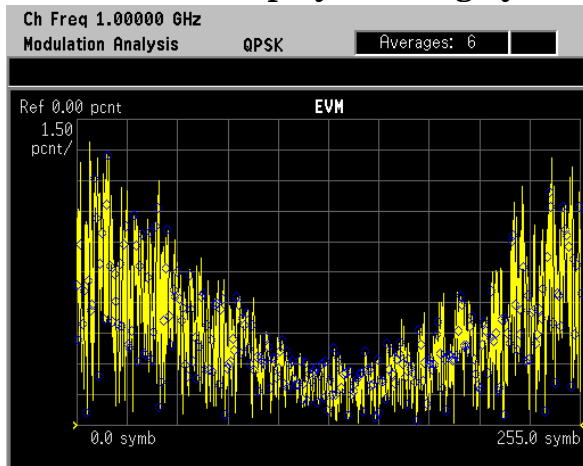

Figure 2-79 shows the EVM versus time graph. The characteristic “V” shape is caused by the demodulator aligning the expected symbol clock rate with the clock rate of the signal, for best fit at the midpoint of the trace. The differences in the two clocks show increasing “slip,” or deviation further from the trace center. In other words, at one arbitrary reference sample, the signal is sampled correctly. Since the symbol rate is skewed, any other sample in the positive or negative direction is slightly off in time. This causes an error which increases linearly in time.

To correct the symbol rate error, you can either adjust the symbol rate of your device or adjust the symbol rate of the demodulation parameters in Option 241 until the V-shape flattens out.

Signal Compression

Compression occurs when the instantaneous power levels are too high, driving the amplifier into saturation. For digitally-modulated signals, compression causes clipping and distortion, which may result in a loss of signal transmission efficiency and cause interference with other channels.

Clipping causes a peak-to-average ratio reduction, and a CCDF curve shows lower probabilities of reaching large peak-to-average ratios. In the modulation analysis personality, signal compression can be identified in the constellation diagram by a shift in the detection-decision points. The ratio of the peak EVM is 3 times or more than that of the RMS EVM.

The results shown were created with an ESG transmitting a W-CDMA signal at 1 GHz, -10 dBm with clipping applied to the signal.

Step 1. Use the I/Q polar constellation diagram first to identify the problem:

Press **Trace/View, I/Q Measured Polar Graph.**

Press **Display, I/Q Polar Type, Constellation.**

First note the order of magnitude difference in the peak EVM versus the RMS EVM. This indicates the signal has a high peak-to-average ratio. Also note the characteristic shift in the detection-decision points. The shift of constellation points in [Figure 2-80](#) is common for a compressed signal.

Figure 2-80 I/Q Polar Constellation with Signal Compression

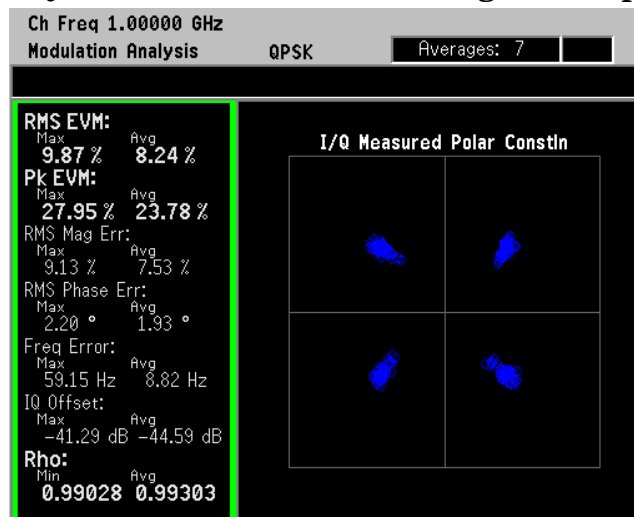

SCPI Programming a Modulation Measurement

This example uses SCPI programming commands to return scalar measurement results for a 16QAM signal.

Action	SCPI
Preset the analyzer and select the digital modulation mode.	*RST INST:SEL DMODULATION
Set the Radio Standards for a 16QAM signal with a 1 MHz symbol rate, the filter alpha = 0.22, with root Nyquist filtering.	RADio:STANdard:MODUlation QAM16 RADio:STANdard:SRATe 1MHz RADio:STANdard:ALPHa 0.22 RADio:STANdard:FILTer:MEASurement RNYQ RADio:STANdard:FILTer:REFerence NY
Select the number of sample data points.	EVM:SWEep:POINts 256
Select the type of EVM reference calculation.	EVM:CMODE MAX
Turn off Amplitude Droop Compensation	EVM:ADRoop:COMPensation OFF
Set the measurement to sync on a specific bit pattern in the signal. Send the hexadecimal bit pattern, the sync offset, and a search length.	EVM:SYNC:SOURce SWOR EVM:SYNC:SWORd:PATtern 1F4A EVM:SYNC:SWORd:OFFSet 10 EVM:SYNC:SLENgth 2ms
Turn on averaging and set the average count.	EVM:AVERAge ON EVM:AVERAge:COUNT 100
Send query to return the EVM scalar measurement results.	READ:EVM?

Interpreting Error Codes

During the execution of your measurement you may encounter problems which generate error codes. Reference to the following common errors may be helpful.

If **Err** is shown in the annunciator bar, press the **System**, **Show Errors** hard and soft keys to read the detailed error information.

- **Measurement Instability - Low Input Signal Level**

If the input signal level is too low to make a valid measurement no code domain power will be displayed in the **Power** graph window. In this situation, no error message can be displayed to indicate the nature of the fault. If you cannot increase the power into the tester, you need to increase the input sensitivity by adjusting the **ADC** range.

Press **Meas Setup**, **More (1 of 3)**, **More (2 of 3)**, **Advanced**, **ADC Range**, and then **Manual** keys. Increase the setting from the -6 dB (for E4406A) or **None** (for PSA) default to 6 dB, for example. Another option is to use the **Auto** setting (the **Auto** setting is not used as the default to improve measurement speed).

Press **Restart** to make another measurement and observe the results. Re-adjust the **ADC** as necessary to obtain a valid measurement.

- **Error Code 16 “Input overload”**

This error means that your measurement has erroneous results due to the excessive input power level. To correct this condition, the input signal level must be reduced by using the internal and/or external attenuators.

Press the **Mode Setup**, **Input**, **Input Atten** keys to enter an attenuation value to reduce the transmitted power from the **MS**. This allowable range is up to 40 dB.

If you want to attenuate more than 40 dB, connect your external attenuator between the **RF INPUT** port and the **DUT**. Be sure to add its attenuation value to the readings of the measurement result.

To automate this calculation, press the **Mode Setup**, **Input**, **Ext Atten** keys to enter the additional attenuation value. The allowable range is up to 100 dB. The power readings of the measurement will take into account the external attenuation value.

- **Error Code 601 “Signal too noisy”**

This error means that your input signal is too noisy to capture the correct **I/Q** components. To make a more stable measurement the trigger source may need to be set to **Frame**, for example.

- **Error Code 604 “Can not correlate to input signal”**

This error means that the tester has failed to find any active channels in the input signal as specified. To improve the correlation some critical parameter needs to be adjusted, like the input signal level or scramble code, for example.

For more details consult the chapter in this book dedicated to the measurement in question, or see the “Instrument Messages and Functional Tests” manual.

3 Front-Panel Key and SCPI Command Reference

This chapter provides detailed descriptions of the front-panel function keys and the associated SCPI commands and screens used to set up and make Flexible Digital Modulation Analysis measurements.

3.1 Instrument Front Panel Highlights

The most commonly used function keys on the PSA front panels are located as shown in the illustrations below. The operation of the keys is briefly explained on the following page. Refer to your User's Guide for complete details on all keys.

Figure 3-1 Selected PSA Series Front Panel Feature Locations

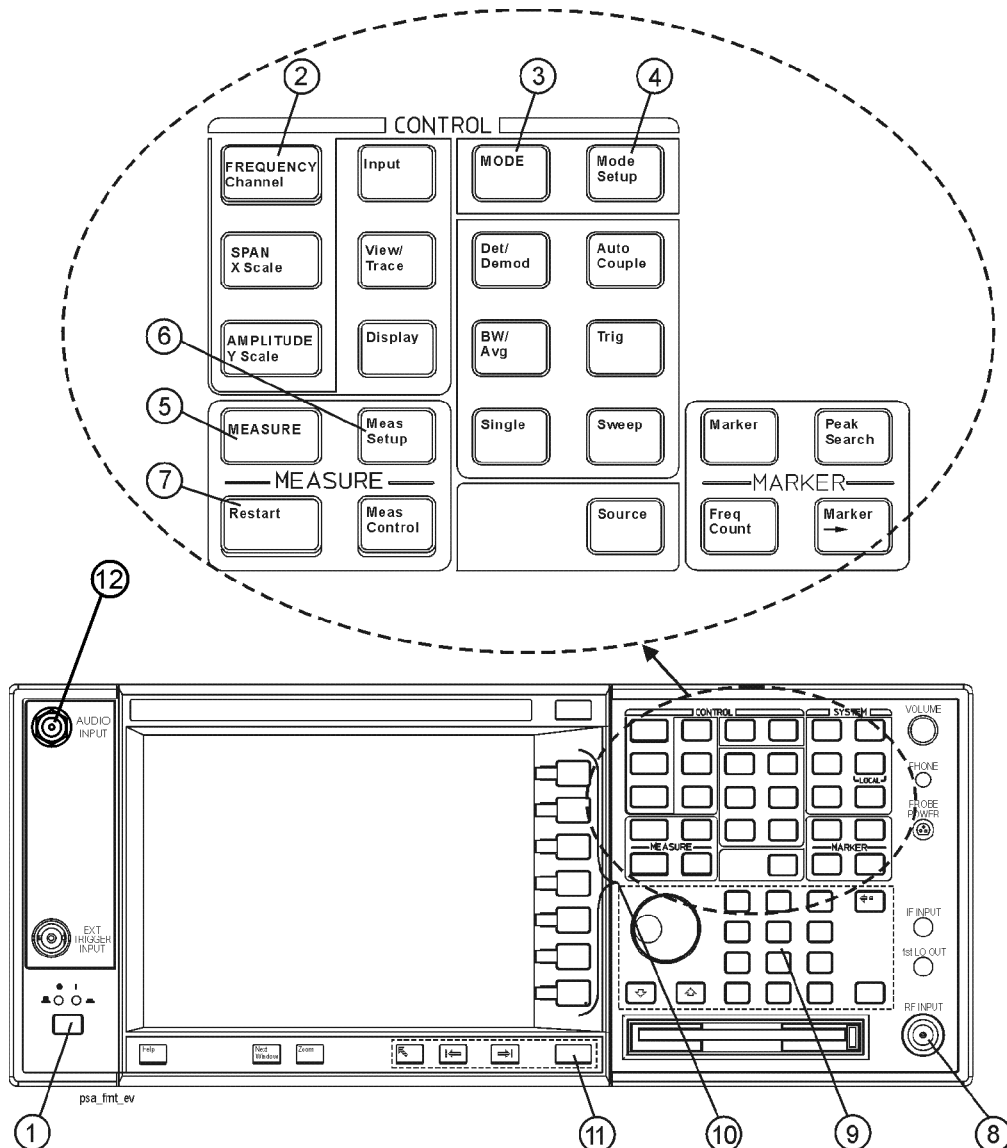

3.1.1 Selected PSA Front-Panel Features

1. The **On/Off** switch toggles the AC Line power between On and Standby. A green LED will light when the instrument is On. When energized in the standby mode, a yellow LED is lit above the switch.
2. **FREQUENCY Channel** accesses a key menu to set the analyzer center frequency in units of Hz, kHz, MHz, or GHz, or by channel number. These parameters apply to all measurements in the current mode.
3. **MODE** accesses a key menu to select one of the measurement personalities installed in the instrument. Each mode is independent from all other modes.
4. **Mode Setup** accesses a key menu that sets parameters specific to the current mode and can affect all measurements within that mode.
5. **MEASURE** accesses a display key menu to initiate one of the various measurements that are specific to the current mode.
6. **Meas Setup** accesses the menus of test parameters that are specific to the current measurement.
7. **Restart** causes a measurement to start again from the initial process according to the current measurement setup parameters.
8. **RF INPUT** port: Type N connector for the E4406A VSA and E4443A, E4445A, and E4440A PSAs. It is a 2.4 mm connector on the E4446A and E4448A PSAs and a 3.5 mm connector on all PSAs with Opt BAB. The maximum input power level is shown next to the port.
9. The **Data Entry** keypad is used to enter numeric values. Keypad entries are displayed in the active function area of the screen and become valid for the current measurement upon pressing the **Enter** key or selecting a unit of measurement, depending on the parameter.
10. The Display Menu keys allow you either to activate a feature or to access a more detailed sub-menu. An arrow on the right side of a softkey label indicates that the key has a further selection menu. The active menu key is highlighted, however, grayed-out keys are currently unavailable for use or only show information. If a menu has multiple pages, successive pages are accessed by pressing the **More** key located at the bottom of the menu.
11. **Return** allows you to exit the current menu and display the previous menu. If you are on the first page of a multi-page menu (a menu with **(1 of 3)** for example), the **Return** key will exit from that menu. When you activate another measurement, the return list is cleared. The **Return** key will not return you to a previously activated mode, nor will it alter any values you have entered in previous menus.
12. **BNC Audio Input** (PSA Option 233 Measuring Receiver only) provides a 100 kOhm input for audio measurements. The frequency range is 20 Hz to 250 kHz. The safe input level is 7 Vrms or 20 V DC.

3.2 Front-Panel Keys

NOTE Only front-panel keys affected by selecting the Digital Modulation mode are described here. For a complete description of all front panel keys see the PSA Series User's Guide.

3.2.1 Det/Demod

Different key menus are displayed for this front-panel key depending on the selected mode. When **Mode**, **Digital Modulation**, and **MEASURE, Modulation Analysis** has been selected, the key menu for Det/Demod can be accessed using the following methods.

- Pressing this front-panel key
- Pressing Mode Setup
- Pressing Meas Setup

The key description and remote command information for this key menu is located in [“Meas Setup” on page 150](#) of this chapter.

NOTE When selecting a mode other than Digital Modulation, refer to the particular mode's reference manual for more information about the keys unique to that mode.

3.2.2 FREQUENCY Channel

Displays the menu of frequency functions.

3.2.2.1 Center Frequency

Activates the function that sets the center of the desired RF channel to be measured.

Key Path: **FREQUENCY Channel**
 State saved: Saved in instrument state.

Factory Preset:

Model:	Center Frequency:
E4440A	1.0 GHz
E4443A	1.0 GHz
E4445A	1.0 GHz
E4446A	1.0 GHz
E4447A	1.0 GHz

E4448A 1.0 GHz

Range:

Model: Frequency Range with Frequency Offset = 0:

E4440A	-100.0 MHz	to	26.0 GHz
E4443A	-100.0 MHz	to	7.2 GHz
E4445A	-100.0 MHz	to	13.7 GHz
E4446A	-100.0 MHz	to	44.5 GHz
E4447A	-100.0 MHz	to	43.48 GHz
E4448A	1.0 kHz	to	51.0 GHz

Remote Command: [:SENSe]:FREQuency:CENTer <freq>
[:SENSe]:FREQuency:CENTer?

Example: :FREQ:CENT 2.0GHz
:FREQ:CENT?

3.2.2.2 CF Step

Allows you to set the center frequency step to shift the measurement segment, and to toggle the step function between **Auto** and **Man**. If set to **Auto**, the **CF Step** value automatically changes according to the selection of the radio standard.

Key Path	FREQUENCY Channel
Factory Preset	5 MHz
State Saved	Saved in instrument state.
Range	1.000 kHz to 1.00000 GHz with 1 kHz resolution.
Remote Command:	[:SENSe]:FREQuency:CENTer:STEP[:INCRement] <freq> [:SENSe]:FREQuency:CENTer:STEP[:INCRement]? [:SENSe]:FREQuency:CENTer:STEP:AUTO OFF ON 0 1 [:SENSe]:FREQuency:CENTer:STEP:AUTO?

Example: :FREQ:CENT:STEP:AUTO ON
:FREQ:CENT:STEP 500 MHz
:FREQ:CENT UP (increases the current center frequency value by 500 MHz)
:FREQ:CENT:STEP?
:FREQ:CENT:STEP:AUTO?

3.2.3 Input/Output

Displays the keys that control some of the signal inputs. You can also access this menu by selecting **Input** under the **Mode Setup** front-panel key.

3.2.3.1 Input Port

Displays a menu of input signal sources, the most common one being the front-panel RF Input port.

Key Path	Input/Output
Factory Preset	RF
State Saved	Saved in Instrument State
Remote Command:	[:SENSE] :FEED RF AREFERENCE EMIXER IFALIGN [:SENSE] :FEED?
Example	:FEED AREF

3.2.3.1.1 RF

Selects the front-panel RF Input port to be the analyzer signal input.

Key Path:	Input/Output, Input Port
State Saved:	Saved in Instrument State
Remote Command:	See “Input Port” on page 126
Example:	:FEED RF

3.2.3.1.2 Amptd Ref (f=50 MHz)

Selects the 50 MHz, -25 dBm internal amplitude reference as the input signal.

Key Path	Input/Output, Input Port
State Saved	Saved in Instrument State
Remote Command:	See “Input Port” on page 126
Example	:FEED AREF

3.2.3.1.3 IF Align

Selects the IF alignment signal. The RF path is switched to bring in the same alignment signal that is automatically switched to perform many alignments.

Key Path:	Input/Output, Input Port
State Saved:	Saved in Instrument State
Remote Command:	See “Input Port” on page 126
Example:	:FEED IFAL

3.2.3.2 Microwave Preselector

Selects whether the instrument uses a preselected or unpreselected input path. When this is ON, the preselected path is used by the RF section. When OFF, the unpreselected path is utilized. If opt.123 is not installed in the instrument, this key is NOT displayed in the **Input** menu and it remains ON.

Key Path	Input/Output
Preset	OFF
State Saved	Saved in instrument state.
Range	Off On
Remote Command:	<code>[:SENSe] :POWer [:RF] :MW:PRESelector [:STATe] OFF ON 0 1</code> <code>[:SENSe] :POWer [:RF] :MW:PRESelector [:STATe] ?</code>
Example	<code>:SENS:POW:MW:PRES ON</code> <code>:POW:MW:PRES?</code>

3.2.3.3 Input Atten

Allows you to control the internal input attenuator setting. The **Input Atten** key shows the actual hardware value that is used for the current measurement. If more than one input attenuator value is used in a single measurement, the value used at the carrier frequency will be displayed.

Key Path	Input/Output
Factory Preset	6 dB
State Saved	Saved in instrument state.
Range	0 to 70 dB
Default terminator	dB
Remote Command:	<code>[:SENSe] :POWer [:RF] :ATTenuation <rel_power></code> <code>[:SENSe] :POWer [:RF] :ATTenuation?</code>
Example	<code>:POW:ATT 10 dB</code>

3.2.3.4 Ext RF Atten

Accesses the device key menu that allows you to enter the external attenuation values. Both of the Ext Atten settings are coupled together with the RF Input Range setting, however, pressing **Ext Atten** does not switch the **RF Input Range** key to **Man**. This allows the instrument to display the measurement results referenced to the output of the UUT. There is no remote command for this function.

Key Path:	Input/Output
-----------	---------------------

Front-Panel Keys

3.2.3.4.1 MS

Sets an external attenuation value for MS tests. The range is -100.00 to +100.00 dB with 0.01 dB resolution

Key Path:	Input/Output, Ext RF Atten
Factory Preset	0 dB
State Saved	Yes
Range	-100 to 100
Default terminator	dB
Remote Command:	<code>[:SENSe] :CORRection:MS: [:RF] :LOSS <real></code> <code>[:SENSe] :CORRection:MS: [:RF] :LOSS?</code>
Example	<code>:CORR:MS:LOSS 10 dB</code>

3.2.3.4.2 BTS

Sets an external attenuation value for BTS tests. The range is -100.00 to +100.00 dB with 0.01 dB resolution.

Key Path:	Input/Output, Ext RF Atten
Factory Preset	0 dB
State Saved	Yes
Range	-100 to 100
Default terminator	dB
Remote Command:	<code>[:SENSe] :CORRection:BTS: [:RF] :LOSS <real></code> <code>[:SENSe] :CORRection:BTS: [:RF] :LOSS?</code>
Example	<code>:CORR:BTS:LOSS 20 dB</code>

3.2.3.5 Internal Preamp

Toggles the internal Preamp on and off. This key is active only when option 1DS is installed.

Key Path	Input/Output, More
Factory Preset	OFF
State Saved	Saved in instrument state.
Range	Off On
Remote Command	<code>[:SENSe] :POWer:GAIN:STATe] OFF ON 0 1</code> <code>[:SENSe] :POWer:GAIN:STATe] ?</code>
Example	<code>:POW:GAIN:STAT ON</code> <code>POW:GAIN:STAT?</code>

3.2.4 Meas Control

These functions allow you to pause and resume the currently selected measurement and to select between continuous or single measurements.

3.2.4.1 Restart

Press this key to repeat the current measurement from the beginning, while retaining the current measurement settings. This is equivalent to the **Restart** front-panel key.

Key Path:	Meas Control
Remote Command:	:INITiate:REStart
Remote Command Notes:	This command is equivalent to sending an :ABORt command followed by an :INITiate[:IMMediate] command.
Example:	:INIT:REST

3.2.4.2 Measure

Press this key to toggle the measurement state between Single and Cont (continuous).

NOTE This key has a different function than the **MEASURE** front-panel key. When set to Single, the measurement will continue until it has reached the specified number of averages set by the average counter. When set to Cont, the measurement will run continuously and execute averaging according to the current average mode, either repeat or exponential.

Key Path	Meas Control
Factory Preset	Cont
State Saved	Saved in instrument state.
Remote Command:	:INITiate:CONTinuous OFF ON
Remote Command Notes:	When ON, at the completion of each trigger cycle, the trigger system immediately initiates another trigger cycle. When OFF, the trigger system remains in an “idle” state until CONTinuous is set to ON or an :INITiate[:IMMediate] command is received. On receiving the :INITiate[:IMMediate] command, it will go through a single trigger cycle, and then return to the “idle” state. The query INIT:CONT? returns 1 or 0. 1 is returned when the instrument is continuous triggering. 0 is returned when it is single triggering.
Example	:INIT:CONT OFF

3.2.4.3 Pause/Resume

Press this key to pause the current measurement until you reactivate the measurement. Once toggled, the label of the **Pause** key changes to read **Resume**. The **Resume** key, once pressed, continues the active measurement from the point at which it was paused.

Key Path: **Meas Control**

Remote Command: :INITiate:PAUSE
:INITiate:RESume

Example: :INIT:PAUS

3.2.5 MEASURE

Accesses the three measurements available with this measurement personality after selecting **MODE**, Digital Modulation.

Key Path: **Front-panel key**

3.2.5.1 Modulation Analysis

This measurement provides you with the ability to analyze digitally modulated signals.

Key Path: **MEASURE** (after selecting **MODE**, Digital Modulation)

3.2.5.2 Spectrum

This measurement provides you with the ability to analyze signals in the frequency domain. Refer to the key reference and programming commands chapters in the *PSA Basic Mode Guide* for information on using this measurement. For more information, see [“Spectrum \(Frequency Domain\) Measurements” on page 32](#).

3.2.5.3 Waveform

This measurement provides you with the ability to analyze signals in the time domain. Refer to the key reference and programming commands chapters in the *PSA Basic Mode Guide* for information on using this measurement. For more information, see [“Waveform \(Time Domain\) Measurements” on page 42](#).

3.2.6 Mode

Accesses any installed personality mode. The minimum set of available modes will be Spectrum Analysis, Basic, and Digital Modulation Analysis. This menu has additional entries if other personalities have been installed, for example GSM/EDGE Option 202 or cdmaOne Option BAC.

3.2.7 Instrument Selection by Name (Remote command only)

This remote command allows you to use SCPI to change from the current mode to digital modulation mode. This has the same effect as pressing the **Digital Modulation** softkey.

Key Path:	Mode
Remote Command:	:INSTrument [:SElect] SA BASIC DMODULATION :INSTrument [:SElect] ?
Remote Command Notes:	DMODULATION (for Digital Modulation Mode).
Example:	:INST DMODULATION :INST?

3.2.8 Instrument Selection by Number (Remote command only)

This remote command allows you to use SCPI to change from the current mode to digital modulation mode (Option 241). This has the same effect as pressing the **Digital Modulation** softkey.

Key Path:	Mode
Remote Command:	:INSTrument :NSElect 241 :INSTrument :NSElect ?
Example:	:INST:NSEL 241 :INST:NSEL?

3.2.9 Mode Setup

Accesses all menus that enable you to change parameters for the three available measurements: Modulation Analysis, Spectrum, and Waveform.

3.2.9.1 Radio

Accesses the device and radio standards menus.

Key Path:	Mode Setup
-----------	-------------------

3.2.9.1.1 Radio Std

Accesses the menu of radio standards. Selecting the radio standard allows the measurement personality software to setup the various parameters required to make a valid demodulation. The radio standards available are:

- WCDMA:
- cdmaOne
- cdma2000
- NADC
- EDGE (Points / Symbol is preset to 1 when EDGE is selected as Radio Standard.)

Front-Panel Keys

- GSM
- PDC
- PHS
- TETRA
- Bluetooth
- ZigBee 2450MHz
- VDL Mode3
- APCO25 Phase1

Key Path	Mode Setup, Radio
Factory Preset	WCDMA
State Saved	Saved in instrument state.
Dependencies/Couplings	Setting this parameter changes the following parameters: Demod Format, Symbol Rate, Meas Filter, Ref Filter, Burst Search Thres, Burst Search Length, Burst Length, Burst Sync, Sync Pattern
Remote Command	<code>[[:SENSe]:RADio:STANdard[:SElect] CDMA CDMA2K WCDMA NADC EDGE PDC TETRA GSM PHS BLUETOOTH ZigBee2450 VDLM3 APCO2 P1[:SENSe]:RADio:STANdard[:SElect]?</code>
Example	<code>:RAD:STAN CDMA</code> <code>:RAD:STAN?</code>

3.2.9.1.2 Device

Selecting **Device** enables you to toggle between base station (BTS) and mobile (MS). Some radio standards require different parameter settings for each device.

Key Path	Mode Setup, Radio
Factory Preset	BTS
State Saved	Saved in instrument state.
Range	BTS MS
Dependencies/Couplings	Setting this parameter causes changes to the following parameters: Demod Format, Symbol Rate, Meas Filter, Ref Filter, Burst Search Thres, Burst Search Length, Burst Length, Burst Sync, Sync Pattern
Remote Command	<code>[[:SENSe]:RADio:DEvIce BTS MS[:SENSe]:RADio:DEvIce?</code>
Example	<code>:RAD:DEV BTS</code> <code>:RAD:DEV?</code>

3.2.9.2 Input

Accesses the same keys available when you select Input/Output on the front panel. Refer to [“Input/Output” on page 126](#) for key descriptions and programming commands.

Key Path: **Mode Setup**

3.2.9.3 Trigger

Accesses the same keys available when you select Trig on the front panel. Refer to [“Trig” on page 133](#) for key descriptions and programming commands.

Key Path: **Mode Setup**

3.2.9.4 Demod

Accesses the same keys available when you select Det/Demod on the front panel. Refer to [“Det/Demod” on page 124](#) for key descriptions and programming commands.

Key Path: **Mode Setup**

3.2.9.5 Trig Setup Form

Accesses the trigger setup form. Use the front-panel arrow keys located beneath the display, to highlight the parameter you wish to specify. Use the front-panel alpha-numeric keypad or the up down arrow keys (located below the front-panel knob) to enter your desired setting. The units for each parameter are available in the key menu after you select the numeric values. For an example of how to use the Trig Setup Form, see [“Using the Waveform Measurement to Set Up Triggering \(for burst signals\)” on page 41](#).

Key Path: **Mode Setup**

3.2.10 Trig

Different key menus are displayed for this front-panel key depending on the selected mode. When **Mode, Digital Modulation** has been selected, the key menu for Trig can be accessed using the following methods.

- Pressing this front-panel key
- Pressing Mode Setup

NOTE When selecting a mode other than Digital Modulation, refer to the particular mode's reference manual for more information about the keys unique to that mode.

3.2.10.1 RF Burst

Accesses the parameters that modify the steps used to initiate a trigger for a bursted signal.

Key Path: **Trig**

3.2.10.1.1 Delay

Sets the trigger delay when using the RF burst (wideband) trigger.

Key Path	Mode Setup, Trigger, RF Burst
Factory Preset	0.000000000
State Saved	Saved in instrument state.
Range	-0.100 to 0.500
Default terminator	seconds
Remote Command:	:TRIGger[:SEquence]:RFBurst:DELay <time> :TRIGger[:SEquence]:RFBurst:DELay?
Example	:TRIG:SEQ:RFB:DEL 0.015 :TRIG:RF:DEL?

3.2.10.1.2 Peak Level

Sets the trigger level when using the RF Burst (wideband) trigger. The value is relative to the peak of the signal. RF Burst is also known as RF Envelope.

Key Path	Mode Setup, Trigger, RF Burst
Factory Preset	- 6.0 dB
State Saved	Saved in instrument state.
Range	- 25 to 0.0
Default terminator	dB
Remote Command:	:TRIGger[:SEquence]:RFBurst:LEVel <rel_power> :TRIGger[:SEquence]:RFBurst:LEVel?
Example	:TRIG:SEQ:RFB:LEV - 15 :TRIG:RFB:LEV?

3.2.10.1.3 Slope

Sets the trigger slope when using the RF Burst (wideband) trigger.

Key Path	Mode Setup, Trigger, RF Burst
Factory Preset	Positive
State Saved	Saved in instrument state.

Range	Positive Negative
Remote Command:	:TRIGger[:SEquence]:RFBurst:SLOPe NEGative POSitive :TRIGger[:SEquence]:RFBurst:SLOPe?
Example	:TRIG:SEQ:RFB:SLOP NEG :TRIG:RFB:SLOP?

3.2.10.2 Video (IF Envlp)

Accesses a menu of parameters that define how you initiate a trigger for an IF Envelope.

Key Path: **Trig**

3.2.10.2.1 Delay

Sets the trigger delay of the IF (video) trigger (signal after the resolution BW filter).

Key Path	Mode Setup, Trigger, Video (IF Envlp)
Factory Preset	0.000000000 seconds
State Saved	Saved in instrument state.
Range	-0.100000000 to 0.500000000 seconds
Default Terminator	seconds
Remote Command	:TRIGger[:SEquence]:IF:DElAy <time> :TRIGger[:SEquence]:IF:DElAy?
Example	:TRIG:SEQ:IF:DEL 0.15 :TRIG:IF:DEL?

3.2.10.2.2 Level

Sets the trigger level when using the IF (video) trigger.

Key Path	Mode Setup, Trigger, Video (IF Envlp)
Factory Preset	- 6.0 dBm
State Saved	Saved in instrument state.
Range	- 200.0 to 50.0 dBm
Default Terminator	dBm
Remote Command	:TRIGger[:SEquence]:IF:LEVel <ampl> :TRIGger[:SEquence]:IF:LEVel?
Example	:TRIG:SEQ:IF:LEV -15 :TRIG:IF:LEV?

Front-Panel Keys

3.2.10.2.3 Slope

Sets the trigger slope to either NEGative or POSitive when using the IF (video) trigger.

Key Path	Mode Setup, Trigger, Video (IF Envlp)
Factory Preset	Positive
State Saved	Saved in instrument state.
Range	Positive or Negative
Remote Command	:TRIGger[:SEQuence]:IF:SLOPe NEGative POSitive :TRIGger[:SEQuence]:IF:SLOPe?
Example	:TRIG:SEQ:IF:SLOP NEG :TRIG:IF:SLOP?

3.2.10.3 Ext Front

Accesses the key menu of parameters that define how you trigger from an external source connected to the instrument front panel.

Key Path: **Trig**

3.2.10.3.1 Delay

Sets the trigger delay when using an external trigger. Set the trigger value to zero (0) seconds to turn off the delay.

NOTE EXT or EXT1 is the front-panel trigger input.
EXT2 is the rear-panel trigger input.

Key Path	Mode Setup, Trigger, Ext Front (or Ext Rear)
Factory Preset	0.000000000 Seconds
State Saved	Saved in instrument state.
Range	-0.100000000 to 0.500000000 Seconds
Default Terminator	Seconds
Remote Command	:TRIGger[:SEQuence]:EXTernal[1] 2:DELAy <time> :TRIGger[:SEQuence]:EXTernal[1] 2:DELAy?
Example	:TRIG:EXT2:DEL 0.2 :TRIG:EXT:DEL?

3.2.10.3.2 Level

Sets the trigger level when using an external trigger input.

NOTE EXT or EXT1 is the front-panel trigger input
 EXT2 is the rear-panel trigger input

Key Path	Mode Setup, Trigger, Ext Front (or Ext Rear)
Factory Preset	2.0 Voltage
State Saved	Saved in instrument state.
Range	- 5.00 to +5.00 V
Default Terminator	Voltage
Remote Command	:TRIGger[:SEQuence]:EXTernal[1] 2:LEVel <voltage> :TRIGger[:SEQuence]:EXTernal[1] 2:LEVel?
Example	:TRIG:EXT2:LEV 4.5 :TRIG:EXT:LEV?

3.2.10.3.3 Slope

Sets the trigger slope of an external trigger input to either NEGative or POSitive.

Key Path	Mode Setup, Trigger, Ext Front (or Ext Rear)
Factory Preset	Positive
State Saved	Saved in instrument state.
Range	Positive or Negative
Remote Command	:TRIGger[:SEQuence]:EXTernal[1] 2:SLOPe NEGative POSitive :TRIGger[:SEQuence]:EXTernal[1] 2:SLOPe?
Example	:TRIG:SEQ:EXT2:SLOP NEGative :TRIG:EXT:SLOP?

3.2.10.4 Ext Rear

Accesses a menu of parameters that define how you trigger from an external source connected to the instrument rear panel.

Key Path: **Trig**

Front-Panel Keys

3.2.10.4.1 Trigger Holdoff

Sets a value of the holdoff time between triggers. After a trigger, another trigger will not be allowed until the holdoff time expires. This parameter affects all trigger sources.

Key Path	Mode Setup, Trigger
Factory Preset	0.000000000 Seconds
State Saved	Saved in instrument state.
Range	0.000000000 to 0.500000000 Seconds
Default Terminator	Seconds
Remote Command	:TRIGger[:SEQuence]:HOLDoff <time> :TRIGger[:SEQuence]:HOLDoff?
Example	:TRIG:SEQ:HOLD 0.033 :TRIG:HOLD?

3.2.10.4.2 AutoTrig

Allows you to specify a time for a trigger time-out and toggle the auto trigger function between On and Off. If no trigger occurs by the specified time, a trigger is automatically generated.

Key Path	Mode Setup, Trigger
Factory Preset	0.1, On Seconds
State Saved	Saved in instrument state.
Range	0.001 to 1000 Seconds
Default Terminator	Seconds
Remote Command	:TRIGger[:SEQuence]:AUTO[:TIME] <time> :TRIGger[:SEQuence]:AUTO[:TIME]? :TRIGger[:SEQuence]:AUTO:STATe ON OFF 1 0 :TRIGger[:SEQuence]:AUTO:STATe?
Example	:TRIG:AUTO 0.5 :TRIG:AUTO:STAT OFF

3.2.10.5 Frame Timer

Allows you to access the menu to manually control the frame timer.

Key Path:	Trig
-----------	-------------

3.2.10.5.1 Period

Sets the frame period when using the external frame timer trigger. If the traffic rate is changed, the value of the frame period is initialized to the preset value.

Key Path	Mode Setup, Trigger, Frame Timer
Factory Preset	0.01 Seconds
State Saved	Saved in instrument state.
Range	0.000000000 to 0.559 Seconds
Default Terminator	Seconds
Remote Command	:TRIGger[:SEQuence]:FRAMe:PERiod <time> :TRIGger[:SEQuence]:FRAMe:PERiod?
Example	:TRIG:FRAM:PER 0.15 :TRIG:FRAM:PER?

3.2.10.5.2 Offset

Allows you to set the offset of the frame clock. The range is 0.000 to 10.00 s with 100 ns resolution over 1.000 μ s range.

Key Path	Mode Setup, Trigger, Frame Timer
Factory Preset	0.000000000 Seconds
State Saved	Saved in instrument state.
Range	0 to 10 Seconds
Default Terminator	Seconds
Remote Command	:TRIGger[:SEQuence]:FRAMe:SYNCmode:OFFSet <time> :TRIGger[:SEQuence]:FRAMe:SYNCmode:OFFSet?
Example	:TRIG:FRAM:SYNC:OFFS 1.5 :TRIG:FRAM:SYNC:OFFS?

3.2.10.5.3 Reset Offset Display

Sets the offset display to 0.

Key Path:	Mode Setup, Trigger, Frame Timer
Factory Preset:	Off

Front-Panel Keys

3.2.10.5.4 Sync Source

Accesses a menu with source synchronization options.

Off – Allows you to turn the synchronizing source off for the asynchronous tests.

Ext Front – Allows you to select the external input signal from the front panel input port as the synchronizing source.

Ext Rear – Allows you to select the external input signal from the rear panel input port as the synchronizing source.

Key Path	Mode Setup, Trigger, Frame Timer
Factory Preset	Off
State Saved	Saved in instrument state.
Range	Off Ext Front Ext Rear
Remote Command	:TRIGger [:SEQuence] :FRAMe:SYNCmode OFF EXTFront EXTrear :TRIGger [:SEQuence] :FRAMe:SYNCmode?
Example	:TRIG:FRAM:SYNC EXTF

3.3 Modulation Analysis Measurement Keys

NOTE You must have selected **MEASURE, Modulation Analysis** to access these menus.

3.3.1 AMPLITUDE Y Scale

Displays the Amplitude menu keys. These functions control how data on the vertical (Y) axis is displayed, and control instrument settings that affect the vertical axis.

NOTE The Scale Coupling for the Y scale never changes the Ref Position setting and sets the Ref Value and the Scale/Div to make the entire trace data fit the width or height of the window.

Table 3-1 Y Scale Units and Default Settings

Window Name	Y Scale Unit	Y-Scale Defaults			
		Scale / Div	Ref Position	Ref Value	Scale Coupling
EVM	%	1.0	Bottom	0.0	On
Mag Error	%	1.0	Center	0.0	On
Phase Error	degree	1.0	Center	0.0	On
Numeric Results	N/A	N/A	N/A	N/A	N/A
IQ Measured Polar Vector, IQ Reference Vector	no unit	N/A	N/A	N/A	N/A
Eye I	no unit	0.25	Center	0.0	On
Eye Q	no unit	0.25	Center	0.0	On
FSK Error	% (Normalized), Hz (Absolute)	1.0	Center	0.0	On
FSK Measured	no unit (Normalized), Hz (Absolute)	1.0	Center	0.0	On
FSK Error Spectrum	dB% (Normalized), dBHz (Absolute)	1.0	Top	0.0	On

Table 3-1 Y Scale Units and Default Settings

Window Name	Y Scale Unit	Y-Scale Defaults			
		Scale / Div	Ref Position	Ref Value	Scale Coupling
Demod Bits	N/A	N/A	N/A	N/A	N/A
RF Spectrum	dBm	1.0	Top	0.0	On
EQ Channel Response Magnitude	no unit	1.0	Top	0.0	On
EQ Channel Response Phase	degree	1.0	Center	0.0	On
EQ Impulse Response	no unit	1.0	Center	0.0	On
Error Vector Spectrum	dB	1.0	Top	0.0	On

3.3.2 Y Scale / Div

Sets the vertical scale per division. Y Scale/Div can be set for trace displays located under the **Trace/View** menu. When Scale Coupling (default) is On, this value is automatically determined by the measurement results. When you set a value manually, Scale Coupling automatically changes to Off.

Restriction Default value is set by function and is determined by the referenced trace.

Key Path **AMPLITUDE Y Scale**

Factory Preset See “Y Scale Units and Default Settings” on page 141.

State Saved Saved in instrument state.

Unit/Termination See “Y Scale Units and Default Settings” on page 141.

Soft Key Label Scale / Div

Dependencies/Couplings Change of default value forces Y Scale Coupling off.

Remote Command :DISPlay:EVM[1] | 2 | 3 | 4 | 5 | 6 | 7 | 8 :WINDow [1] | 2 | 3 | 4 :TRACe:Y[:SCALe] : PDIVision <real>

:DISPlay:EVM[1] | 2 | 3 | 4 | 5 | 6 | 7 | 8 :WINDow [1] | 2 | 3 | 4 :TRACe:Y[:SCALe] : PDIVision?

Example :DISP:EVM3:WIND2:TRAC:Y:PDIV 276.4

:DISP:EVM3:WIND2:TRAC:Y:PDIV?

3.3.3 Y Ref Value

Set the vertical reference value. Ref in the upper left corner of the display indicates the current value. Since the Scale Coupling default is On, this value is automatically determined by the measurement results. When you set a value manually, Scale Coupling automatically changes to Off.

Key Path	AMPLITUDE Y Scale
Factory Preset	See “Y Scale Units and Default Settings” on page 141.
State Saved	Saved in instrument state.
Range	See “Y Scale Units and Default Settings” on page 141.
Unit/Termination	See “Y Scale Units and Default Settings” on page 141.
Dependencies/Couplings	Change of this forces Y Scale Coupling off.
Remote Command	:DISPlay:EVM[1] 2 3 4 5 6 7 8 : WINDow [1] 2 3 4 : TRACe:Y[:SCALe] :RLEVel <real> :DISPlay:EVM[1] 2 3 4 5 6 7 8 : WINDow [1] 2 3 4 : TRACe:Y[:SCALe] :RLEVel?
Example	:DISP:EVM3:WIND2:TRAC:Y:RLEV -27650 :DISP:EVM3:WIND2:TRAC:Y:RLEV?

3.3.4 Y Ref Position

Sets the reference position to Top, Ctr (center) or Bot (bottom).

Key Path	AMPLITUDE Y Scale
Factory Preset	Refer to "Y Scale Default Values and Units for Each Window View" Table
State Saved	Saved in instrument state.
Range	Top Ctr Bot
Dependencies/Couplings	Change of this forces Y Scale Coupling off.
Remote Command	:DISPlay:EVM[1] 2 3 4 5 6 7 8 : WINDow [1] 2 3 4 : TRACe:Y[:SCALe] :RPOSition TOP CENTer BOTTom :DISPlay:EVM[1] 2 3 4 5 6 7 8 : WINDow [1] 2 3 4 : TRACe:Y[:SCALe] :RPOSition?
Example	:DISPlay:EVM3:WIND2:TRAC:Y:RPOS TOP :DISP:EVM3:WIND2:TRAC:Y:RPOS?

3.3.5 Y Scale Coupling

Toggle the scale coupling function between On and Off. The default setting is On. Upon pressing the **Restart** front-panel key or **Restart** softkey under the Meas Control menu, this function automatically determines the scale per division and reference values based on the measurement results. When you set a value to either Scale/Div or Ref Value manually, Scale Coupling automatically changes to Off.

Key Path	AMPLITUDE Y Scale
Factory Preset	ON
State Saved	Saved in instrument state.
Range	Off On
Dependencies/Couplings	Turning this on sets Y Scale / Div and Y Scale Reference to appropriate values.
Remote Command	:DISPlay:EVM[1] 2 3 4 5 6 7 8 : WINDow [1] 2 3 4 : TRACe : Y [: SCALe] : COUPle 0 1 OFF ON :DISPlay:EVM[1] 2 3 4 5 6 7 8 : WINDow [1] 2 3 4 : TRACe : Y [: SCALe] : COUPle?
Example	:DISP:EVM3:WIND2:TRAC:Y:COUP ON :DISP:EVM3:WIND2:TRAC:Y:COUP?

3.3.6 Display

The Display parameters are not used to calculate modulation results but they are used to determine the results to display.

3.3.6.1 I/Q Points

Specify the total number of I/Q points displayed during each measurement interval in the I/Q Measured Polar Vector Graph and in the I and Q Eye diagrams.

Key Path	Display
Factory Preset	256 Symbols
State Saved	Saved in instrument state.
Range	1 to Meas Interval (Symbols)
Unit/Termination	Symbols
Dependencies/Couplings	Change of Meas Interval sets IQ Points to the same number as Meas Interval.
Remote Command	:DISPlay:EVM:IQPoints <integer> :DISPlay:EVM:IQPoints?

Example :DISP:EVM:IQP 256
 :DISP:EVM:IQP?

3.3.6.2 I/Q Points Offset

Specify an offset from the first I/Q point in the constellation and eye diagrams. If you choose to display only a subset of the I/Q points, this subset of displayed points is offset from the first I/Q point.

Key Path	Display
Factory Preset	0 Symbols
State Saved	Saved in instrument state.
Range	0 to (Meas Interval) – (IQ Points) Symbols
Unit/Termination	Symbols
Dependencies/Couplings	Change of Meas Interval sets IQ Points Offset 0.
Remote Command	:DISPlay:EVM:IQPoints:OFFSet <integer> :DISPlay:EVM:IQPoints:OFFSet?
Remote Command Notes	SCPI word EVM may accept sub-op code because X/Y scale parameters accept it, but it is ignored for this parameter and the behavior is same as the command without it.
Example	:DISP:EVM:IQP:OFFS 15 :DISP:EVM:IQP:OFFS?

3.3.6.3 Full Vector

When the **I/Q Points** value is less than **Meas Interval**, the non-selected portion of the I/Q vector is not displayed. When **Full Vector** is on, the trace of the hidden portion is displayed in grey.

Key Path	Display
Factory Preset	OFF
State Saved	Saved in instrument state.
Range	Off On
Dependencies/Couplings	This key does not appear when Demod Bits window is active.
Remote Command	:DISPlay:EVM:FVEctor[:STATe] OFF ON 0 1 :DISPlay:EVM:FVEctor[:STATe]?
Example	:DISP:EVM:FVEC ON :DISP:EVM:FVEC?

3.3.6.4 Points / Symbol

Sets the number of points displayed between symbols for demodulated data. Selecting **Points/Symbol** brings up a sub-menu giving you options of 1, 2, 4, 5 and 10 points per symbol. For example, if the value of **Points/Symbol** is 1, each display point corresponds to a symbol. If the value of **Points/Symbol** is 5, every 5th display point corresponds to a symbol - in this case, a vector diagram would show 4 display points between each symbol, with a yellow trace joining each of the points.

Key Path	Display
Factory Preset	4
State Saved	Saved in instrument state.
Range	1 2 4 5 10
Dependencies/Couplings	Only even numbers can be set when Modulation Format is OQPSK.
Remote Command	:DISPlay:EVM:PPSYmbol ONE TWO FOUR FIVE TEN :DISPlay:EVM:PPSYmbol?
Remote Command Notes	SCPI word EVM may accept sub-op code because the X/Y scale parameters accept it, but it is ignored for this parameter and the behavior is same as the command without it.
Example	:DISP:EVM:PPSY TWO :DISP:EVM:PPSY?

3.3.6.5 I/Q Polar Type

Select from one of the following polar display types:

Vec&Constln: Sets the view to display both the vector and constellation diagrams. Numeric results also appear on the left side of the screen.

Vector: Sets the view to display an I/Q polar vector diagram and numeric results.

Constellation: Sets the view to display numeric results and the constellation diagram.

Key Path	Display
Factory Preset	VCONstln
State Saved	Saved in instrument state.
Range	Vec & Constln Vector Constellation
Remote Command	:DISPlay:EVM:IQPTType VCONstln VECTor CONStln :DISPlay:EVM:IQPTType?
Example	:DISP:EVM:IQPT VCON :DISP:EVM:IQPT?

3.3.6.6 I/Q Rotation

Specify whether or not rotation is applied to the I/Q constellation display. The I/Q constellation can be rotated from 0 to 359.5 degrees. I/Q Rotation only effects the display, not any measurement parameters.

Key Path	Display
Factory Preset	45 Deg, OFF
State Saved	Saved in instrument state.
Range	0 to 359.5 Deg, None
Unit/Termination	Deg
Remote Command	:DISPlay:EVM:IQRotation <degree> :DISPlay:EVM:IQRotation? :DISPlay:EVM:IQRotation:STATe ON OFF 1 0 :DISPlay:EVM:IQRotation:STATe?
Example	:DISP:EVM:IQR 276.5 :DISP:EVM:IQR?

3.3.6.7 Prev Page

Shows the previous page of demod bits window.

Key Path:	Display
-----------	---------

3.3.6.8 Next Page

Shows the next page of demod bits window.

Key Path:	Display
-----------	---------

3.3.6.9 Scroll Up

Scrolls up the demod bits window by one line.

Key Path:	Display
-----------	---------

3.3.6.10 Scroll Down

Scrolls down the demod bits window by one line.

Key Path:	Display
-----------	---------

3.3.6.11 First Page

Shows the first page of demod bits window.

Key Path:	Display
-----------	---------

3.3.6.12 Last Page

Shows the last page of demod bits window.

Key Path: **Display**

3.3.6.13 Demod Bit Format

Toggles the demod bit format. The available choices are binary or hexadecimal formats.

Binary Format:

The symbol data bit format is binary and each character represents a binary digit. The number to the left of each row indicates the bit offset of the first bit in the row.

Hexadecimal Format:

The symbol data bit format is hexadecimal and each character represents a hexadecimal digit. The number to the left of each row indicate the symbol offset of the first symbol in the row

NOTE There must be at least 4 bits/symbol to use the hexadecimal format. Symbols that have less than 4 bits/symbol will only be displayed in binary format regardless of the Symbol Table Format setting.

This key function does not affect SCPI results returned.

Key Path: **Display**
Factory Preset: BINary
State Saved: Saved in instrument state.

3.3.7 Markers

Markers can be put on your displayed measurement data to supply information about specific points on the data. Some of the things that markers can be used to measure include: precise frequency at a point, minimum or maximum amplitude, and the difference in amplitude or frequency between two points. Make sure you select the desired trace for the marker using the MARKer:TRACe: command or by selecting a trace from the **Trace** menu (see below).

When using the marker commands you must specify the measurement in the SCPI command.

We recommend that you use the marker commands only on the current measurement. Many marker commands will return invalid results, when used on a measurement that is not current. (This is true for commands that do more than simply set or query an instrument parameter.) No error is reported for these invalid results.

You must make sure that the measurement is completed before trying to query the marker value. Using the MEASure or READ command, before the marker command, forces the measurement to complete before allowing the next command to be executed.

Each measurement has its own instrument state for marker parameters. Therefore, if you exit the measurement, the marker settings in each measurement are saved and are then recalled when you change back to that measurement.

3.3.7.1 Normal

When a marker is selected by the Select key, the default setting activates the selected marker to read the magnitude or phase error and/or the number of chips at the marker position on the selected trace. The Marker position is controlled by the front-panel knob, or by direct numerical entry. This key is also used to restore the Normal marker function to a marker that was previously used for another function, like Delta.

3.3.7.2 Delta

When a marker is selected by the Select key, this key invokes another marker (numbered in sequence) which remains in the position of the selected marker, allowing you to move the selected marker to bracket a portion of a trace. The differences in the magnitude or phase errors and the number of chips between the stationary and selected markers is displayed. Noise marker function is not available when using Delta markers.

3.3.7.3 Function

Displays the key menu to set the marker function to Band Power, Noise, or Off. The default setting is Off.

Key Path	Marker
Factory Preset	Off
State Saved	Saved in instrument state
Remote Command	:CALCulate:EVM:MARKer[1] 2 3 4:FUNctIon BPOwer NOISe OFF :CALCulate:EVM:MARKer[1] 2 3 4:FUNctIon?
Remote Command Notes	The marker must have already been assigned to a trace. Use :CALCulate:<measurement>:MARKer[1] 2 3 4:TRACe to assign a marker to a particular trace The keyword for the current measurement must be specified in the command. (Some examples include: SPECTrum, WAVeform)
Example	:CALC:SPEC:MARK:FUNC:NOISe :CALC:SPEC:MARK:FUNC?

3.3.7.4 Trace

Manual selection displays the key menu to select the type of trace you wish to view. The Remote Command selects the trace directly from the various types available.

Key Path	Marker
Factory Preset	EVM
State Saved	Saved in instrument state

Modulation Analysis Measurement Keys

Remote Command	:CALCulate:<measurement>:MARKer[1] 2 3 4:TRACe EVM MERRor PERRor EIRReal EIRImag ECRMagnitude ECRPhase EVSpectrum AEVSpectrum FERRor FESpectrum AFESpectrum FMEAsured DBITs RFSPpectrum ARFSpectrum :CALCulate:<measurement>:MARKer[1] 2 3 4:TRACe?
Remote Command Notes	The names of valid traces are dependent upon the selected measurement. See the range values for the available trace names. The trace name assignment is independent of the marker number. The keyword for the current measurement must be specified in the command. (Some examples include: SPECTrum, WAVeform)
Example	:CALC:EVM:MARK:TRACE DBIT :CALC:EVM:MARK2:TRACE?

3.3.7.5 Off

Turns off the selected marker.

Key Path	Marker , Then select Marker Normal or Marker On Off
Factory Preset	Off
State Saved	Saved in instrument state
Range	On Off
Remote Command	:CALCulate:EVM:MARKer[1] 2 3 4[:STATe] OFF ON 0 1
Remote Command Notes	The marker must have already been assigned to a trace. Use :CALCulate:<measurement>:MARKer[1] 2 3 4:TRACe to assign a marker to a particular trace. The keyword for the current measurement must be specified in the command. (Some examples include: SPECTrum, AREFERENCE, WAVeform)
Example	:CALC:EVM:MARK2 ON

3.3.7.6 Shape

Selects the shape of the selected marker. The available choices are: Diamond, Line, Square, and Cross,

3.3.7.7 Marker All Off

Sets all markers to Off.

3.3.8 Meas Setup

Displays the measurement setup menu for the digital modulation mode when the Modulation Analysis key has been selected in the Measure menu. There is no remote command for this function.

3.3.8.1 Average

Displays a menu to allow you to set up measurement averaging. There is no remote command for this function.

3.3.8.1.1 Avg Number

Set the number of N averages. Toggle averaging on or off.

Key Path:	Meas Setup
State Saved:	Saved in instrument state.
Factory Preset:	10, On
Range:	1 to 10000, OFF ON 0 1
Remote Command:	[:SENSe]:EVM:AVERage:COUNT <integer> [:SENSe]:EVM:AVERage:COUNT? [:SENSe]:EVM:AVERage[:STATe] OFF ON 0 1 [:SENSe]:EVM:AVERage[:STATe]?

Example:
 EVM:AVER:COUN 25
 EVM:AVER:COUN?
 EVM:AVER ON
 EVM:AVER?

3.3.8.1.2 Avg Mode

Toggle the averaging mode between Exp (exponential) and Repeat. This selection only effects on the averaging result after the number of N averages is reached. The N is set using the **Avg Number** key.

Exponential averaging: When Measure is set to Cont, data acquisition will continue indefinitely. Exponential averaging is used with a weighting factor of N (the displayed count of averages stops at N). Exponential averaging weights new data more heavily than old data, which allows tracking of slow-changing signals. The weighting factor N is set using the **Avg Number** key.

Repeat averaging: When Measure is set to Cont, data acquisition will continue indefinitely. After the number of N averages is reached, all previous result data is cleared and the average count displayed is set back to 1. This is equivalent to being in Measure Single and pressing the **Restart** key each time the single measurement finishes.

Key Path:	Meas Setup
State Saved:	Saved in instrument state.
Factory Preset:	REPeat
Range:	Exp Repeat

Remote Command: [:SENSe]:EVM:AVERAge:TCONtrol EXPonential|REPeat
[:SENSe]:EVM:AVERAge:TCONtrol?

Example: EVM:AVER:TCON:EXP
EVM:AVER:TCON?

3.3.8.1.3 Trace Average Type

Choose Trace Average Type among RMS, Max and Min. This selection affects the following average traces: Average Spectrum, Average FSK Spectrum, and Average Error Vector Spectrum. Trace Average Type calculation is different depending on the Average Mode employed, as shown below:

RMS:

Exponential averaging: Exponential averaging is used with a weighting factor of N (the displayed count of averages stops at N). Exponential averaging weights new data more heavily than old data, which allows tracking of slow-changing signals. The weighting factor N is set using the **Avg Number** key. The nth average result A_n is represented by:

$$A_n = \sqrt{\frac{Y_n^2 + (N_w - 1)A_{n-1}^2}{N_w}}, \begin{cases} N_w = n & \text{when } n < N \\ N_w = N & \text{when } n \geq N \end{cases}$$

Repeat averaging: After the number of N averages is reached, all previous result data is cleared. This is equivalent to being in Measure Single and pressing the **Restart** key each time the single measurement finishes. The nth average result A_n is represented by:

$$A_n = \sqrt{\frac{1}{n} \sum_{i=1}^n Y_i^2}$$

Max:

Exponential averaging: Maximum result after measurement restart is held. Previous result data is cleared when measurement restarts.

Repeat averaging: Maximum result obtained after measurement restart or measurement clear. After the number of N averages is reached, previous result data is cleared.

Min:

Exponential averaging: Minimum result after measurement restart is held. Previous result data is cleared when measurement restarts.

Repeat averaging: Minimum result obtained after measurement restart or measurement clear. After the number of N averages is reached, previous result data is cleared.

Front Panel Access

Meas Setup

Remote Command: [:SENSe]:EVM:AVERAge:TRACe[:TYPE] RMS|MAXimum|MINimum
 [:SENSe]:EVM:AVERAge:TRACe[:TYPE] ?

Factory Preset RMS

SCPI Examples :EVM:AVER:TRAC:TYPE RMS
 :EVM:AVER:TRAC:TYPE?

3.3.8.2 Demod

Displays the menu keys that set the demodulation parameters. Refer to the table below for the specific parameter settings for each radio standard and device.

Table 3-2 Radio Standard Settings

Radio Std	Device	Demod Format	Symbol Rate	Meas Filter	Ref Filter	Alpha / BT	Burst Search Length	Meas Interval	Burst Sync
GSM (GMSK)	BTS & MS	MSK Type 1	270.833333ksps	Off	Gaussian	0.3	5.3ms	148	Sync Word Burst
EDGE (8PSK)	BTS & MS	PSK EDGE	270.833333ksps	EDGE	EMF	0.25	5.3ms	142	Sync Word Burst
W-CDMA 3GPP	BTS & MS	QPSK	3.84Msps	Root Raised Cosine	Raised Cosine	0.22	666.7μs	256	None
cdma2000 SR1	BTS	QPSK	1.2288Msps	CDMA BS Ph EQ	IS95 BS	N/A	N/A	200	None
cdma2000 SR1	MS	QPSK	1.2288Msps	Off	IS95 BS	N/A	N/A	200	None
cdmaOne	BTS	QPSK	1.2288Msps	CDMA BS Ph EQ	IS95 BS	N/A	N/A	200	None
cdmaOne	MS	OQPSK	1.2288Msps	Off	IS95 BS	N/A	N/A	200	None
NADC	BTS	$\pi/4$ DQPSK	24.3ksps	Root Raised Cosine	Raised Cosine	0.35	49ms	162	None
NADC	MS	$\pi/4$ DQPSK	24.3ksps	Root Raised Cosine	Raised Cosine	0.35	49ms	157	RF Ampl
PDC	BTS	$\pi/4$ DQPSK	21.0ksps	Root Raised Cosine	Raised Cosine	0.5	48ms	138	None
PDC	MS	$\pi/4$ DQPSK	21.0ksps	Root Raised Cosine	Raised Cosine	0.5	48ms	135	RF Ampl
PHS	BTS	$\pi/4$ DQPSK	192.0ksps	Root Raised Cosine	Raised Cosine	0.5	5.8ms	111	RF Ampl
PHS	MS	$\pi/4$ DQPSK	192.0ksps	Root Raised Cosine	Raised Cosine	0.5	5.8ms	111	RF Ampl
TETRA	BTS	$\pi/4$ DQPSK	18.0ksps	Root Raised Cosine	Raised Cosine	0.35	73ms	246	None
TETRA	MS	$\pi/4$ DQPSK	18.0ksps	Root Raised Cosine	Raised Cosine	0.35	73ms	231	RF Ampl

Table 3-2 Radio Standard Settings

Radio Std	Device	Demod Format	Symbol Rate	Meas Filter	Ref Filter	Alpha / BT	Burst Search Length	Meas Interval	Burst Sync
Bluetooth	N/A	FSK 2	1Msps	Off	Gaussian	0.5	1.7ms	320	None
ZigBee 2450MHz	N/A	OQPSK	1.0Msps	Off	Half Sine	n/a	3.0 ms	1000	RF Ampl
APCO25 phase1	N/A	FSK4	4.8ksps	Rect	RC	0.2	84ms	200	None
VDL Mode3	N/A	D8PSK	10.5ksps	Off	RC	0.6	120ms	315	RF Ampl

3.3.8.2.1 Modulation Format

Accesses the demodulation format menu keys allowing you to specify the demodulation format to use. This parameter is automatically set when a radio standard is selected.

Key Path:	Meas Setup, Demod
Dependencies and Couplings:	The parameter value is set when Radio Std or Radio Device is changed. Changing this value can cause changes of sync word length.
State Saved:	Saved in instrument state.
Factory Preset:	QPSK
Default Terminator:	ENUM
Remote Command:	[:SENSe] :RADio:STANdard:MODulation QPSK BPSK OQPSK PI4DQPSK D8PSK DQPSK EPSK QAM16 QAM32 QAM64 QAM128 QAM256 FSK2 FSK4 FSK8 MSK1 MSK2 EDGE DVBQAM16 DVBQAM32 DVBQAM64 DVBQAM128 DVBQAM256 [:SENSe] :RADio:STANdard:MODulation?
Example:	:RAD:STAN:MOD BPSK :RAD:STAN:MOD?

3.3.8.2.2 Meas Filter

Determines which filter is applied to the incoming signal - that is, to the signal that you are measuring. The **Meas Filter** key accesses the Measurement Filter menu, allowing you to either switch the measurement filter off or to specify one of a selection of different filters:

- Root Nyquist (Root Raised Cosine)
- Nyquist (Raised Cosine)
- Gaussian
- EMF (EDGE)
- CDMA EQ (IS-95 Base)
- Rectangle

Key Path:	Meas Setup, Demod
Dependencies and Couplings:	The parameter value is set when Radio Std or Radio Device is changed.
State Saved:	Saved in instrument state.
Factory Preset:	RNYQuist

Modulation Analysis Measurement Keys

Remote Command: `[:SENSe] :RADio:STANdard:FILTer:MEASurement NONE | RNYquist
| NYquist | GAUSSian | CDMA | EMF | RECTangle
[:SENSe] :RADio:STANdard:FILTer:MEASurement?`

Example: `:RAD:STAN:FILT:MEAS RNYQ
:RAD:STAN:FILT:MEAS?`

3.3.8.2.3 Ref Filter

Determines which filter is applied to the reference signal - that is, the ideal signal with which you compare your measurement signal. The **Ref Filter** key accesses the Reference Filter menu, allowing you to specify one of a selection of different filters:

- Root Nyquist
- Nyquist
- Gaussian
- EDGE
- CDMA
- Rectangle
- Half Sine

Key Path:	Meas Setup, Demod
Dependencies and Couplings:	Parameter value is set when Radio Std or Radio Device is changed.
State Saved:	Saved in instrument state.
Factory Preset:	NYQuist
Remote Command:	<code>[:SENSe] :RADio:STANdard:FILTer:REFerence RNYquist NYquist GAUSSian CDMA EDGE RECTangle HSINE [:SENSe] :RADio:STANdard:FILTer:REFerence?</code>
Example:	<code>:RAD:STAN:FILT:REF RNYQ :RAD:STAN:FILT:REF?</code>

3.3.8.2.4 Alpha/BT

Use the numeric keypad to determine the filter shape of the Nyquist and Gaussian filters. Alpha, sometimes called ‘excess bandwidth factor’, applies only to Nyquist and Root Nyquist filters. BT (‘Bandwidth Time’ product) applies only to Gaussian filters. This key is unavailable for all filters that are neither Root Nyquist nor Gaussian.

Key Path:	Meas Setup, Demod
Dependencies and Couplings:	The parameter value is set when Radio Std or Radio Device is changed. Alpha applies only to Nyquist and Root Nyquist filters. BT only applies to Gaussian filters.
State Saved:	Saved in instrument state.
Factory Preset:	0.22
Range:	0.01–1.0
Remote Command:	<code>[:SENSe] :RADio:STANdard:ALPHa</code> <code>[:SENSe] :RADio:STANdard:ALPHa?</code>
Example:	<code>:RAD:STAN:ALPH 0.65</code> <code>:RAD:STAN:ALPH?</code>

3.3.8.2.5 Symbol Rate

Sets the symbol rate for your modulation format or radio design. For preset radio standards the symbol rate defaults to the radio standard symbol rate but it can be modified to a symbol to meet your design and testing needs.

Key Path:	Meas Setup, Demod
Dependencies and Couplings:	The parameter value is set when Radio Std or Radio Device is changed.
State Saved:	Saved in instrument state.
Factory Preset:	3.84MHz
Default Terminator:	Hz
Range:	1k – 10MHz With Option 122, 80 MHz Bandwidth Digitizer installed, Wide = 10 kHz - 80 MHz With Option 140, 40 MHz Bandwidth Digitizer installed, Wide = 10 kHz - 40 MHz
Remote Command:	<code>[:SENSe] :RADio:STANdard:SRATe <frequency></code> <code>[:SENSe] :RADio:STANdard:SRATe?</code>
Example:	<code>:RAD:STAN:SRAT 6785000</code> <code>:RAD:STAN:SRAT?</code>

3.3.8.2.6 Meas Interval

Sets the number of symbols that are used in calculating the measurement. This key is linked to the **I/Q Points** key and the **Points/Symbol** key in the Display menu.

Key Path:	Meas Setup, Demod
Dependencies and Couplings:	Changing the Meas Interval sets IQ Points and IQ Points Offset Meas Interval and 0 Symbols respectively.
State Saved:	Saved in instrument state.
Factory Preset:	256 Symbol
Default Terminator:	Symbol
Range:	10 to 20000 Symbol (Depends on setting of points/symbol)
Remote Command:	<code>[:SENSe] :EVM:SWEep:POINts <integer></code> <code>[:SENSe] :EVM:SWEep:POINts?</code>
Example:	<code>EVM:SWE:POIN 250</code> <code>EVM:SWE:POIN?</code>

3.3.8.3 Trig Source

Displays menu keys that enable you to select the trigger mode of a measurement. When in a trigger mode other than Free Run, the analyzer will begin the measurement only with the proper trigger condition. The available trigger modes are as follows:

- **Free Run:** The next measurement is taken immediately, capturing the signal asynchronously (also called 'immediate').
- **Video:** An internal IF envelope trigger that occurs at the absolute threshold level of the IF signal level.
- **RF Burst:** Sets the measurement trigger to the leading edge of an RF Burst signal. No measurement will be made unless a bursted signal is being received.
- **Ext Front:** Sets the trigger directly to an external signal connected to the front-panel EXT TRIGGER INPUT connector. No measurement will be made unless a signal is connected to the EXT TRIGGER INPUT connector on the front-panel.
- **Ext Rear:** Sets the trigger directly to an external signal connected to the rear-panel TRIGGER IN connector. No measurement will be made unless a signal is connected to the TRIGGER IN connector on the rear panel.
- **Frame:** Uses the internal frame clock to generate a trigger signal. The clock parameters are controlled under the **Mode Setup** key or the measurement firmware, but not both. Refer to the specific measurement section for details.

Key Path:	Meas Setup
State Saved:	Saved in instrument state.
Factory Preset:	IMMEDIATE
Range:	Free Run (Immediate) Video (IF Envp) RF Burst (Wideband) Ext Front Ext Rear Frame
Remote Command:	[:SENSe] :EVM:TRIGger:SOURce IMMEDIATE IF RFBurst EXTERNAL [1] EXTERNAL2 FRAME [:SENSe] :EVM:TRIGger:SOURce?
Example:	:EVM:TRIG:SOUR RFB :EVM:TRIG:SOUR?

3.3.8.4 Burst/Sync Search

Displays menu keys that enable you to select the parameters to define your burst or sync word search.

3.3.8.4.1 Sync

Displays a key menu which enables you to select the type of burst synchronization. The selection is as follows:

- **RF Amplitude:** Synchronization, and hence demodulation, starts at the beginning of the first valid burst detected. This is only applicable to bursted radio signals such as NADC, PDC and TETRA.
- **Sync Word Continuous:** The synchronization pattern (sync word) is used to determine when to start demodulation. Depending on the search length, the analyzer will search for a synchronization pattern within the search length based on a continuous search (there is no
- **Burst Search Threshold** level to determine if a burst is demodulated). The analyzer demodulates the entire pulse to locate the sync word. For multiple pulses located within the search length, the analyzer demodulates only the first pulse.
- **Sync Word Burst:** The synchronization pattern (sync word) is used to determine when to start demodulation. Depending on the search length, the analyzer will search for a pulse within the search length. The burst must meet the Burst Search Threshold level to be demodulated. The analyzer demodulates the entire pulse to locate the sync word. For multiple pulses located within the search length, the analyzer demodulates only the first pulse.

Key Path:	Meas Setup, Burst/Sync Search
State Saved:	Saved in instrument state.
Default Terminator:	ENUM
Range:	None RF Ampl Sync Word Cont Sync Word Burst
Remote Command:	[:SENSe] :EVM:SYNC:SOURce NONE RFAMPLITUDE SWORD SWBURST [:SENSe] :EVM:SYNC:SOURce?

Example: : EVM:SYNC:SOUR SWOR
 : EVM:SYNC:SOUR?

3.3.8.4.2 Burst Search Threshold

Enables you to set the threshold level of the burst search. The threshold level is relative to the peak power of the signal.

Key Path: **Meas Setup, Burst/Sync Search**

State Saved: Saved in instrument state.

Factory Preset: - 20 dB

Default Terminator: dB

Range: - 100 to 0.0 dB

Remote Command: [:SENSe] :EVM:SYNC:STHreshold <rel_amp1>
 [:SENSe] :EVM:SYNC:STHreshold?

Example: : EVM:SYNC:STHR -12.6
 : EVM:SYNC:STHR?

3.3.8.4.3 Search Length

Specifies the length of time over which the search is performed. As the symbol rate increases, more and more samples are needed to correctly demodulate the burst. Increasing the **Search Length** value increases the size of the sample record up to its maximum value. Beyond this point, the **Search Length** value will be clipped

Key Path: **Meas Setup, Burst/Sync Search**

Dependencies and Couplings: Max value:
 IF Band Width ≤ 100kHz --- 0.5sec
 Band Width ≤ 1 MHz --- 0.1sec
 1MHz < IF Band Width ≤ 10MHz --- 0.05sec
 10MHz < IF Band Width ≤ 20MHz --- 0.025sec
 20MHz < IF Band Width ≤ 40MHz --- 0.013sec
 40MHz < IF Band Width --- 0.007sec

 Min value:
 IF Band Width ≤ 10MHz --- 0.001sec
 IF Band Width ≤ 10MHz --- 10usec
 10MHz < IF Band Width --- 0.1usec

State Saved: Saved in instrument state.

Factory Preset: 0.01 seconds

Default Terminator: seconds

Range: 1m to 0.1 seconds

Remote Command: [:SENSe]:EVM:SYNC:SLENgth <seconds>
 [:SENSe]:EVM:SYNC:SLENgth?

Example: :EVM:SYNC:SLEN 0.02
 :EVM:SYNC:SLEN?

3.3.8.4.4 Sync Pattern

Configures a sync pattern up to 32 symbols in hexadecimal format. The sync pattern is used to resolve carrier phase ambiguity on non-differential modulation formats. The sync pattern is used in the sync search to isolate a segment of your signal for display and analysis. The analyzer searches through demodulated data to find your sync pattern.

Key Path: **Meas Setup, Burst/Sync Search**

State Saved: Saved in instrument state.

Factory Preset: 0000

Range: Hexadecimal

Remote Command: [:SENSe]:EVM:SYNC:SWORd:PATTern <hexadecimal>
 [:SENSe]:EVM:SYNC:SWORd:PATTern?

Example: :EVM:SYNC:SWOR:PATT 1C
 :EVM:SYNC:SWOR:PATT?

3.3.8.4.5 Sync Word Length

Sets the length (in symbols) of the sync word.

Key Path: **Meas Setup, Burst/Sync Search**

Dependencies and Couplings: As sync pattern length is limited to 128 bits, the value is clipped to the max value that satisfy $\text{codeWordLength} \text{ (defined by demod format) } * \text{SyncWordLength} \leq 128$.

State Saved: Saved in instrument state.

Factory Preset: 10 Symbols

Default Terminator: Symbols

Remote Command: [:SENSe]:EVM:SYNC:SWORd:LENgth <integer>
 [:SENSe]:EVM:SYNC:SWORd:LENgth?

Example: :EVM:SYNC:SWOR:LENG 30
 :EVM:SYNC:SWOR:LENG?

3.3.8.4.6 Sync Offset

Specifies an offset, in symbols, to determine the location of the result length with a Search Length. You can specify a positive or negative offset.

Key Path: **Meas Setup, Burst/Sync Search**

Modulation Analysis Measurement Keys

State Saved: Saved in instrument state.

Factory Preset: 0 Symbols

Default Terminator: Symbols

Range: – 1000 to 1000 Symbols

Remote Command: [:SENSe]:EVM:SYNC:SWORd:OFFSet <integer>
[:SENSe]:EVM:SYNC:SWORd:OFFSet?

Example: :EVM:SYNC:SWOR:OFFS 150
:EVM:SYNC:SWOR:OFFS?

3.3.8.5 Meas Setup...

Accesses the measurement setup form. Use the front-panel arrow keys located beneath the display, to highlight the parameter you wish to specify. Use the front-panel alpha-numeric keypad or the up down arrow keys (located below the front-panel knob) to enter your desired setting. The units for each parameter are available in the key menu after you select the numeric values. See “[Modifying Measurement Setup Parameters](#)” on page 52 of the Making Measurements Chapter for an example using this form.

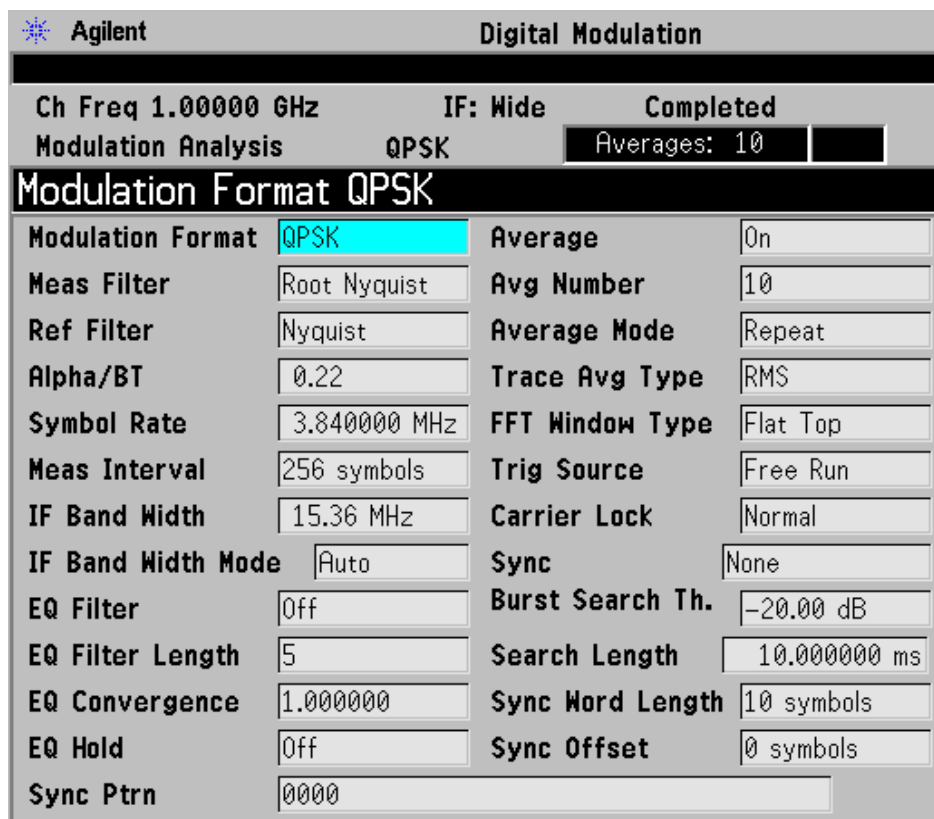

3.3.8.6 Equalization

Displays menu keys that enable you to select the parameters to define equalization. Equalization allows measurement of some impaired channels and can be used to isolate linear from non-linear error mechanisms. Equalization does not require symbol lock or prior knowledge of the signal (such as a training sequence) and is compatible with recorded data.

3.3.8.6.1 EQ Filter

Turns the equalization filter on and off. The equalization filter removes linear errors from modulated signals by dynamically creating and applying a compensating filter.

Key Path:	Meas Setup, Equalization
State Saved:	Saved in instrument state.
Factory Preset:	OFF
Range:	Off On
Remote Command:	<code>[:SENSe] :EVM:EQUalization [:STATe] OFF ON 0 1</code> <code>[:SENSe] :EVM:EQUalization [:STATe] ?</code>
Example:	<code>:EVM:EQU OFF</code> <code>:EVM:EQU?</code>

3.3.8.6.2 EQ Filter Length

The equalization filter length sets the filter length from 3 to 9 symbols. Typically the best filter length is the smallest that meets your measurement requirements. For example, when selecting a filter length, if your measurement is at the transmitter you will need a short filter length. If you are measuring in a multi-path environment, your filter length may need to be longer. The filter length also determines the placement of the impulse response in the equalization filter.

Key Path:	Meas Setup, Equalization
State Saved:	Saved in instrument state.
Factory Preset:	5 Symbols
Default Terminator:	Symbols
Range:	3 to 99 Symbols
Remote Command:	<code>[:SENSe] :EVM:EQUalization:FLENgth <integer></code> <code>[:SENSe] :EVM:EQUalization:FLENgth?</code>
Example:	<code>:EVM:EQU:FLEN 7</code> <code>:EVM:EQU:FLEN?</code>

3.3.8.6.3 EQ Convergence

Equalizer convergence determines how quickly the equalization-filter coefficients converge to the estimated values. When choosing convergence values remember that large values converge faster than smaller values. In some cases if you choose a large convergence value, the adaptation algorithm has risk of becoming unstable, limiting the minimum value of EVM or SNR. You can adjust the convergence value while the adaptation algorithm is running. For example, when the EQ filter is first turned on, the chosen convergence value may be large to obtain a faster convergence, and then the convergence value can be decreased to obtain better results.

Key Path:	Meas Setup, Equalization
State Saved:	Saved in instrument state.
Factory Preset:	1.0
Range:	1.0E-3 to 100
Remote Command:	<code>[[:SENSe]:EVM:EQUalization:CONVergence <real></code> <code>[[:SENSe]:EVM:EQUalization:CONVergence?</code>
Example:	<code>:EVM:EQU:CONV 75.342</code> <code>:EVM:EQU:CONV?</code>

3.3.8.6.4 EQ Hold

If **EQ Hold** is on, the analyzer does not update the filter coefficients. Instead, the analyzer uses the last updated coefficients before EQ Hold was enabled. If EQ Hold is on, it can be turned off (during the measurement) to continue updating the filter coefficients. Unless the equalization filter is reset, the analyzer uses the last updated filter coefficients.

Key Path:	Meas Setup, Equalization
Soft Key Label:	EQ Hold
State Saved:	Saved in instrument state.
Factory Preset:	OFF
Range:	Off On
Remote Command:	<code>[[:SENSe]:EVM:EQUalization:HOLD[:STATe] OFF ON 0 1</code> <code>[[:SENSe]:EVM:EQUalization:HOLD[:STATe]?</code>
Example:	<code>:EVM:EQU:HOLD ON</code> <code>:EVM:EQU:HOLD?</code>

3.3.8.6.5 Reset EQ Filter

The equalization filter is a unit impulse response when the EQ Filter is first turned on. If EQ Hold is off, the analyzer then reshapes the equalization filter after each subsequent measurement. Press the **Reset EQ Filter** key to reset the equalization filter back to a unit impulse response.

Key Path: **Meas Setup, Equalization**
 Remote Command: [:SENSe]:EVM:EQUalization:RESet
 Example: :EVM:EQU:RES

3.3.8.7 Carrier Lock

Sets Carrier Lock to Normal or Wide. With Carrier Lock set to Wide, the analyzer has a wider frequency lock range but the trade-off for having a wide lock range is a decrease in robustness when measuring distorted signals, or with faster measurements. This function is only available when the modulation format is PSK or QAM, with the exception of 32 QAM and 128 QAM.

Key Path: **Meas Setup, More**
 State Saved: Saved in instrument state.
 Factory Preset: NORMAl
 Default Terminator: ENUM
 Range: Normal|Wide
 Remote Command: [:SENSe]:EVM:CLOCK NORMAl|WIDE
 [:SENSe]:EVM:CLOCK?
 Example: :EVM:CLOC NORM
 :EVM:CLOC?

3.3.8.8 FFT Window Type

Sets the FFT Window Type. All spectrum results in Modulation Analysis are calculated using this FFT window. Spectrum traces available are:

- RF Spectrum
- Error Vector Spectrum
- FSK Error Spectrum

Front Panel Access **Meas Setup, More**
 SCPI Name FFT Window Type
 Remote Command: [:SENSe]:EVM:FFT:WINDow[:TYPE]
 UNIFORM|FTOP|HANNing|GAUSSian
 [:SENSe]:EVM:FFT:WINDow[:TYPE]?
 Preset/Default FTOP

Modulation Analysis Measurement Keys

State Saved	Yes
SCPI Examples	:EVM:FFT:WIND FTOP :EVM:FFT:WIND?

3.3.8.9 IF Band Width

Sets the width of the intermediate frequency (IF) filter. The preset state is 10 MHz and is set to Auto. When set to Auto, the width is set with respect to the demodulation format and symbol rate.

Key Path:	Meas Setup, More, Advanced
Dependencies and Couplings:	When the mode is AUTO, the width value is set with respect to the Demod Format and Symbol Rate.
State Saved:	Saved in instrument state.
Factory Preset:	10MHz, ON
Default Terminator:	Hz
Range:	1k to 10MHz, OFF ON 0 1 With Option 122, 80 MHz Bandwidth Digitizer installed, Wide = 10 kHz - 80 MHz With Option 140, 40 MHz Bandwidth Digitizer installed, Wide = 10 kHz - 40 MHz
Remote Command:	[[:SENSe]:EVM:IFBwidth <frequency> [:SENSe]:EVM:IFBwidth? [:SENSe]:EVM:IFBwidth:AUTO OFF ON 0 1 [:SENSe]:EVM:IFBwidth:AUTO?
Remote Command Notes:	OFF ON 0 1
Example:	:EVM:IFBW 6576000 :EVM:IFBW? :EVM:IFBW:AUTO 1 :EVM:IFBW:AUTO?

3.3.8.10 Advanced

Accesses the Advanced key menu to change the following parameters:

3.3.8.10.1 Limits

Accesses the Limits key menu to change the following parameters:

3.3.8.10.1.1 RMS EVM

Sets an RMS EVM limit to warn you if the measured average RMS EVM value exceeds a limit. When the RMS EVM limit is on and the average RMS EVM result exceeds the limit, a red FAIL indicator appears in the PASS/FAIL window. When the RMS EVM limit is on and the average RMS EVM result is less than the

limit, a green PASS indicator appears in the PASS/FAIL window.

Key Path: Meas Setup, Advanced, Limits

State Saved: Saved in instrument state.

Factory Preset: 50 %, OFF

Default Terminator: %

Range: 0 to 100 %, On | Off

Remote Command: :CALCulate:EVM:LIMit:RMS <real>
 :CALCulate:EVM:LIMit:RMS?
 :CALCulate:EVM:LIMit:RMS:STATe ON|OFF|1|0
 :CALCulate:EVM:LIMit:RMS:STATe?

Example: :CALC:EVM:LIM:RMS 43
 :CALC:EVM:LIM:RMS?
 :CALC:EVM:LIM:RMS:STAT ON
 :CALC:EVM:LIM:RMS:STAT?

3.3.8.10.1.2 Freq Error

Set a frequency error limit to warn you if the measured average frequency error value exceeds a limit. When the Freq Error limit is on and the average frequency error result exceeds the limit, a red FAIL indicator appears in the PASS/FAIL window. When the Freq Error limit is on and the average frequency error result is less than the limit, a green PASS indicator appears in the PASS/FAIL window.

Key Path: Meas Setup, Advanced, Limits

State Saved: Saved in instrument state.

Factory Preset: 10k, OFF

Range: 0 to 500k, On | Off

Remote Command: :CALCulate:EVM:LIMit:FERRor <frequency>
 :CALCulate:EVM:LIMit:FERRor?
 :CALCulate:EVM:LIMit:FERRor:STATe ON|OFF|1|0
 :CALCulate:EVM:LIMit:FERRor:STATe?

Example: :CALC:EVM:LIM:FERR 25300
 :CALC:EVM:LIM:FERR?
 :CALC:EVM:LIM:FERRor:STAT ON
 :CALC:EVM:LIM:FERRor:STAT?

3.3.8.10.2 Spectrum

Set Spectrum to Invert to demodulate the signal with the spectrum inverted (mirrored, flipped) about the center frequency. By default, the signal is demodulated without inverting (Spectrum set to Normal) the frequency spectrum.

Key Path:	Meas Setup, Advanced
State Saved:	Saved in instrument state.
Factory Preset:	NORMal
Default Terminator:	ENUM
Range:	Normal Invert
Remote Command:	<code>[:SENSe] :EVM:SPECTrum NORMal INVert</code> <code>[:SENSe] :EVM:SPECTrum?</code>
Example:	<code>:EVM:SPEC INV</code> <code>:EVM:SPEC?</code>

3.3.8.10.3 Clock Adjust

The analyzer does not require symbol-clock timing signals to determine the location of symbols (decision points). Instead, the digital demodulator uses an algorithm to determine symbol locations. Some digital communication systems contain non-linearity that can influence the digital demodulator's estimation of the symbol clock position. You can use **Clock Adjust** to compensate for the symbol clock position estimation to obtain lower EVM results.

When **Clock Adjust** is set you can see the effects on constellation diagram or eye diagram displays. Increasing (or decreasing) clock adjust shifts the detection-decision points and slides the eye diagram right or left (remember that in the eye diagram, the symbol locations remain in a fixed location on the display; therefore, changing the location of symbols has the effect of horizontally shifting the eye diagram).

Key Path:	Meas Setup, Advanced
State Saved:	Saved in instrument state.
Factory Preset:	0 Symbols
Default Terminator:	Symbols
Range:	- 0.5 to 0.5 Symbols
Remote Command:	<code>[:SENSe] :EVM:CADJust <real></code> <code>[:SENSe] :EVM:CADJust?</code>
Example:	<code>:EVM:CADJ -0.23</code> <code>:EVM:CADJ?</code>

3.3.8.10.4 EVM Ref Calc Mode (QAM only)

EVM Reference Calculation is available when demodulating one of the QAM formats. Use the following equation to determine EVM:

$$\text{EVM (\%)} = ((\text{Error Vector Magnitude}) / (\text{Reference Vector Magnitude})) * 100.$$

When the EVM Reference Calculation is set to RMS, the RMS magnitude of all QAM decision points are used as the reference. When it is set to Max, the magnitude of the decision points with largest distance from the origin are used as the reference.

Key Path:	Meas Setup, More, Advanced
State Saved:	Saved in instrument state.
Factory Preset:	RMS
Range:	RMS Max
Remote Command:	<code>[:SENSe] :EVM:CMODE RMS MAXimum</code> <code>[:SENSe] :EVM:CMODE?</code>
Example:	<code>:EVM:CMOD MAX</code> <code>:EVM:CMOD?</code>

NOTE For backward compatibility, SCPI enum MEAN is accepted for RMS setting.

3.3.8.10.5 ADC Range

Access the following selection menu to define one of the ADC ranging functions:

Access the following selection menu

to define one of the ADC ranging functions:

- **Auto:** Select this to set the ADC range automatically.
- **Auto Peak:** Select this to set the ADC range automatically to the peak signal level. Auto Peak is a compromise that works well for both CW and burst signals.
- **Auto Peak Lock:** Select this to hold the ADC range
- **Manual:** Allows you to select one of the following ADC range levels:

0 dB, +6 dB, +12 dB, +18 dB.

Select None to lock the range at the present value without specifying a value. Manual range setting provides the best measurement results for CW signals. If the input signal level is very close to the ADC range level selected, the noise floor of the measurement can vary by as much 6db, as the range changes with input power variations.

Key Path:	Meas Setup, Advanced
State Saved:	Saved in instrument state.

Modulation Analysis Measurement Keys

Factory Preset: Auto

Remote Command: [:SENSe] :EVM:ADC:RANGe
 AUTO | NONE | Autopeaklock | ENVL | 0dB | 6dB | 12dB | 18dB

 [:SENSe] :EVM:ADC:RANGe?

Example: :EVM:ADC:RANG NONE

3.3.8.10.6 IQ Scaling

Selects IQ Scaling mode. The following modes are available:

- Max Measured Decision Point
- Max Reference Decision Point
- Measured RMS

The traces affected by this selection are:

- Measured IQ Vector
- Reference IQ Vector

Front Panel Access **Meas Setup, More, Advanced, More**

SCPI Name IQ Scaling

Remote Command: [:SENSe] :EVM:NORMalize:IQ MMDPoint | MRMS | MRDPoint

 [:SENSe] :EVM:NORMalize:IQ?

Preset/Default MRDPoint

State Saved Yes

SCPI Examples :EVM:NORM:IQ MDM

 :EVM:NORM:IQ?

3.3.8.10.7 FSK Normalize

Selects FSK Normalize mode On or OFF. Traces affected by this selection are: Measured IQ Vector, Reference IQ Vector, FSK Meas Time, FSK Ref Time, FSK Error vs Time, and FSK Error Spectrum.

Front Panel Access **Meas Setup, More, Advanced, More**

Remote Command: [:SENSe] :EVM:NORMalize:FSK ON | OFF | 0 | 1

 [:SENSe] :EVM:NORMalize:FSK?

Preset/Default ON

State Saved Yes

SCPI Examples :EVM:NORM:FSK ON
 :EVM:NORM:FSK?

3.3.8.10.8 IF Path

Press the **IF Path** key to toggle the path between Wideband and Narrowband IF paths.

Key Path: **Meas Setup, More**
 State Saved: Saved in instrument state.
 Factory Preset: WIDE
 Default Terminator: ENUM
 Range: Narrow | Wide
Remote Command: [:SENSe]:EVM:IFPath NARROW|WIDE
 [:SENSe]:EVM:IFPath?
 Example: :EVM:IFPath NARROW
 :EVM:IFPath?

3.3.8.10.9 Wideband IF Gain

Sets the Wideband IFGain.

Key Path: **Meas Setup, More, Wideband Setup**
 State Saved: Saved in instrument state.
 Factory Preset: 0 dB
 Default Terminator: dB
 Range: – 12 to 12 dB
Remote Command: [:SENSe]:EVM:WBIF:IFGain <integer>
 [:SENSe]:EVM:WBIF:IFGain?
 Example: :EVM:WBIF:IFG 0
 :EVM:WBIF:IFG?

3.3.8.10.10 Wideband Setup

Press the **Wideband Setup** key to access a menu allowing you to set up the Wideband Advanced parameters.

3.3.8.10.11 Wideband Advanced

Press the **Wideband Advanced** key to access a menu allowing you to set up advanced features for the Wideband IF path.

3.3.8.10.11.1 ADC Corr

This performs the ADC calibration to reduce the spectral image and applies the correction.

Key Path:	Meas Setup, More, Wideband Setup, Wideband Advanced
Dependencies and Couplings:	This parameter is coupled with ADC Correction of other measurements.
State Saved:	Saved in instrument state.
Factory Preset:	ON
Range:	Off On
Remote Command:	<code>[:SENSe] :EVM:WBIF:ADCCorrect OFF ON 0 1</code> <code>[:SENSe] :EVM:WBIF:ADCCorrect?</code>
Example:	<code>:EVM:WBIF:ADCCorrect ON</code> <code>:EVM:WBIF:ADCCorrect?</code>

3.3.8.10.11.2 IF Flat Corr

Turns IF flatness corrections on and off in all wideband IF measurements.

Key Path:	Meas Setup, More, Wideband Setup, Wideband Advanced
Dependencies and Couplings:	This parameter is coupled with WBIF Flatness of other measurements.
State Saved:	Saved in instrument state.
Factory Preset:	ON
Range:	Off On
Remote Command:	<code>[:SENSe] :EVM:WBIF:FLATness OFF ON 0 1</code> <code>[:SENSe] :EVM:WBIF:FLATness?</code>
Example:	<code>:EVM:WBIF:FLATness ON</code> <code>:EVM:WBIF:FLATness?</code>

3.3.8.10.11.3 WB ADC Dither

This turns the wideband dither signal on or off. This control is independent of the narrowband ADC dither.

Key Path:	Meas Setup, More, Wideband Setup, Wideband Advanced
State Saved:	Saved in instrument state.
Factory Preset:	OFF
Range:	Off On
Remote Command:	<code>[:SENSe] :EVM:WBIF:ADC:DITHer OFF ON 0 1</code> <code>[:SENSe] :EVM:WBIF:ADC:DITHer?</code>

Example: : EVM:WBIF:ADC:DITHer ON
 : EVM:WBIF:ADC:DITHer?

3.3.8.10.11.4 Trig Interp

Turns trigger interpolation on and off. At lower sample rates, interpolating the trigger results in a loss of the LO phase lock. To allow for continuous lock, a method of turning off the trigger interpolation has been added. When interpolation is turned off, the trigger offset is returned by means of the EVM:WBIF:TRIG:EOFFset command. Applies only for external trigger.

Key Path: **Meas Setup, More, Wideband Setup, Wideband Advanced**

State Saved: Saved in instrument state.

Factory Preset: ON

Range: Off|On

Remote Command: [:SENSe]:EVM:WBIF:TRIGger:INTerpolate OFF|ON|0|1
 [:SENSe]:EVM:WBIF:TRIGger:INTerpolate?

Example: : EVM:WBIF:TRIGger:INTerpolate ON
 : EVM:WBIF:TRIGger:INTerpolate?

3.3.8.10.12 Wide Carrier Estimator

Press the **IF Path** key to toggle between Wide and Narrow IF paths.

Front Panel Access **Meas Setup, More, Advanced, More, More**

Remote Command: [:SENSe]:EVM:CLOCK:WIDE:AUTO ON|OFF|0|1
 [:SENSe]:EVM:CLOCK:WIDE:AUTO?

Factory Preset ON

State Saved Yes

Coupling None

Restriction and Notes This soft key is active only when Demod Format is either 16QAM, 64QAM or 256QAM and Carrier Lock is Wide.

SCPI Examples : EVM:CLOCK:WIDE:AUTO OFF
 : EVM:CLOCK:WIDE:AUTO?

History Available from A.08.XX

3.3.8.10.13 Estimator Range

Set range of wide carrier estimator. When Carrier Lock is Wide, wide carrier estimator looks for carrier from this range.

Front Panel Access	Meas Setup, More, Advanced, More, More
Remote Command:	<code>[:SENSe] :EVM:CLOCK:WIDE:MRANge <freq></code> <code>[:SENSe] :EVM:CLOCK:WIDE:MRANge?</code>
Unit/Termination	Hz
Preset/Default	10.0kHz
State Saved	Yes
Range	1 – 40M
Min	1
Max	40M
SCPI Resolution	1
Resolution Max	11
Restriction and Notes	This key is active when the Wide Carrier Estimator key is active and set to Manual.
SCPI Examples	<code>:EVM:CLOCK:WIDE:MRANge 10000</code> <code>:EVM:CLOCK:WIDE: MRANge?</code>
History	Available from A.08.XX

3.3.8.10.14 Amp Droop Compensation

Toggles Amplitude Droop Compensation on or off. When this is ON, the amplitude droop is compensated for and the magnitude error becomes smaller. This setting is not effective for MSK and FSK formats.

Front Panel Access	Meas Setup, More, Advanced, More, More
SCPI Name	Amp Droop Compensation
Remote Command:	<code>[:SENSe] :EVM:ADRoop:COMPensation ON OFF 0 1</code> <code>[:SENSe] :EVM:ADRoop:COMPensation?</code>
Unit/Termination	ENUM
Preset/Default	ON
State Saved	Yes
Range	OFF ON 0 1
Coupling	None

Restriction and Notes	This soft key is not active only when Demod Format is either one of FSK and MSK families.
SCPI Examples	:EVM:ADR:COMP ON :EVM:ADR:COMP?
History	Available from A.08.XX

3.3.8.10.15 Immediate Update

Toggles Immediate Update on or off. When active (On), the analyzer starts a new calculation using the latest previously captured signal immediately after a setup parameter is changed.

When the IFBW of new setting is either smaller than 0.8* actual IFBW or larger than 1.1* actual IFBW, no recalculation is performed, and the results are calculated with the previous, settings.

Front Panel Access	Meas Setup, More, Advanced, More, More
SCPI Name	Immediate Update
Remote Command:	[:SENSe] :EVM:IUPDate ON OFF 0 1 [:SENSe] :EVM:IUPDate?
Preset/Default	ON
State Saved	Yes
SCPI Examples	:EVM:IUPD ON :EVM:IUPD?
History	Available from A.08.XX

3.3.9 SPAN X Scale

This function controls how data on the horizontal (X) axis is displayed and controls instrument settings that affect the horizontal axis.

The Scale Coupling for the X scale never changes the Ref Position setting and sets the Ref Value and the Scale/Div to make the entire trace data fit the width or height of the window.

Table 3-3 X Scale Units and Default Settings

State Saved Window Name	X Scale Unit	Scale / Div	X-Scale Defaults		
			Ref Position	Ref Value	Scale Coupling
EVM	symbol	1.0	Left	0.0	On
Mag Error	symbol	1.0	Left	0.0	On
Phase Error	symbol	1.0	Left	0.0	On
Numeric Results	N/A	N/A	N/A	N/A	N/A
IQ Measured Polar Graph, IQ Reference Vector	no unit	N/A	N/A	N/A	N/A
Eye I	symbol	N/A	N/A	N/A	N/A
Eye Q	symbol	N/A	N/A	N/A	N/A
IQ Measured Polar Vector	no unit	N/A	N/A	N/A	N/A
FSK Error	symbol	1.0	Left	0.0	On
FSK Error Spectrum	Hz	1.0	Left	0.0	On
FSK Measured Time	symbol	1.0	Left	0.0	On
RF Spectrum	Hz	5.0	Ctr	N/A	N/A
Error Vector Spectrum	Hz	5.0	Ctr	N/A	N/A
Equalizer Channel Response	Hz	1.0	Left	0.0	On
Equalizer Impulse Response	symbol	1.0	Ctr	0.0	On
Channel Response (Phase)	Hz	1.0	Left	0.0	On

3.3.9.1 Scale / Div

Set the horizontal scale by changing the value per division. X Scale/Div can be set in the I/Q Error and FSK Error displays (located under the Trace/View menu). When the Scale Coupling default is On, this value is automatically determined by the measurement results. When you set a value manually, Scale Coupling automatically changes to Off.

Key Path: **SPAN X Scale**

Dependencies and Couplings: Change of this forces X Scale Coupling off.

Restriction: Default value is set by the Scale Coupling function by referencing the trace.

State Saved: Saved in instrument state.

Default Terminator: symbol

Remote Command: :DISPlay:EVM[1] | 2 | 3 | 4 | 5 | 6 | 7 | 8 :WINDow[1] | 2 | 3 | 4 :
 TRACe:X[:SCALe]:PDIVision <real>
 :DISPlay:EVM[1] | 2 | 3 | 4 | 5 | 6 | 7 | 8 :WINDow[1] | 2 | 3 | 4 :TRACe:X[:SCALe]:
 PDIVision?

Example: :DISP:EVM1:WIND3:TRAC:X:PDIV 154782
 :DISP:EVM1:WIND3:TRAC:X:PDIV?

3.3.9.2 Ref Value

Set the reference value of the horizontal axis. However, since the Scale Coupling default is On, this value is automatically determined by the measurement results. When you set a value manually, Scale Coupling automatically changes to Off.

Key Path: **SPAN X Scale**

Dependencies and Couplings: Change of this forces X Scale Coupling off.

State Saved: Saved in instrument state.

Default Terminator: Symbol

Remote Command: :DISPlay:EVM[1] | 2 | 3 | 4 | 5 | 6 | 7 | 8 :WINDow[1] | 2 | 3 | 4 :TRACe:X[:SCALe]:RL
 EVe1 <real>
 :DISPlay:EVM[1] | 2 | 3 | 4 | 5 | 6 | 7 | 8 :WINDow[1] | 2 | 3 | 4 :TRACe:X[:SCALe]:RL
 EVe1?

Example: :DISP:EVM3:WIND2:TRAC:X:RLEV 52341
 :DISP:EVM3:WIND2:TRAC:X:RLEV?

3.3.9.3 Ref Position

Set the reference position to Left, Ctr (center) or Right. The default setting is Left.

Key Path:	SPAN X Scale
Dependencies and Couplings:	When X Scale Coupling is on, changing this function forces the X Scale Reference to change, ensuring the trace fits in the window.
State Saved:	Saved in instrument state.
Factory Preset:	LEFT
Default Terminator:	ENUM
Range:	Left Ctr Right
Remote Command:	:DISPlay:EVM[1] 2 3 4 5 6 7 8 :WINDow [1] 2 3 4 : TRACe:X[:SCALe]:RPOSition LEFT CENTer RIGHT :DISPlay:EVM[1] 2 3 4 5 6 7 8 :WINDow [1] 2 3 4 :TRACe:X[: SCALe]:RPOSition?
Example:	:DISP:EVM3:WIND2:TRAC:X:RPOS RIGH :DISP:EVM3:WIND2:TRAC:X:RPOS?

3.3.9.4 Scale Coupling

Toggle the scale coupling function between On and Off. The default setting is On. Upon pressing the Restart front-panel key or Restart softkey under the Meas Control menu, this function automatically determines the scale per division and reference values based on the measurement results. When you set a value to either Scale/Div or Ref Value manually, Scale Coupling automatically changes to Off.

Key Path:	SPAN X Scale
Dependencies and Couplings:	Turning this function On sets X Scale / Div and X Scale Reference to the appropriate values.
State Saved:	Saved in instrument state.
Factory Preset:	ON
Range:	Off On
Remote Command:	:DISPlay:EVM[1] 2 3 4 5 6 7 8 :WINDow [1] 2 3 4 :TRACe: X[:SCALe]:COUPle OFF ON 0 1 :DISPlay:EVM[1] 2 3 4 5 6 7 8 :WINDow [1] 2 3 4 :TRACe:X[:SCALe]:COUP le?
Example:	:DISP:EVM3:WIND2:TRAC:X:COUP 0 :DISP:EVM3:WIND2:TRAC:X:COUP?

3.3.10 Trace/View

Select a measurement view from the following:

- **I/Q Measured Polar:** Sets the view to display an I/Q measured polar vector constellation and numeric results.
- **I/Q Error (Quad-view):** Divides the screen into four quadrants displaying magnitude error, phase error, error Vector Magnitude (EVM) and a summary of numeric results.
- **Eye (Quad-view):** Divides the screen into four quadrants displaying the eye I diagram, the eye Q diagram, the I/Q measured polar vector constellation, and a summary of the numeric results.
- **FSK Error (Quad-view):** Divides the screen into four quadrants displaying FSK error, FSK error spectrum, FSK measured time and a summary of the numeric results.
- **Numeric Results:** Sets the view to display all the numeric results related with the radio standard or modulation format.
- **Demod Bits:** Divides the screen into three windows displaying graphs of EVM vs. Time, the I/Q measured polar vector constellation, and a listing of the demodulated bits.
- **Error Vector Spectrum (Quad View):** Divides the screen into four quadrants displaying the RF Spectrum graph, the I/Q measured polar vector constellation, the Error Vector Spectrum, and the I/Q Reference Polar Vector graph.
- **Equalizer (Quad View):** Divides the screen into four quadrants displaying the Equalizer Channel Response (Magnitude) graph, the Equalizer Impulse Response graph, the Channel Response (Phase) graph, and a summary of the phase and magnitude errors.

Key Path:	Trace/View
Factory Preset	I/Q Measured Polar
State Saved:	Saved in instrument state.
Remote Command:	:DISPlay:EVM:VIEW POLar IQError EYE FSKError NRESults DBITs EVSpectrum EQUalizer :DISPlay:EVM:VIEW?
Example:	:DISP:EVM:VIEW EYE :DISP:EVM:VIEW?

3.4 SCPI only operations

3.4.1 Trig Error Offset

Returns the external trigger error offset from event to point zero in seconds.

Dependencies/Couplings None.

Remote Command [:SENSe]:EVM:WBIF:TRIGger:EOFFset?

Example :EVM:WBIF:TRIG:EOFF?

3.4.2 SCPI Result Table

:CONFigure:EVM

:INITiate:EVM

:FETCh:EVM [n] ?

:READ:EVM [n] ?

:MEASure:EVM [n] ?

n	Results Returned
0	Collected I/Q trace - Returns raw I/Q trace data captured by the instrument, as a data array of comma-separated trace points in volts. The I-values are listed first in each pair, using the 0 through even-indexed values. The Q-values are the odd-indexed values. The X-axis unit of this trace is seconds.

<p>1 (default value)</p>	<p>Returns 58 comma-separated floating point (except where stated otherwise) numbers, in the following order. Result value – 999 is returned for invalid. Results returned are based on the modulation format selected by the user.</p> <p>“Avg” means the average of the individual rms measurements when averaging is on.</p> <p>“Max” means the maximum of the individual rms measurements.</p> <ol style="list-style-type: none"> 1. RMS EVM Avg has units of percent. The calculation is based on the composite of the phase error and magnitude error, between the measured signal and the ideal signal. 2. RMS EVM Max 3. Peak EVM Avg has units of percent. The calculation is based on the composite of the phase error and magnitude error, between the measured signal and the ideal signal. 4. Symbol position of the Peak EVM Avg – an integer number of the symbol position where the last averaged peak EVM error is detected. 5. Peak EVM Max 6. Symbol position of the Peak EVM Max – an integer number of the symbol position where the maximum peak EVM error is detected. 7. RMS Magnitude Error Avg has units of percent. This is the rms error between the measured (compensated) magnitude and the ideal magnitude. 8. RMS Magnitude Error Max 9. Peak Magnitude Error Avg has units of percent. This is the peak error between the measured (compensated) magnitude and the ideal magnitude. 10. Symbol position of the Peak Magnitude Error Avg – an integer number representing the symbol position where the last averaged peak magnitude error was detected. 11. Peak Magnitude Error Max 12. Symbol position of the Peak Magnitude Error Max – an integer number representing the symbol position where the maximum peak magnitude error was detected. 13. RMS Phase Error Avg has unit of degree. This is the rms error between the measured (compensated) phase and the ideal phase. 14. RMS Phase Error Max 15. Peak Phase Error Avg has unit of degree. This is the peak error between the measured (compensated) phase and the ideal phase. 16. Symbol position of the Peak Phase Error Avg – an integer number representing the symbol position where the last averaged peak Phase error was detected. 17. Peak Phase Error Max <p>(Continued next page)</p>
--------------------------	--

<p>1 (default value)</p> <p>(Continued)</p>	<p>18. Symbol position of the Phase Error (peak) Max – an integer number representing the symbol position where the maximum peak Phase error was detected.</p> <p>19. Frequency Error Avg of the measured signal, has units of Hz. This is based on the linear best fit of the uncorrected measured phase. If averaging is on, this is the average of the individual frequency error measurements.</p> <p>20. Frequency Error Max</p> <p>21. I/Q Offset Avg has unit of dB. This is the dc error offset of I/Q, from the origin. If averaging is on, this is the average of the individual carrier feed-through measurements.</p> <p>22. I/Q Offset Max</p> <p>23. Quadrature Skew Avg has unit of degree. This shows how precisely I/Q channels of a transmitter operate at 90 degrees to each other.</p> <p>24. Quadrature Skew Max</p> <p>25. I/Q Gain Imbalance Avg has unit of dB. This compares the gain of the I signal with the gain of the Q signal, by division of I by Q. If averaging is on, this is the average of the individual measurements.</p> <p>26. I/Q Gain Imbalance Max</p> <p>27. Amplitude Droop Error Avg has unit of dB/symbol. This is the linear best fit of the amplitude slope of the measured signal.</p> <p>28. Amplitude Droop Error Max</p> <p>29. Rho Avg has no unit. This is computed by comparing the normalized correlated power between the measured signal and the reference signal and is designated as the waveform quality factor.</p> <p>30. Rho Min. Minimum value is provided for Rho because being opposite to other results, higher value means better signal.</p> <p>31. 95% EVM is for EDGE only and has unit of percent. This is the EVM below which 95% of the individual symbol EVMs occur.</p> <p>32. FSK Error Avg has unit of percent. This is computed by comparing the FSK reference signal with the FSK measured signal at the symbol locations.</p> <p>33. FSK Error Max</p> <p>34. Peak FSK Error Avg has unit of percent. This is peak error at the symbol locations between the FSK reference signal with the FSK measured signal.</p> <p>35. Symbol position for Peak FSK Error Avg– an integer number representing the symbol position where the last peak FSK error was detected.</p> <p>36. FSK Peak Error Max</p> <p>37. Symbol position for FSK Peak Error Max – an integer number representing the symbol position where the maximum peak FSK error was detected.</p> <p>38. Frequency Carrier Offset Avg has unit of Hz. This shows the carrier frequency-error relative to the analyzer's center frequency.</p> <p>(Continued next page)</p>
---	--

<p>1 (default value) (Continued)</p>	<p>39. Frequency Carrier Offset Max</p> <p>40. Frequency Deviation Avg has unit of Hz. This shows the frequency difference at outermost symbol locations relative to the detected carrier frequency.</p> <p>41. Frequency Deviation Max</p> <p>42. Signal Noise Ratio Avg has unit of dB. Signal to Noise Ratio (Message Error Rate) is reported for QAM and QPSK demodulation formats. It is the signal-to-noise ratio, where signal is the average symbol power of the transmitted waveform, and noise power includes any term that causes the symbol to deviate from its ideal state position</p> <p>43. Signal Noise Ratio Min</p> <p>44. Trace Time Sample is a floating-point number (in seconds) of the time between samples for the Collected I/Q Trace (fetch0). A reciprocal number of it is the sample rate (in Hz).</p> <p>45. Collected I/Q Vector Trace Length is an integer number (in units of samples) representing the number of samples returned by the current Corrected I/Q Trace (fetch0) (i.e. this number divided by 2 represents the number of sample pairs in the trace)</p> <p>46. Frequency Deviation Min.</p> <p>47. RF Power Avg. is a floating-point number (in dBm) of RF power inside IFBW.</p> <p>48. RF Power Max.</p> <p>49. Offset RMS EVM Avg has units of percent. Calculation method is same as RMS EVM except shifting Q 1/2 symbol. This result is available only when OQPSK is selected.</p> <p>50. Offset RMS EVM Max</p> <p>51. N/A</p> <p>52. N/A</p> <p>53. N/A</p> <p>54. N/A</p> <p>55. RBW of RF Spectrum has units of hertz. RBW of this measurement is calculated from the equivalent noise bandwidth.</p> <p>56. RBW of Error Vector Spectrum has units of hertz. RBW of this measurement is calculated from the equivalent noise bandwidth.</p> <p>57. N/A</p> <p>58. Data Validity is an integer value which indicates whether this result set is valid. When data is valid, 1 is returned. If not, 0 is returned.</p>
---	---

2	EVM Trace – Returns a trace of the error vector magnitude (EVM), as comma-separated trace points in percent. The first value is the symbol 0 decision point. The trace is interpolated for the currently selected points/symbol displayed on the front panel. The number of trace points depends on the current measurement interval setting. The X-axis unit of this trace is Symbols.
3	Mag Error Trace – Returns a trace of the magnitude error, as comma-separated trace points in percent. The first value is the symbol 0 decision point. The trace is interpolated for the currently selected points/symbol displayed on the front panel. The number of trace points depends on the current measurement interval setting. The X-axis unit of this trace is Symbols.
4	Phase Error Trace - Returns a trace of the phase error, as comma-separated trace points in degree. The first value is the symbol 0 decision point. The trace is interpolated for the currently selected points/symbol displayed on the front panel. The number of trace points depends on the current measurement interval setting. The X-axis unit of this trace is Symbols.
5	Error Vector Spectrum - Returns a trace of the Error Vector Spectrum data, as comma-separated trace points. The trace is in unit of dB. The number of trace points depends on the current measurement interval setting. The X-axis unit of this trace is Hertz.
6	I/Q Measured Vector trace - Returns a trace of the I/Q Measured data, as comma-separated trace points normalized in the manner of IQ Scaling setting. The trace is interpolated for the currently selected points/symbol displayed on the front panel. The number of trace points depends on the current measurement interval setting. The I values are listed first in each pair, using the 0 through even-indexed values. The Q values are the odd-indexed values. The X-axis unit of this trace is Symbols.
7	I/Q Reference Vector trace - Returns a trace of the I/Q Reference data, as comma-separated trace points normalized in the manner of IQ Scaling setting. The trace is interpolated for the currently selected points/symbol displayed on the front panel. The number of trace points depends on the current measurement interval setting. The I-values are listed first in each pair, using the 0 through even-indexed values. The Q-values are the odd-indexed values. The X-axis unit of this trace is Symbols.
8	Equalizer Impulse Response - Returns a trace of the Equalizer Impulse Response data, as comma-separated trace points. The number of trace points depends on the current measurement interval and Points/Symbol setting. The real values are listed first in each pair, using the 0 through even-indexed values. The imaginary values are the odd-indexed values. The X-axis unit of this trace is Symbols.
9	Equalizer Channel Frequency Response (Magnitude) - Returns a trace of the Equalizer Channel Frequency Response Magnitude data, as comma –separated trace points. The X-axis unit of this trace is Hertz.
10	Equalizer Channel Frequency Response (Phase) - Returns a trace of the Equalizer Channel Frequency Response Phase data, as comma –separated trace points. The X-axis unit of this trace is Hertz.

11	N/A
12	FSK Error Trace - Returns a trace of the FSK Error Trace data, as comma-separated trace points The trace is in % when FSK Normalize is ON and in Hz when FSK Normalize is OFF. The trace is interpolated for the currently selected points/symbol displayed on the front panel. The number of trace points depends on the current measurement interval setting. The X-axis unit of this trace is Symbols.
13	FSK Error Spectrum- Returns a trace of the FSK Error Spectrum data, as comma-separated trace points The trace is in unit of dB when FSK Normalize is ON and in unit of dBHz when FSK Normalize is OFF. The number of trace points depends on the current measurement interval setting. The X-axis unit of this trace is Hertz.
14	Limit Check Results – Returns 2 scalar values of the pass/fail (0=passed, or 1=failed) results determined by testing the RMS EVM and the Frequency Error. If limit check for each result is turned off, returns 0. Test result of EVM Test result of Frequency Error
15	FSK Meas Time – Returns a trace of the FSK meas time, as comma-separated trace points. When FSK Normalize is ON, the trace is normalized by the measured deviation. When FSK Normalized is OFF, the trace is in unit of Hz. The first value is the symbol 0 decision point. The trace is interpolated for the currently selected points/symbol displayed on the front panel. The number of trace points depends on the current measurement interval setting. The X-axis unit of this trace is Symbols.
16	FSK Ref Time– Returns a trace of the FSK Ref time, as comma-separated trace points. When FSK Normalize is ON, the trace is normalized by the measured deviation. When FSK Normalized is OFF, the trace is in unit of Hz. The first value is the symbol 0 decision point. The trace is interpolated for the currently selected points/symbol displayed on the front panel. The number of trace points depends on the current measurement interval setting. The X-axis unit of this trace is Symbols.
17	Averaged Error Vector Spectrum Returns a trace of the Averaged Error Vector Spectrum data, as comma-separated trace points in unit of dB. The number of trace points depends on the current measurement interval setting. The X-axis unit of this trace is Hertz.
18	Averaged FSK Spectrum - Returns a trace of the Averaged FSK Error Spectrum data, as comma-separated trace points The trace is in unit of dB when FSK Normalize is ON and in unit of dBHz when FSK Normalize is OFF. The number of trace points depends on the current measurement interval setting. The X-axis unit of this trace is Hertz.
19	Demod Bits - Returns a trace of the Demod Bits data, as comma-separated trace. The number of trace points is equal to Meas Interval. The data is in decimal format. The X-axis unit of this trace is Seconds.
20	N/A

21	Trace X Info - Returns a trace of the Trace X Info data, as comma-separated trace. This trace returns start and delta values of X axis of each trace. The X start values are listed first in each pair, using the 0 through even-indexed values. The X delta values are the odd-indexed values. The number of trace points is 21*2 = 24. Unit of each trace is described in each row of this table or is summarized in Table 3-4, “N=21 Trace X Info,” on page 186
22	N/A
23	RF Spectrum - Returns a trace of the RF Spectrum data, as comma-separated trace points in unit of dBm. The number of trace points depends on the current measurement interval setting.
24	Averaged RF Spectrum - Returns a trace of the Averaged RF Spectrum data, as comma-separated trace points in unit of dBm. The number of trace points depends on the current measurement interval setting.

Table 3-4 N=21 Trace X Info

n	Trace Name	X-Axis Units
0	Collected I/Q trace Second	
1	Numeric Results N/A	
2	EVM TraceSymbol	
3	Mag Error TraceSymbol	
4	Phase Error TraceSymbol	
5	Error Vector SpectrumHz	
6	I/Q Measured Vector trace Symbol	
7	I/Q Reference Vector trace Symbol	
8	Equalizer Impulse Response Symbol	
9	Equalizer Channel Frequency Response (Magnitude)Hz	
10	Equalizer Channel Frequency Response (Phase)Hz	
11	N/AN/A	
12	FSK Error TraceSymbol	
13	FSK Error SpectrumHz	
14	Limit Check ResultsN/A	
15	FSK Meas TimeSymbol	

Table 3-4 N=21 Trace X Info

n	Trace Name	X-Axis Units
16	FSK Ref TimeSymbol	
17	Averaged Error Vector SpectrumHz	
18	Averaged FSK SpectrumHz	
19	Demod BitsSecond	
20	N/AN/A	
21	Trace X InfoN/A	
22	N/AN/A	
23	RF SpectrumHz	
24	Averaged RF SpectrumHz	

3.4.3 Averaging

When averaging is turned on in the measurement, all scalar measurement results shall be averaged together from one trigger cycle to the next. The Max field will show the maximum result since the start of averaging period and the Avg field will show the mean of the results since the start of the averaging period. This includes rms/peak EVM, carrier frequency error, rms/peak phase error, rms/peak magnitude error, I/Q Offset, quadrature error, I/Q gain imbalance, Amplitude Droop, Rho and 95% EVM. There are 2 types of traces in Modulation analysis, Average and Non-Average trace. Non-Average trace data always show the result from the latest captured input signal, and Average trace data show averaged result trace which are calculated obeying Average Mode and Trace Average Type settings. When averaging is off, Max will hold the peak and the Avg field will show the current result. Averaging will adhere to the general method explained in the Mode Section on Averaging.

4 Concepts

This chapter describes the concepts and theory of basic digital modulation, cellular modulation, and emerging communications. Also covered are the modulation formats that can be demodulated by PSA Option 241, and how measurements are performed by the instrument. A list of related Agilent documents is provided for further reference.

Introduction

This chapter provides a variety of digital modulation concepts to help you to better understand the features and measurements performed by PSA Option 241.

[“Introduction to Digital Modulation” on page 191](#), explains the difference between analog and digital modulation. The advantages of digital modulation are given as well as the methods by which a digital baseband signal is modulated onto an RF carrier. The following three sections will build on this introduction to digital modulation.

[“Digital Modulation Format Standards” on page 203](#), contains a general description of the modulation format families. These are, phase shift keying (PSK), frequency shift keying (FSK), minimum shift keying (MSK) and quadrature amplitude modulation (QAM). Within each family, examples of typical I/Q patterns, Spectral diagrams and default values are given for the individual formats. Bit state diagrams for FSK, PSK, QAM and DVB QAM are provided at the end of this section.

[“Communication System Formats” on page 238](#) covers the predefined communication systems. These are, GSM, EDGE, W-CDMA, cdma2000, Bluetooth, NADC, PDC, PHS, IS-95, TETRA, APCO25 phase1, VDL Mode 3, and ZigBee 2450 MHz. A general description of each communication system is given together with examples of typical I/Q patterns, Spectral diagrams and default values.

[“Measurements on Digital RF Communications Systems” on page 278](#), describes how the PSA option 241 analyzes digital modulation sources. After reviewing digital modulation fundamentals, typical sources of modulation errors are presented. This section ends with a description of measurement displays and what to look for in determining the quality of a digital modulation measurement.

[“References” on page 308](#) are given along with a list of related Agilent documents for further reading.

Introduction to Digital Modulation

Why Choose Digital Instead of Analog Modulation?

The RF spectrum must be shared, yet every day there are more users for that spectrum, as demand for communications services increases. Digital modulation schemes have significant advantages over analog modulation schemes.

These are:

- more information capacity
- higher security
- compatibility with digital data services
- better quality communications

What is Digital Modulation?

Digital modulation is a term used in radio, satellite, and terrestrial communications to refer to modulation in which digital states (1's and 0's) are represented by the relative phase and/or amplitude of a carrier. In digital modulation, it is the baseband modulating signal that is in digital form. The original signal may be analog, e.g. voice, so it is converted to a bit stream prior to the modulation process. The amplitude, frequency, or phase of the carrier is modulated in direct proportion to the amplitude of the modulating (baseband) signal, usually just two values, example 0 and 1.

Figure 4-1 shows the effect of a digital baseband modulating signal on an RF carrier using four methods of digital modulation. The digital baseband signal seen at the top as a 1010 bit pattern. The upper three waveforms show the effects of this baseband bit pattern modulating the amplitude, frequency and phase of the carrier waveform. These waveforms could also be easily achieved using standard analog modulation techniques.

The fourth waveform shows the effects of this baseband bit pattern modulating the amplitude and phase of the carrier at the same time. In theory, by combining waveforms 1 and 3, this waveform could also have been created using analog modulation techniques. However, this type of waveform is difficult to generate, and especially difficult to detect using analog modulation.

In digital modulation, instead of using analog modulation techniques, a fundamentally different modulation technique is used. If a double balanced mixer is used, waveform 4 becomes easy to produce. This form of modulation is referred to as I/Q, Vector or complex modulation. For consistency, the term I/Q modulation will be used throughout this chapter.

In I/Q modulation the baseband modulating signal is separated into two components, an I and a Q component. The fourth waveform in Figure 4-1 is easy to generate and detect using the techniques of I/Q modulation. Using the I/Q modulator, the amplitude and the phase of the carrier can be modulated together or independently.

Figure 4-1 Modulation

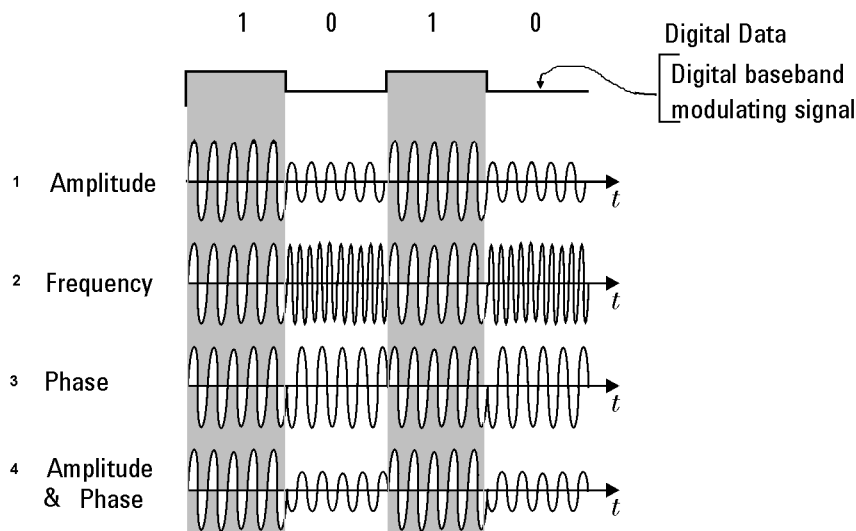

In digital modulation, the information is contained in the relative phase and amplitude of the carrier signal.

I/Q modulation can best be presented in the I/Q plane or I/Q diagram as shown in Figure 4-2.

In most digital communication systems, the frequency of the carrier is fixed so only phase and magnitude need to be considered.¹ The unmodulated carrier is the phase and frequency reference, and the modulated signal is interpreted relative to the carrier. Notice in Figure 4-2 that the unmodulated carrier reference is 0° , along the I axis.

In Figure 4-2 the phase and magnitude of the modulated carrier can be represented in rectangular or polar coordinates as a discrete point in the I/Q plane. In rectangular coordinates, “I” represents the in-phase (phase reference) component and “Q” represents the quadrature (90° out of phase) component. Using polar coordinates in this example, the phase angle is 135° and the amplitude is 1 as seen by the magnitude vector.

1. The carrier frequency of the GSM digital communication system does change, and GSM is in widespread use.

Figure 4-2 I/Q Plane or I/Q Diagram

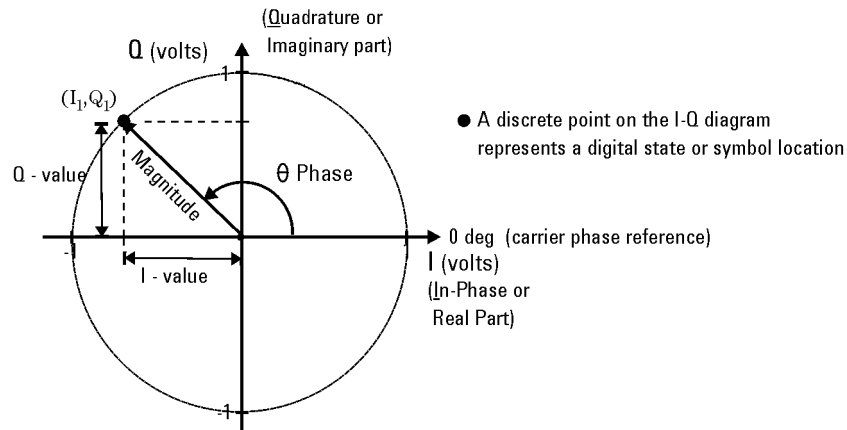

Digital modulation refers to modulation in which digital states are represented by relative phase and amplitude of the carrier. The phase and magnitude can be represented in polar or rectangular coordinates as a discrete point in the I-Q plane.

Depending on the particular format or application, digital modulation may modify both amplitude and phase simultaneously. I/Q modulation is a very powerful scheme because it can be used to generate any arbitrary carrier phase and magnitude. Each value of magnitude and phase has a corresponding point in the I/Q plane.

The location of each point is of critical importance as it represents a digital code. Each discrete point is called a symbol as it symbolizes a unique digital code. The symbol points are not random; their exact position on the I/Q plane is specified by the modulation format being used. Fortunately, there are a limited number of digital modulation formats to become familiar with.

In any given digital modulation format, the signal moves between the symbols arriving at a symbol at the decision point on the symbol clock. Each communications format standard (application) uses a particular modulation format. There are four main modulation format categories. All four are variations of the common I/Q Modulation and will be explained in more detail later, See [“Digital Modulation Format Standards” on page 203](#).

- In phase shift keying (PSK), the digital modulating signal changes the carrier at every baseband signal change. By simultaneously changing the carrier phase, symbols can be represented and transmitted. See [“Phase Shift Keying \(PSK\) Concepts” on page 205](#)
- In Frequency shift keying (FSK), the frequency of the carrier changes slightly for every symbol change. Different frequencies can be used to represent different symbols. See [“Frequency Shift Keying \(FSK\) Concepts” on page 215](#)
- Minimal shift keying (MSK) is a specific form of FSK. See [“Minimum Shift Keying \(MSK\) Concepts” on page 218](#)

- Quadrature amplitude modulation (QAM) combines amplitude and phase changes. Each quadrant of the I/Q plane can have several symbols allocated to it. Hence 16QAM, 32QAM etc. See “[Quadrature Amplitude Modulation \(QAM\) Concepts](#)” on page 221

PSK examples

Binary phase shift keying (BPSK) is the most simple form of phase shift keying. The carrier amplitude and frequency remain constant while the phase of the carrier is switched 180 degrees or not depending on the symbol being transmitted.

Figure 4-3

BPSK example

Constellation Diagram

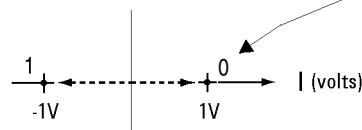

In binary phase shift keying (BPSK) there are two symbols, 0 and 1. Both are on the I axes. There is no Q axes component.

Symbol Mapping to I Voltages

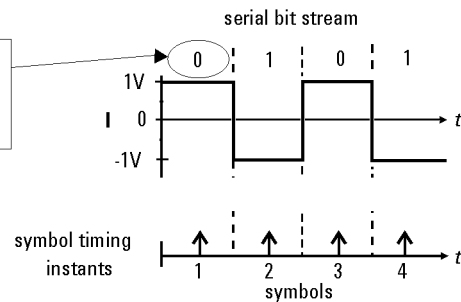

The next example shows another member of the PSK format, quadrature phase shift keying (QPSK). [Figure 4-4](#) shows four symbol states are shown, 00, 01, 10 and 11. There is one symbol in each quadrant. The symbol state shown previously in [Figure 4-2](#) would be in the top left quadrant, the 01 symbol in the [Figure 4-4](#). All symbols are of equal importance, no individual symbol is more important than any other symbol. The I/Q voltages drive movement around the constellation diagram.

Figure 4-4

Example 1, constellation diagrams and symbols

Constellation Diagram

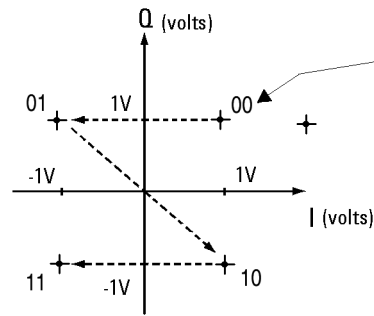

state: 00
symbol: 1
I = 1 v
Q = 1 v

Symbol Mapping to IQ Voltages

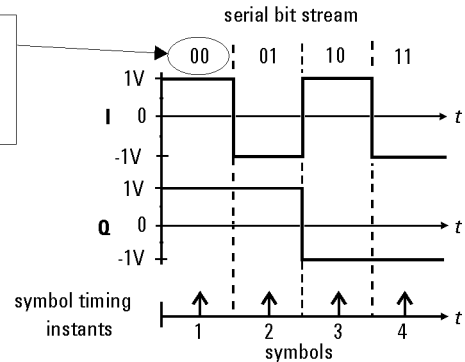

Each position or state in the constellation diagram represents a specific bit pattern (symbol) and symbol time.

Also, from the QPSK constellation diagram in [Figure 4-4](#), there is a symbol path from any symbol to any of the other three symbols on the I/Q plane. Notice in the constellation diagram there is a probability of one chance in four that the signal trajectory will go through the origin. See [“Effects Of Going Through The Origin”](#) on page 199.

NOTE

In this example the voltage ranges of both I and Q axes are plus to minus one volt. These values will vary with individual systems and formats. The origin is at 0 volts for both axes.

QPSK is a four-symbol system, each symbol representing two data bits.

Orthogonality

The baseband digital information is separated into two independent components: the I (in-phase) and Q (quadrature) components.

The most important characteristic of I and Q components is that they are independent components (orthogonal). Orthogonality means at right angles. The Q signal has no I component in it so that any variation in the I signal has no effect on the Q signal and vice versa.

QAM example

The example in [Figure 4-5](#) is a member of the QAM family, 16 QAM. The QPSK example had one symbol per quadrant. In this example, 16 QAM there are four symbols per quadrant, making a total of sixteen possible symbols. The symbol state shown earlier in [Figure 4-2](#) would again be in the top left quadrant in the [Figure 4-5](#). In this 16 QAM format scheme, it would be the symbol that represents 0011.

The constellation diagram in [Figure 4-5](#), shows the path of a four symbol serial bit stream, 0100, 0001, 1101, 0010. The symbol-mapping

graphic in Figure 4-5 shows the I/Q voltages and timing used to create the four symbols.

Notice that the four symbols per quadrant have been achieved by having four levels of I/Q voltage, +1, +1/2, -1/2 and -1volts. The QAM format can be expanded to 64 symbols per quadrant or more. It is important to understand that, for given I/Q voltages, the more symbols per quadrant, the smaller the changes in I/Q voltage have to be to generate individual symbols.

Figure 4-5

Constellation Diagrams and Symbols

Constellation Diagram

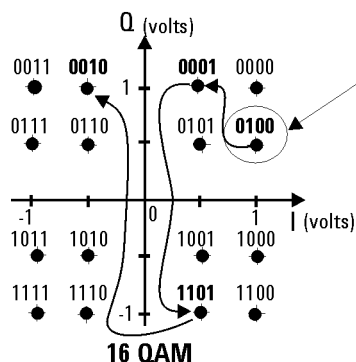

Symbol Mapping to IQ Voltages

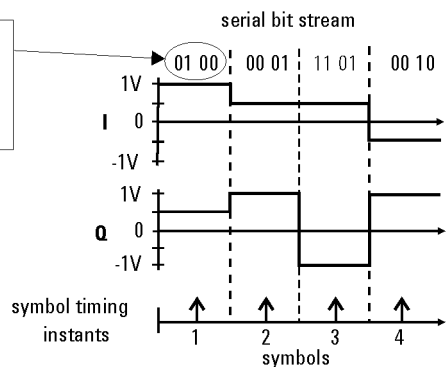

Each position or state in the constellation diagram represents a specific bit pattern (symbol) and symbol time.

Symbol Rate

The rate at which the carrier moves between points in the constellation is called the symbol rate. The more constellation states that are used, the lower the required symbol rate for a given bit rate. The symbol rate is important because it sets the bandwidth required to transmit the signal.

Bandwidth

The lower the symbol rate, the lower the bandwidth required for transmission. For example, the 16QAM shown in Figure 4-6 uses 4 bits/symbol. If the radio transmission rate is 16 Mbps, then the symbol rate = 16 (Mbps) / 4 bits or 4 MHz. This provides a symbol rate that is one-fourth the bit rate and a more spectrally efficient transmission bandwidth (4 MHz vs. 16 MHz). The BPSK modulation format shown in Figure 4-6 uses 1 bit per symbol and a transmission bandwidth of 16 MHz.

Figure 4-6

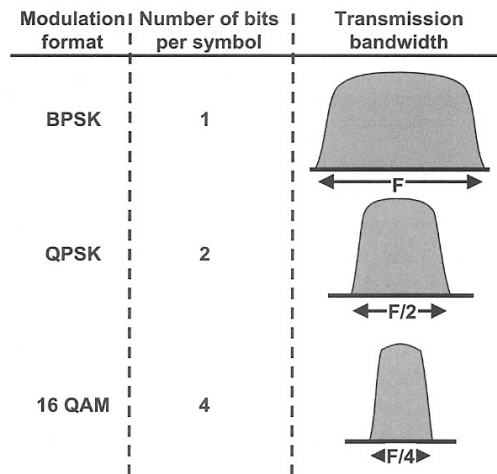

Filtering

Figure 4-1 on page 192 shows rapid changes in the carrier due to the rapid transitions in the modulating bit stream. The result is a spectrum essentially the same as that produced by a pulsed carrier which theoretically is infinitely wide. Too wide a spectrum (bandwidth) cannot be tolerated because of interference with adjacent carriers. To prevent this, filtering is introduced.

Well designed filtering allows the transmitted bandwidth to be significantly reduced, without losing the content of the digital data. This improves the spectral efficiency of the signal.

Figure 4-7 shows the bandwidth required to successfully reproduce three pulse shapes. The top example is a square pulse that has very fast edges creating the square shape. These fast edges require the presence of high frequencies in order to happen. This can be seen in the pulse bandwidth required to successfully reproduce the square pulse. Notice also, in the other two examples in Figure 4-7 that as the edges of the square pulse become slower, the pulse bandwidth required becomes smaller. A filter designed to pass the bandwidth of the bottom example in Figure 4-7 would allow the pulse shape corresponding to it. This pulse shape still contains all the information of the original square pulse shape. However, it is important to understand that in the bottom example the I/Q voltage is only at the symbol or decision point for a short time. As opposed to the top example where it is there longer.

Figure 4-7 The Relationship of Pulse Shape and Bandwidth

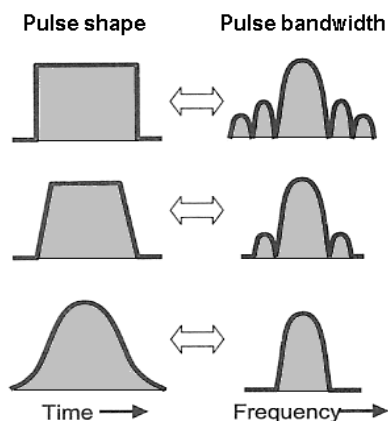

Again there are trade-offs; filtering reduces the bandwidth occupied for a digital pulse stream. Filtering also reduces interference because it reduces the tendency of one signal or one transmitter to interfere with another, such as in a Frequency-Division-Multiple-Access (FDMA) system. The effect of filtering can be seen on a QPSK signal in [Figure 4-8](#).

Figure 4-8 The relationship Between Filter Shape and I/Q Transitions

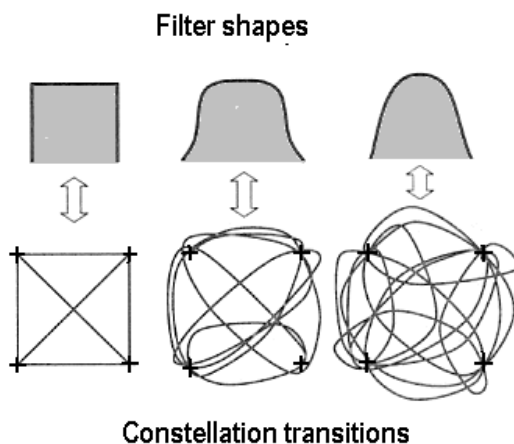

[Figure 4-9](#) shows the effects of filtering on the same serial bit stream used in the QPSK example discussed earlier. Compare this to [Figure 4-4](#); the serial bit stream transitions are now more rounded, taking longer to change from one state to another. Too much filtering can reduce modulation quality by preventing the signal from reaching the constellation point. See “[Modulation quality measurements](#)” on [page 286](#).

Figure 4-9 I/Q diagram with filtering applied

Constellation Diagram

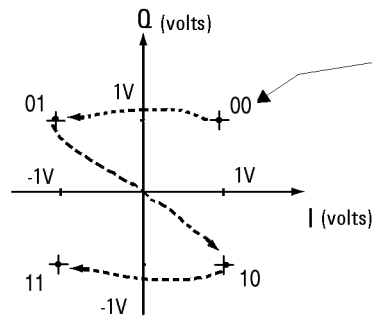

state: 00
symbol: 1
I = 1 v
Q = 1 v

Symbol Mapping to IQ Voltages

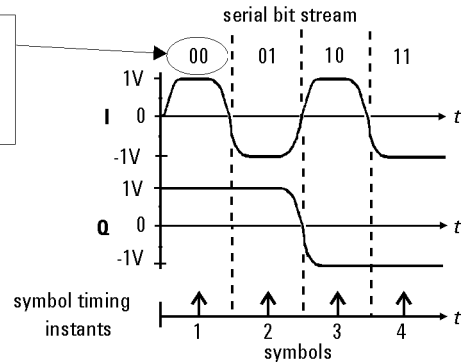

Each position or state in the constellation diagram represents a specific bit pattern (symbol) and symbol time.

On the receiver end, reduced bandwidth brought about by filtering improves sensitivity because more noise and interference are rejected.

There are several different varieties of filters used. The most common are

- Nyquist or raised cosine
- Square-root raised cosine
- Gaussian filters

Effects Of Going Through The Origin

The example shown in [Figure 4-9](#) has three symbol changes. Symbol changes 1 and 3 have only one I/Q bit change, either I or Q. However, in symbol change 2, both I and Q change and the signal trajectory passes through the origin. The origin represents 0V carrier magnitude (I/Q value of 0,0).

Why is it necessary to worry about the signal passing close to the amplifier origin? The problem lies in potential nonlinearities in the amplifier circuits. A signal, which changes amplitude over a very large range, will exercise these nonlinearities to the fullest extent. These nonlinearities will cause distortion products. In continuously modulated systems they will cause “spectral regrowth” or wider modulation sidebands (a phenomenon related to intermodulation distortion). For this reason, other modulation formats have been developed for applications where spectral regrowth is a problem. See [“Differential Modulation Concepts” on page 209](#).

Spectral regrowth does not automatically result from trajectories that pass through or near the origin. If the amplifier and associated circuits are perfectly linear, the spectrum (spectral occupancy or occupied bandwidth) will be unchanged.

Transmitting the Digital Signal

Each digital modulation format has advantages and disadvantages, making it more or less suitable for different communication applications. Applications include satellite, cellular communication, microwave digital radio and deep space telemetry.

Generally for digital modulation, an I/Q modulator is used to mix the digital baseband signal with the RF carrier¹. In the process of modulation - transmission - demodulation errors or impairments can be introduced to the baseband signal, (see “Interpreting Measurement results”)

Using an I/Q demodulator, demodulating the signal is straightforward in principle. The I/Q modulator will be examined next, to understand how the I/Q signals are combined with the RF carrier signal. It is these modulated RF signals that PSA option 241 has been developed to analyze. See “Measurements on Digital RF Communications Systems” on page 278.

I/Q Modulator

The I/Q modulator is the device used in digital communications to generate I/Q modulation. The I/Q modulator puts the encoded digital I and Q baseband information onto the carrier (Figure 4-10).

The two modulators shown in Figure 4-10 are double balance mixers (DBM). The DBM is in effect a continuously variable attenuator. With a DBM in both the I and Q channels, complete control is possible over the magnitude and phase of the combined output of the I/Q modulator.

Figure 4-10

I/Q Modulator

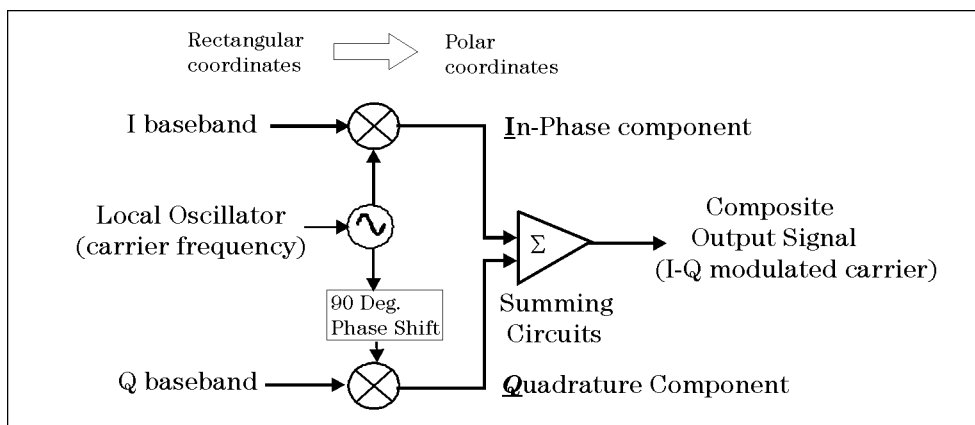

I-Q Modulator

The I/Q modulator receives the I and Q baseband signals as inputs and

1. BPSK does not have a Q component and GSM uses a different modulator.

mixes them with the same local oscillator (LO), which is up converted to the RF carrier frequency. The I information amplitude modulates the carrier producing the In-phase component. The Q information amplitude modulates a 90-degree (orthogonal) phase shifted version of the carrier producing the Quadrature component. These two orthogonal modulated carrier signals are summed together producing the composite I/Q modulated carrier signal. Fundamentally this can be viewed as a hardware (or software) implementation of a rectangular to polar coordinate conversion.

The main advantage of I/Q modulation is the ease of combining independent signal components into a single composite signal and later splitting the composite signal into its independent component parts.

System Multiplexing

Analog systems have the limitation of one user per carrier frequency. This limits the number of users able to use any given band of frequencies. However, the number of users can be increased for this same band of frequencies by combining digital modulation with multiplexing.

Two principal types of multiplexing (or “multiple access”) are TDMA (Time Division Multiple Access) and CDMA (Code Division Multiple Access). These are two different methods to add diversity to signals allowing different signals to be separated from one another. [Figure 4-11](#) shows how increased capacity can be achieved by multiplexing at the expense of increased complexity. The lowest diagram shows system capacity increasing from analog to digital to digital signal multiplexing. Several TDMA and CDMA systems will be discussed later.

As an example of multiplexing, consider yourself in a crowded room full of people talking to each other in groups. The fact that they are successfully talking shows that communication is possible. What makes it possible for them to communicate when each person’s voice and hearing frequency range is about the same? Individuals maybe “tuning in” their group’s voices because they are familiar, perhaps even speaking in a dialect or language that is closer to their own. The differences in pitch between group members also make it easier to listen. Or a person may use a pause in the general noise level of the room before conversing. Each of these techniques is used in digital signal multiplexing:

- Waiting for quiet time would be analogous to time division multiple access (TDMA).
- Language or dialect differences would be analogous to code division multiple access (CDMA).
- Pitch differences would be analogous to frequency division multiplexing (FDM).

Figure 4-11

The path from analog to digital signal multiplexing

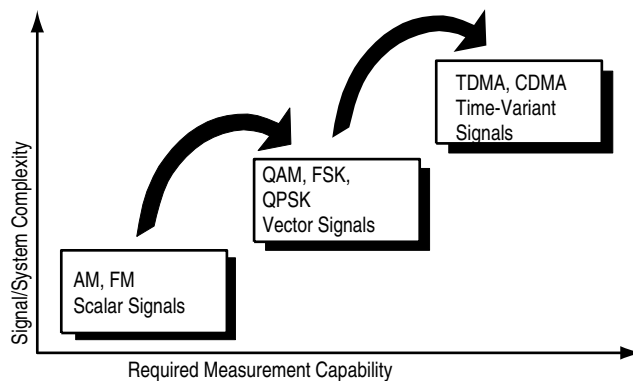

The next three sections will cover practical digital modulation formats, applications and measurement concepts.

Digital Modulation Format Standards

Introduction

The previous section introduced digital modulation and the concepts behind the individual formats. This section now introduces each format and provides details.

Modulation Formats and Applications

Table 4-1 shows modulation formats supported in PSA Option 241, grouped by the modulation format family.

To find out more about an individual format

- See “Phase Shift Keying (PSK) Concepts” on page 205.
- See “Differential Modulation Concepts” on page 209.
- See “Offset QPSK Modulation Concepts” on page 213.
- See “Frequency Shift Keying (FSK) Concepts” on page 215.
- See “Minimum Shift Keying (MSK) Concepts” on page 218.
- See “Quadrature Amplitude Modulation (QAM) Concepts” on page 221.

Families of Format and data sheets

Each modulation format has its separate data sheet showing constellation diagram, frequency spectrum occupied and a chart of default settings.

Table 4-1 Families of Digital Modulation Formats

Format Family	Modulation Format
PSK	BPSK
	QPSK
	8PSK
	DQPSK
	Pi/4 DQPSK
	D8PSK
	Offset QPSK
FSK	FSK 2, 4, 8 states

Table 4-1 Families of Digital Modulation Formats

Format Family	Modulation Format
MSK	MSK
QAM	16, 32, 64, 128, 256
DVB QAM	16, 32, 64, 128, 256
EDGE	EDGE

Applications

Table 4-2 shows the modulation formats for different applications used in wireless communications.

Table 4-2 Modulation Formats for Different Applications

Modulation Format	Application
MSK, GMSK	GSM, CDPD
BPSK	Deep space telemetry, cable modems
QPSK, Pi/4 DQPSK	Satellite, CDMA, NADC, TETRA, PHS, PDC, LMDS, DVDB-S, cable (return path), cable modems, TFTS, APCO25 phase1
OQPSK	CDMA, satellite
8PSK	Satellite, aircraft, telemetry pilots for monitoring broadband video systems
FSK, GFSK	DECT, paging, RAM mobile data, AMPS, CT2, ERMES, land mobile, public safety
2FSK	Bluetooth
16 QAM	Microwave digital radio, modems, DVB-C, DVB-T
32 QAM	Terrestrial microwave, DVB-T
64 QAM	DVB-C, modems, broadband set top boxes, MMDS
256 QAM	Modems, DVB-C (Europe), Digital Video (US)

Phase Shift Keying (PSK) Concepts

One of the simplest forms of digital modulation is binary or Bi-Phase Shift Keying (BPSK). One application where this is used is for deep space telemetry. The phase of a constant amplitude carrier signal moves between zero and 180 degrees. On an I/Q diagram, the I state has two different values. There are two possible locations in the constellation diagram, so a binary one or zero can be sent. The bit rate is one bit per symbol.

A more common type of phase modulation is Quadrature Phase Shift Keying (QPSK). It is used extensively in applications including CDMA (Code Division Multiple Access) cellular service, wireless local loop, and DVB-S (Digital Video Broadcasting — Satellite). Quadrature means that the signal shifts between phase states which are separated by 90 degrees. The signal shifts in increments of 90 degrees from 45 to 135, -45, or -135 degrees. These points are chosen as they can be easily implemented using an I/Q modulator. Only two I values and two Q values are needed and this gives two bits per symbol. There are four states because $2^2=4$. It is therefore a more bandwidth-efficient type of modulation than BPSK, potentially twice as efficient.

Figure 4-12 Phase Shift Keying (PSK)

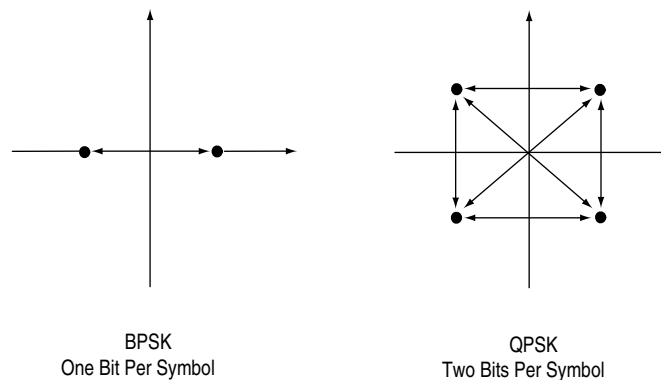

Types of PSK

- [“BPSK Modulation Characteristics” on page 206](#)
- [“QPSK Modulation Characteristics” on page 207](#)
- [“8PSK Modulation Characteristics” on page 208](#)
- [“DQPSK Modulation Characteristics” on page 210](#)
- [“ \$\pi/4\$ DQPSK Modulation Characteristics” on page 211](#)
- [“D8PSK Modulation Characteristics” on page 212](#)
- [“Offset QPSK Modulation Characteristics” on page 214](#)

BPSK Modulation Characteristics

Figure 4-13

BPSK Error Vector Spectrum (Quad View)

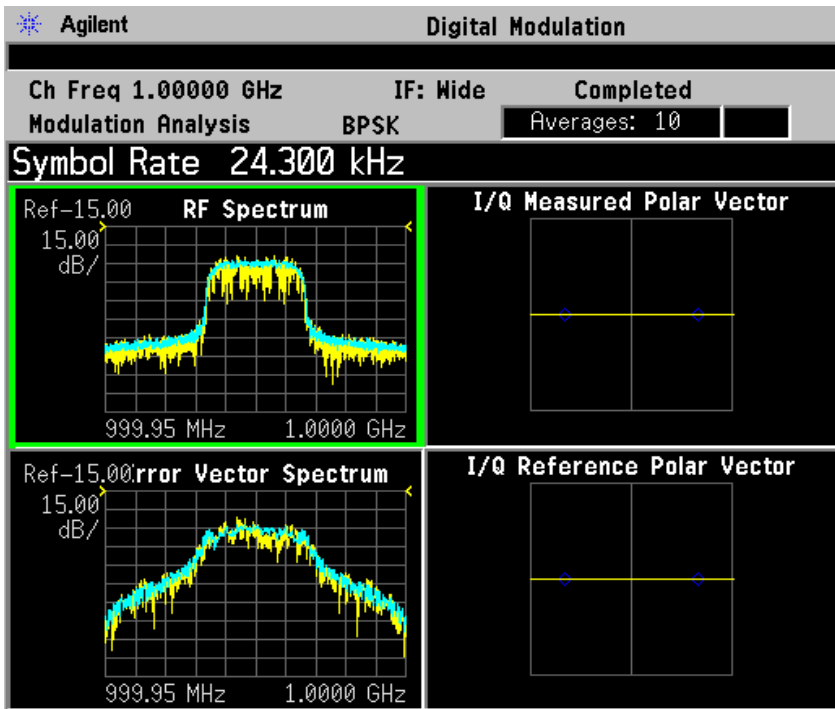

Figure 4-14

BPSK Meas Setup Table Example

Agilent Digital Modulation	
Ch Freq 1.00000 GHz	IF: Wide
Modulation Analysis BPSK	Completed
Averages: 10	
Modulation Format BPSK	
Modulation Format	BPSK
Meas Filter	Root Nyquist
Ref Filter	Nyquist
Alpha/BT	0.35
Symbol Rate	24.300 kHz
Meas Interval	256 symbols
IF Band Width	97.20 kHz
IF Band Width Mode	Auto
EQ Filter	Off
EQ Filter Length	5
EQ Convergence	1.000000
EQ Hold	Off
Sync Ptrn	0000
Average	On
Avg Number	10
Average Mode	Repeat
Trace Avg Type	RMS
FFT Window Type	Flat Top
Trig Source	Free Run
Carrier Lock	Normal
Sync	None
Burst Search Th.	-20.00 dB
Search Length	7.000000 ms
Sync Word Length	10 symbols
Sync Offset	0 symbols

QPSK Modulation Characteristics

Figure 4-15

QPSK Error Vector Spectrum (Quad View)- W-CDMA Signal

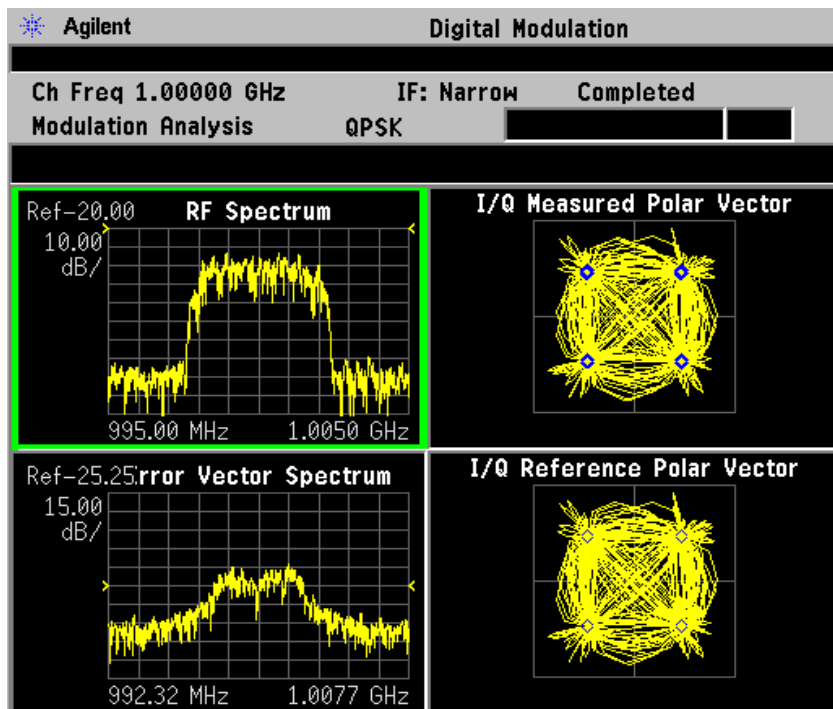

Concepts

Figure 4-16

QPSK Meas Setup Table Example

Agilent		Digital Modulation	
Ch Freq 1.00000 GHz		IF: Narrow	
Modulation Analysis		Completed	
Modulation Format QPSK			
Modulation Format	QPSK	Average	Off
Meas Filter	Root Nyquist	Avg Number	10
Ref Filter	Nyquist	Average Mode	Repeat
Alpha/BT	0.22	Trace Avg Type	RMS
Symbol Rate	3.840000 MHz	FFT Window Type	Flat Top
Meas Interval	256 symbols	Trig Source	Free Run
IF Band Width	10.00 MHz	Carrier Lock	Normal
IF Band Width Mode	Auto	Sync	RF Ampl
EQ Filter	Off	Burst Search Th.	-20.00 dB
EQ Filter Length	5	Search Length	666.700 μ s
EQ Convergence	1.000000	Sync Word Length	10 symbols
EQ Hold	Off	Sync Offset	0 symbols
Sync Ptrn	0000		

8PSK Modulation Characteristics

Figure 4-17

8PSK Error Vector Spectrum (Quad View)

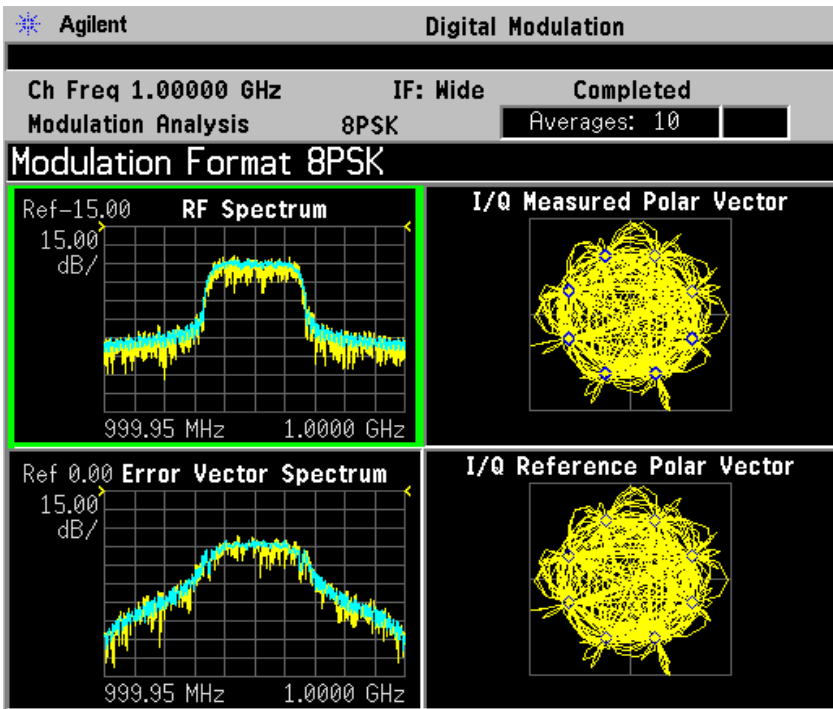

Figure 4-18

8PSK Meas Setup Table Example

Agilent Digital Modulation	
Ch Freq	1.00000 GHz
IF	Wide
Modulation Analysis	8PSK
Averages	10
Completed	
Modulation Format 8PSK	
Modulation Format	8PSK
Meas Filter	Root Nyquist
Ref Filter	Nyquist
Alpha/BT	0.35
Symbol Rate	24.300 kHz
Meas Interval	256 symbols
IF Band Width	97.20 kHz
IF Band Width Mode	Auto
EQ Filter	Off
EQ Filter Length	5
EQ Convergence	1.000000
EQ Hold	Off
Sync Ptrn	0000
Average	On
Avg Number	10
Average Mode	Repeat
Trace Avg Type	RMS
FFT Window Type	Flat Top
Trig Source	Free Run
Carrier Lock	Normal
Sync	None
Burst Search Th.	-20.00 dB
Search Length	7.000000 ms
Sync Word Length	10 symbols
Sync Offset	0 symbols

Differential Modulation Concepts

A variation to standard PSK is differential modulation as used in differential QPSK (DQPSK). Differential means that the information is not carried by the absolute state, it is carried by the transition between states. In some cases there are also restrictions on allowable transitions. This occurs in $\pi/4$ DQPSK where the carrier trajectory does not go through the origin. A DQPSK transmission system can transition from any symbol position to any other symbol position. The $\pi/4$ DQPSK modulation format is widely used in many applications including

CELLULAR

- NADC- IS-54 (North American digital cellular)
- PDC (Pacific Digital Cellular)

CORDLESS

- PHS (personal handyphone system)

TRUNKED RADIO

- TETRA (Trans European Trunked Radio)

The $\pi/4$ DQPSK modulation format uses two QPSK constellations offset by 45 degrees ($\pi/4$ radians). Transitions must occur from one constellation to the other. This guarantees that there is always a change in phase at each symbol, making clock recovery easier. The data is encoded in the magnitude and direction of the phase shift, not in the absolute position on the constellation. One advantage of $\pi/4$ DQPSK is that the signal trajectory does not pass through the origin, thus simplifying transmitter design. Another is that $\pi/4$ DQPSK, with root raised cosine filtering, has better spectral efficiency than GMSK, the other common cellular modulation type.

Figure 4-19

Differential Modulation

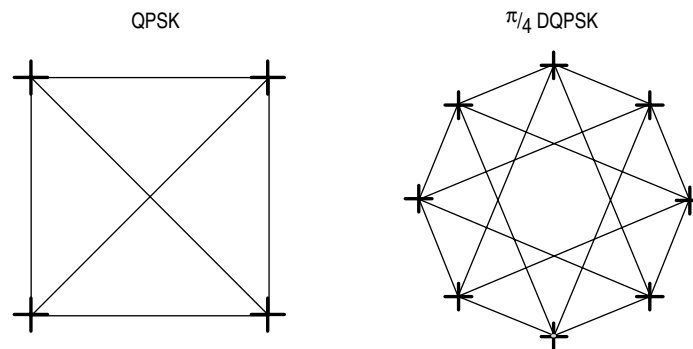

Both formats are 2 bits/symbol

DQPSK Modulation Characteristics

Figure 4-20

DQPSK Error Vector Spectrum (Quad-View)

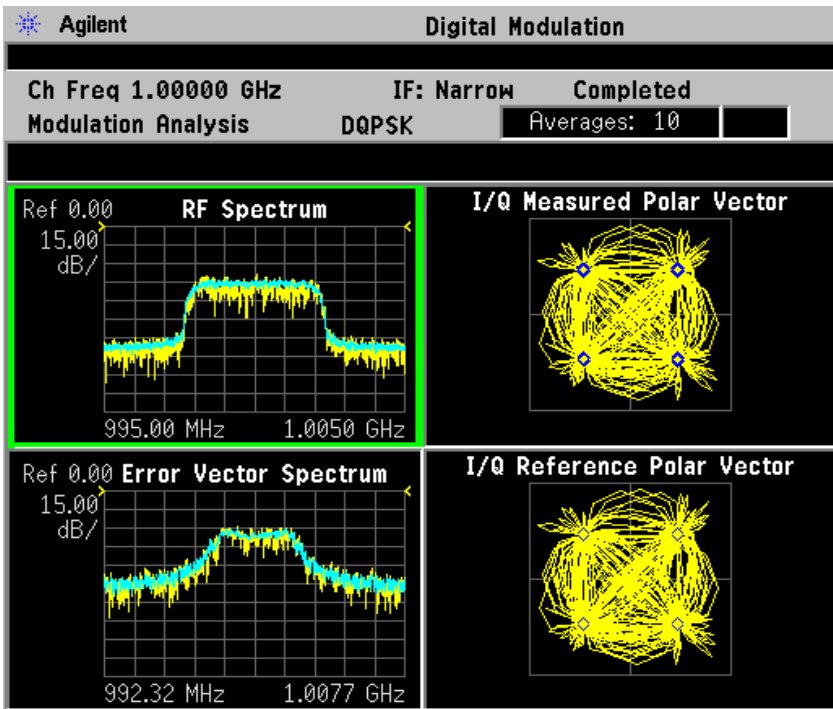

Figure 4-21

DQPSK Meas Setup Table Example

Agilent Digital Modulation	
Ch Freq 1.00000 GHz	IF: Narrow Completed
Modulation Analysis DQPSK	Averages: 10
Modulation Format DQPSK	
Modulation Format	DQPSK
Meas Filter	Root Nyquist
Ref Filter	Nyquist
Alpha/BT	0.22
Symbol Rate	3.840000 MHz
Meas Interval	256 symbols
IF Band Width	10.00 MHz
IF Band Width Mode	Auto
EQ Filter	Off
EQ Filter Length	5
EQ Convergence	1.000000
EQ Hold	Off
Sync Ptrn	0000
Average	On
Avg Number	10
Average Mode	Repeat
Trace Avg Type	RMS
FFT Window Type	Flat Top
Trig Source	Free Run
Carrier Lock	Normal
Sync	None
Burst Search Th.	-20.00 dB
Search Length	10.000000 ms
Sync Word Length	10 symbols
Sync Offset	0 symbols

$\pi/4$ DQPSK Modulation Characteristics

Figure 4-22

$\pi/4$ DQPSK Error Vector Spectrum (Quad-View)

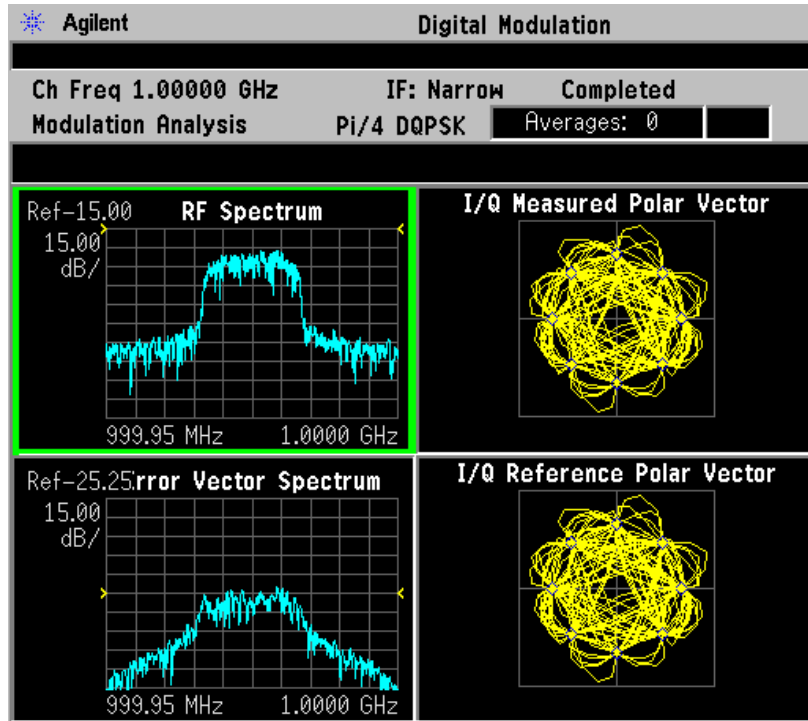

Concepts

Figure 4-23

$\pi/4$ DQPSK Meas Setup Table Example

Agilent Digital Modulation	
Ch Freq 1.00000 GHz	IF: Narrow Completed
Modulation Analysis	Pi/4 DQPSK Averages: 0
Modulation Format Pi/4 DQPSK	
Modulation Format	Pi/4 DQPSK Average On
Meas Filter	Root Nyquist Avg Number 10
Ref Filter	Nyquist Average Mode Exp
Alpha/BT	0.35 Trace Avg Type RMS
Symbol Rate	24.300 kHz FFT Window Type Flat Top
Meas Interval	157 symbols Trig Source Free Run
IF Band Width	97.20 kHz Carrier Lock Normal
IF Band Width Mode	Auto Sync RF Ampl
EQ Filter	Off Burst Search Th. -20.00 dB
EQ Filter Length	5 Search Length 49.000000 ms
EQ Convergence	1.000000 Sync Word Length 14 symbols
EQ Hold	Off Sync Offset 8 symbols
Sync Ptrn	A91DE4A

D8PSK Modulation Characteristics

Figure 4-24 D8PSK Error Vector Spectrum (Quad-View)

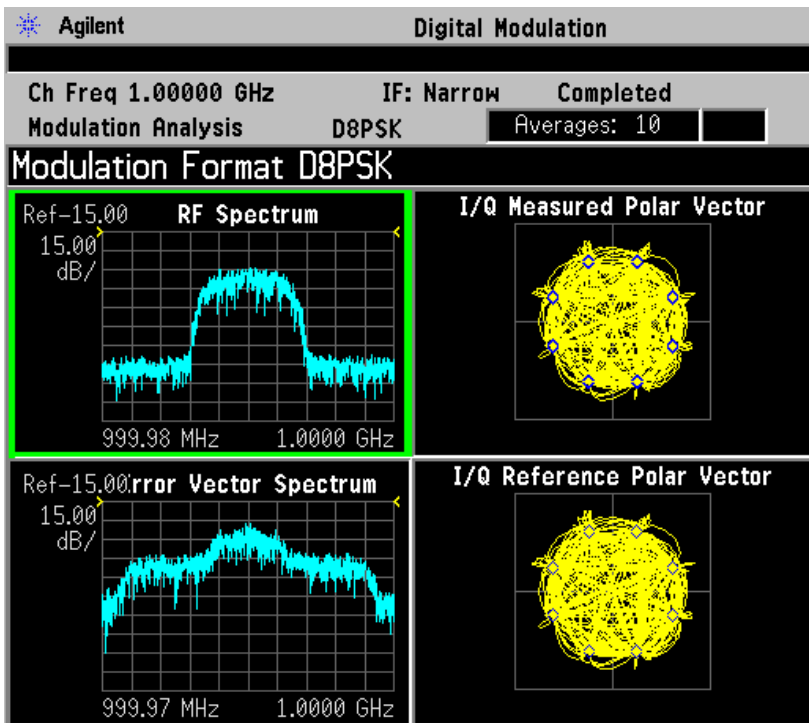

Figure 4-25 D8PSK Meas Setup Table Example

Agilent		Digital Modulation	
Ch Freq	1.00000 GHz	IF:	Narrow
Modulation Analysis	D8PSK	Completed	Averages: 10
Modulation Format D8PSK			
Modulation Format	D8PSK	Average	On
Meas Filter	No Filter	Avg Number	10
Ref Filter	Nyquist	Average Mode	Repeat
Alpha/BT	0.60	Trace Avg Type	RMS
Symbol Rate	10.500 kHz	FFT Window Type	Flat Top
Meas Interval	315 symbols	Trig Source	Free Run
IF Band Width	42.00 kHz	Carrier Lock	Normal
IF Band Width Mode	Auto	Sync	None
EQ Filter	Off	Burst Search Th.	-20.00 dB
EQ Filter Length	5	Search Length	120.000000 ms
EQ Convergence	1.000000	Sync Word Length	10 symbols
EQ Hold	Off	Sync Offset	0 symbols
Sync Ptrn	0000		

Offset QPSK Modulation Concepts

Offset QPSK (OQPSK) is used in the cellular CDMA (code division multiple access) system for the reverse (mobile to base) link.

In QPSK, the I and Q bit streams are switched at the same time. The symbol clocks, or the I and Q digital signal clocks, are synchronized. In offset QPSK (OQPSK), the I and Q bit streams are offset in their relative alignment by one half of a symbol period. This is shown in the diagram. Since the transitions of I and Q are offset, at any given time only one of the two bit streams can change values. This creates a dramatically different constellation, even though there are still just two I/Q values. This has power efficiency advantages. In OQPSK the signal trajectories are modified by the symbol clock offset so that the carrier amplitude does not go through or near zero (the center of the constellation). The spectral efficiency is the same with two I states and two Q states. The reduced amplitude variations (perhaps 3 dB for OQPSK, versus 30 to 40 dB for QPSK) allow a more power-efficient, less linear RF power amplifier to be used.

Figure 4-26 shows a comparison of the Eye diagrams of QPSK and Offset QPSK. To learn more, See “Eye diagrams” on page 295.

Figure 4-26

I/Q “Offset” Modulation

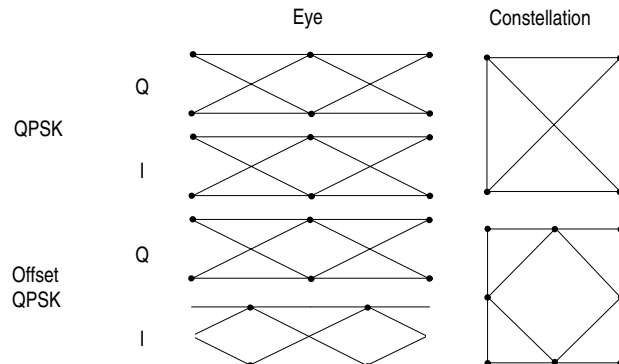

Offset QPSK Modulation Characteristics

Figure 4-27 Offset QPSK (OQPSK) Error Vector Spectrum (Quad-View)

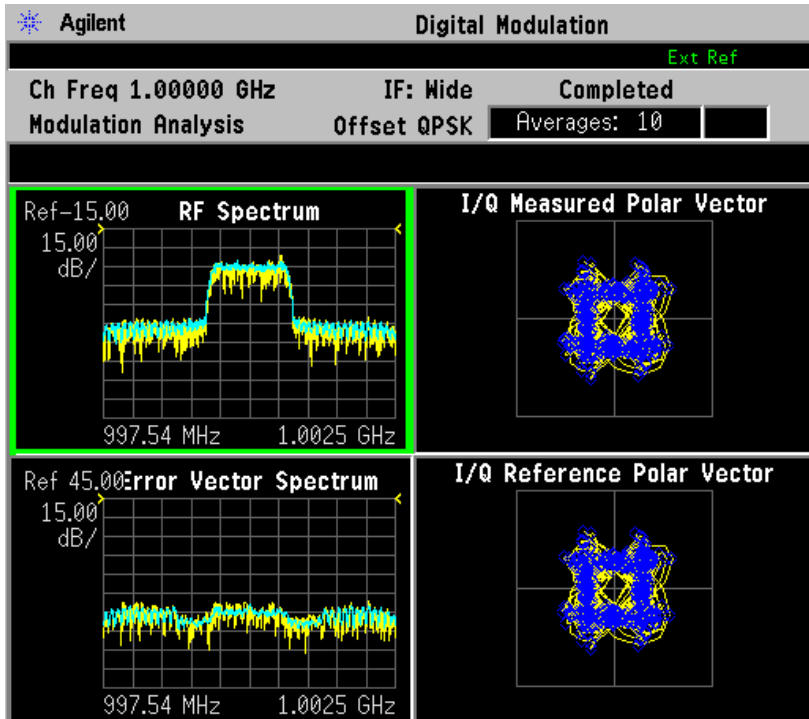

Figure 4-28 Offset QPSK (OQPSK) Meas Setup Table Example

Agilent Digital Modulation			
Ch Freq 1.00000 GHz		IF: Wide	Completed
Modulation Analysis		Offset QPSK	Averages: 10
Modulation Format Offset QPSK			
Modulation Format	Offset QPSK	Average	On
Meas Filter	No Filter	Avg Number	10
Ref Filter	CDMA	Average Mode	Repeat
Alpha/BT	0.22	Trace Avg Type	RMS
Symbol Rate	1.228800 MHz	FFT Window Type	Flat Top
Meas Interval	200 symbols	Trig Source	Free Run
IF Band Width	4.915 MHz	Carrier Lock	Normal
IF Band Width Mode	Auto	Sync	None
EQ Filter	Off	Burst Search Th.	-20.00 dB
EQ Filter Length	5	Search Length	10.000000 ms
EQ Convergence	1.000000	Sync Word Length	10 symbols
EQ Hold	Off	Sync Offset	0 symbols
Sync Ptrn	0000		

Frequency Shift Keying (FSK) Concepts

Figure 4-29

Frequency Shift Keying

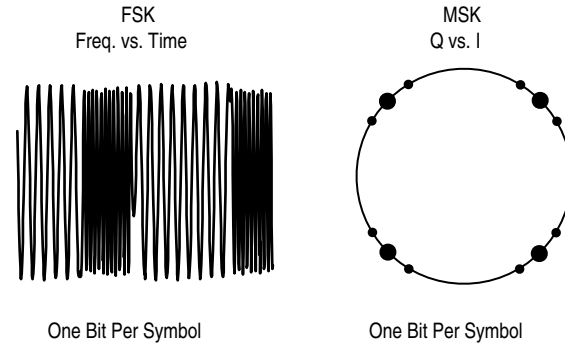

Frequency modulation and phase modulation are closely related. A static frequency shift of +1 Hz means that the phase is constantly advancing at the rate of 360 degrees per second (2π rad/sec), relative to the phase of the unshifted signal.

FSK (Frequency Shift Keying) is used in many applications including cordless and paging systems. Some of the cordless systems include DECT (Digital Enhanced Cordless Telephone) and CT2 (Cordless Telephone 2).

In FSK, the frequency of the carrier is changed as a function of the modulating signal (data) being transmitted. Amplitude remains unchanged. In binary FSK (BFSK or 2FSK), a “1” is represented by one frequency and a “0” is represented by another frequency.

FSK Modulation Characteristics

Figure 4-30 FSK Error Vector Spectrum (Quad-View) - 2 FSK Signal

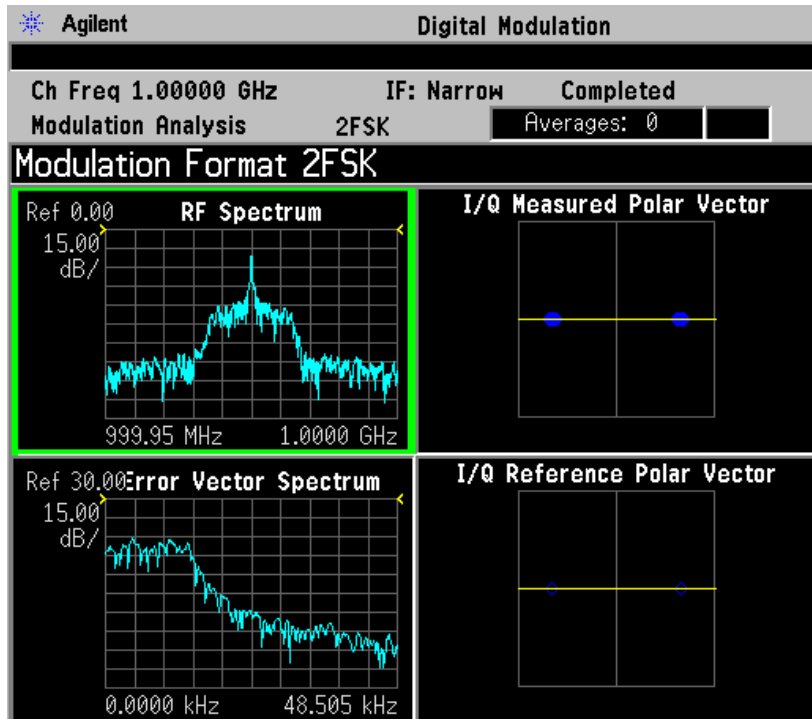

Figure 4-31 FSK Error Vector Spectrum (Quad-View)- 4FSK Signal

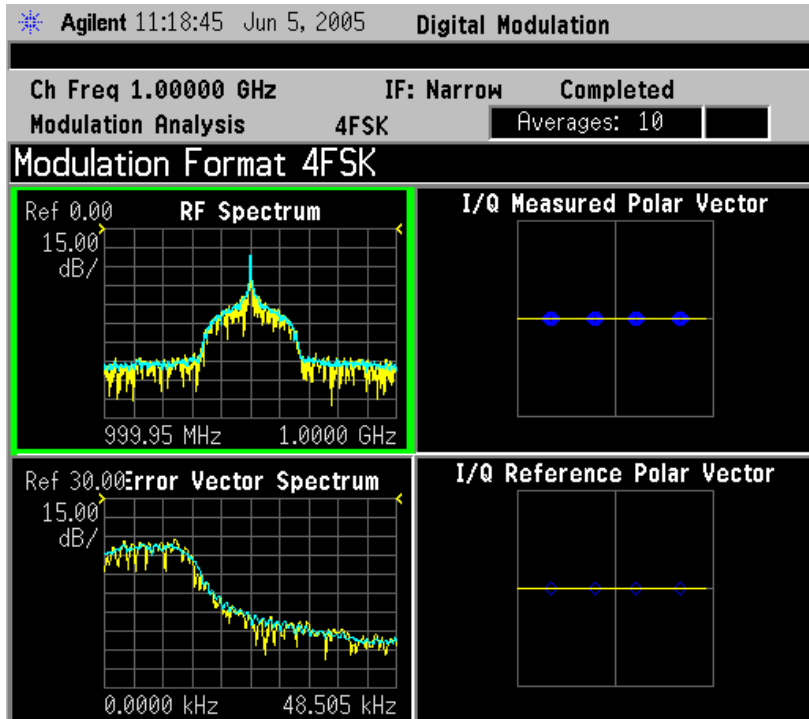

Figure 4-32 FSK I/Q Measured Polar Graph View- 8FSK Signal

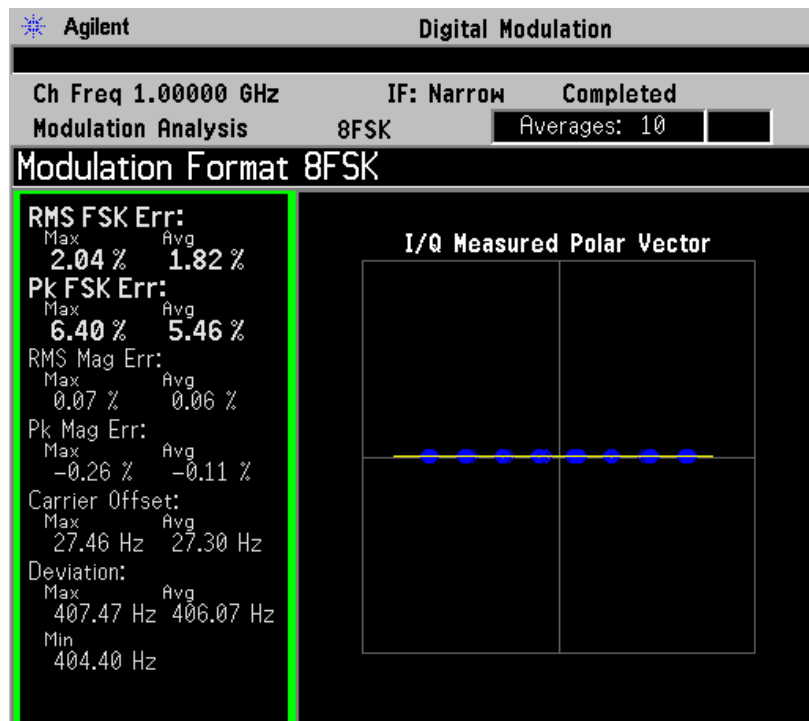

Figure 4-33 FSK Meas Setup Table Example

Agilent Digital Modulation	
Ch Freq 1.00000 GHz	IF: Narrow Completed
Modulation Analysis 8FSK	Averages: 10
Modulation Format 2FSK	
Modulation Format	2FSK Average On
Meas Filter	Root Nyquist Avg Number 10
Ref Filter	Nyquist Average Mode Repeat
Alpha/BT	0.35 Trace Avg Type RMS
Symbol Rate	24.300 kHz FFT Window Type Flat Top
Meas Interval	162 symbols Trig Source Free Run
IF Band Width	97.20 kHz Carrier Lock Normal
IF Band Width Mode	Auto Sync None
EQ Filter	Off Burst Search Th. -20.00 dB
EQ Filter Length	5 Search Length 49.000000 ms
EQ Convergence	1.000000 Sync Word Length 14 symbols
EQ Hold	Off Sync Offset 8 symbols
Sync Ptrn	A91DE4A

Concepts

Minimum Shift Keying (MSK) Concepts

Since a frequency shift produces an advancing or retarding phase, frequency shifts can be detected by sampling phase at each symbol period. Phase shifts of $(2N + 1) \pi/2$ radians are easily detected with an I/Q demodulator. At even numbered symbols, the polarity of the I channel conveys the transmitted data, while at odd numbered symbols the polarity of the Q channel conveys the data. This orthogonality between I and Q simplifies detection algorithms and hence reduces power consumption in a mobile receiver. The minimum frequency shift which yields orthogonality of I and Q is that which results in a phase shift of $\pm \pi/2$ radians per symbol (90 degrees per symbol). FSK with this deviation is called MSK (Minimum Shift Keying). The deviation must be accurate in order to generate repeatable 90 degree phase shifts. MSK is used in the GSM (Global System for Mobile Communications) cellular standard. A phase shift of +90 degrees represents a data bit equal to "1," while -90 degrees represents a "0." The peak-to-peak frequency shift of an MSK signal is equal to one-half of the bit rate.

FSK and MSK produce constant envelope carrier signals, meaning they have no amplitude variations. This is a desirable characteristic for improving the power efficiency of transmitters. Amplitude variations can exercise nonlinearities in an amplifier's amplitude-transfer function, generating spectral regrowth, a component of adjacent channel power. Therefore, more efficient amplifiers (which tend to be less linear) can be used with constant-envelope signals, reducing power consumption. MSK has a narrower spectrum than wider deviation forms of FSK. The width of the spectrum is also influenced by the waveforms causing the frequency shift. If those waveforms have fast transitions or a high slew rate, then the spectrum of the transmitter will be broad. In practice, the waveforms are filtered with a Gaussian filter, resulting in a narrow spectrum. In addition, the Gaussian filter has no time-domain overshoot, which would broaden the spectrum by increasing the peak deviation. MSK with a Gaussian filter is termed GMSK (Gaussian MSK).

Constant Envelope MSK Modulation

GSM uses a variation of constant amplitude modulation format called 0.3 GMSK (Gaussian Minimum Shift Keying).

In constant-envelope modulation the amplitude of the carrier is constant, regardless of the variation in the modulating signal. It is a power-efficient scheme that allows efficient class-C amplifiers to be used without introducing degradation in the spectral occupancy of the transmitted signal. However, constant-envelope modulation techniques occupy a larger bandwidth than schemes which are linear. In linear schemes, the amplitude of the transmitted signal varies with the modulating digital signal as in BPSK or QPSK. In systems where

bandwidth efficiency is more important than power efficiency, constant envelope modulation is not as well suited.

MSK is a special type of FSK where the peak-to-peak frequency deviation is equal to half the bit rate.

GMSK is a derivative of MSK where the bandwidth required is further reduced by passing the modulating waveform through a Gaussian filter. The Gaussian filter minimizes the instantaneous frequency variations over time. GMSK is a spectrally efficient modulation scheme and is particularly useful in mobile radio systems. It has a constant envelope, spectral efficiency, good BER performance, and is self-synchronizing.

Figure 4-34

Constant Envelope MSK Modulation

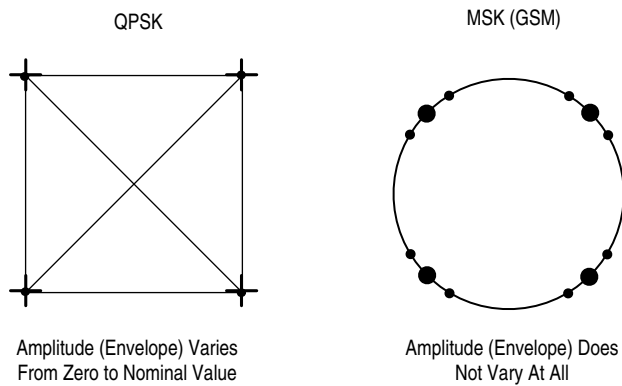

Fig. 17

MSK Modulation Characteristics

Figure 4-35

MSK Error Vector Spectrum (Quad-View)

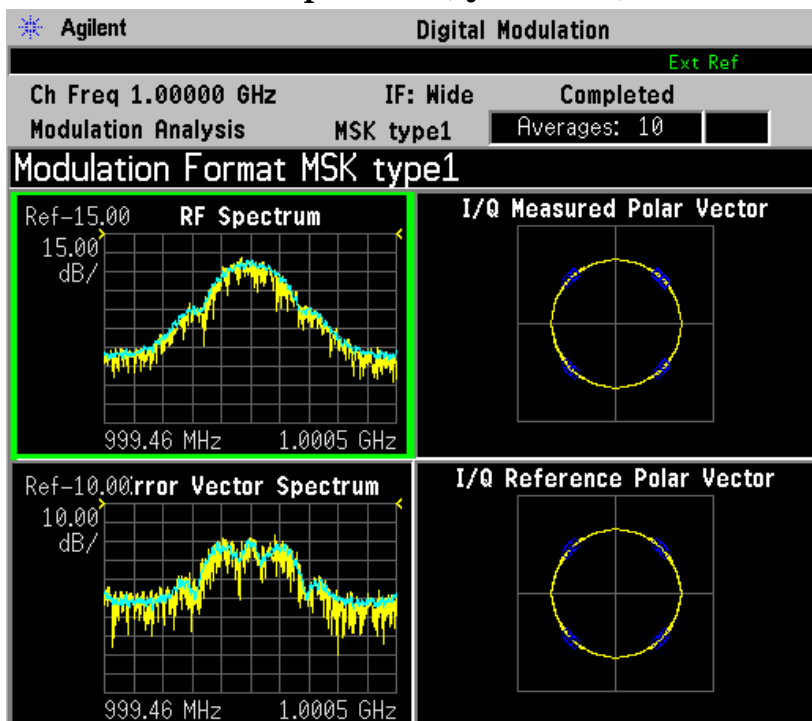

Figure 4-36

MSK Meas Setup Table Example

Agilent		Digital Modulation	
Ch Freq 1.00000 GHz		IF: Wide	Completed
Modulation Analysis		MSK type1	Averages: 10
Modulation Format MSK type1			
Modulation Format	MSK type1	Average	On
Meas Filter	No Filter	Avg Number	10
Ref Filter	Gaussian	Average Mode	Repeat
Alpha/BT	0.30	Trace Avg Type	RMS
Symbol Rate	270.833 kHz	FFT Window Type	Flat Top
Meas Interval	148 symbols	Trig Source	Free Run
IF Band Width	1.083 MHz	Carrier Lock	Normal
IF Band Width Mode	Auto	Sync	None
EQ Filter	Off	Burst Search Th.	-20.00 dB
EQ Filter Length	5	Search Length	6.000000 ms
EQ Convergence	1.000000	Sync Word Length	26 symbols
EQ Hold	Off	Sync Offset	61 symbols
Sync Ptrn	0970897		

Quadrature Amplitude Modulation (QAM) Concepts

Quadrature amplitude modulation (QAM) is used in applications including microwave digital radio, DVB-C (Digital Video Broadcasting—Cable), and modems.

16 QAM

In 16-state quadrature amplitude modulation (16QAM), there are four I values and four Q values. This results in a total of 16 possible states for the signal. It can transition from any state to any other state at every symbol time. Since $16 = 2^4$ four bits per symbol can be sent. This consists of two bits for I, and two bits for Q. The symbol rate is one fourth of the bit rate. So this modulation format produces a more spectrally efficient transmission. It is more efficient than BPSK, QPSK, or 8PSK.

Note that to a point QPSK is the same as 4QAM.

32 QAM

Another variation is 32QAM. In this case there are six I values and six Q values resulting in a total of 36 possible states ($6 \times 6 = 36$). This number is too many states for a power of two (the closest power of two is 32). So the four corner symbol states, which take the most power to transmit, are omitted. This reduces the amount of peak power the transmitter has to generate. Since $2^5 = 32$, there are five bits per symbol and the symbol rate is one fifth of the bit rate.

The current practical limits are approximately 256QAM, though work is underway to extend the limits to 512 or 1024 QAM. High state QAM formats are better suited to cable delivery where the noise is lessened.

A 256QAM system uses 16 I-values and 16 Q-values, giving 256 possible states. Since $2^8 = 256$, each symbol can represent eight bits. A 256QAM signal that can send eight bits per symbol is very spectrally efficient. However, for a given maximum power, the symbols are closer together than lower-valued QAM's and are thus more subject to errors due to noise and distortion. Such a signal may have to be transmitted with extra power (to effectively spread the symbols out more) and this reduces power efficiency as compared to simpler schemes.

Figure 4-37 Quadrature Amplitude Modulation

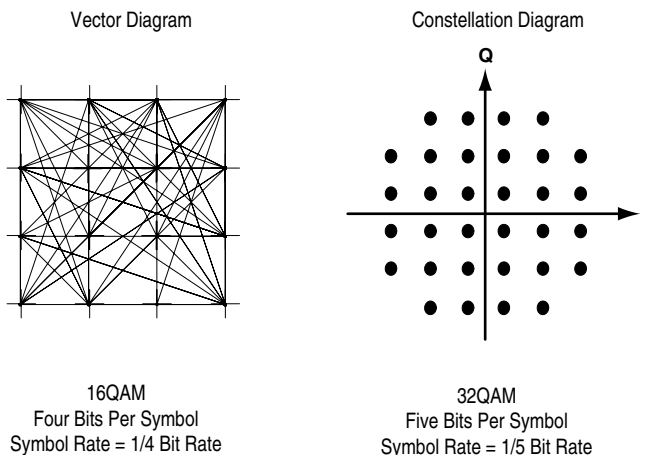

However, bandwidth efficiency is better for higher QAM's. For example, BPSK uses 80 Ksymbols-per-second sending 1 bit per symbol. A system using 256QAM sends eight bits per symbol so the symbol rate would be 10 Ksymbols per second. A 256QAM system enables the same amount of information to be sent as BPSK using only one eighth of the bandwidth. It is eight times more bandwidth efficient. However, there is a trade-off. The radio becomes more complex and is more susceptible to errors caused by noise and distortion. Error rates of higher-order QAM systems such as this degrade more rapidly than QPSK as noise or interference is introduced. A measure of this degradation would be a higher bit error rate (BER).

In any digital modulation system, if the input signal is distorted or severely attenuated the receiver will eventually lose symbol lock completely. If the receiver can no longer recover the symbol clock, it cannot demodulate the signal or recover any information. With less degradation, the symbol clock can be recovered, but it is noisy, and the symbol locations themselves are noisy. In some cases, a symbol will fall far enough away from its intended position that it will cross over to an adjacent position. The I and Q level detectors used in the demodulator would misinterpret such a symbol as being in the wrong location, causing bit errors. QPSK is not as efficient, but the states are much farther apart for a given power and the system can tolerate a lot more noise before suffering symbol errors. QPSK has no intermediate states between the four corner-symbol locations, so there is less opportunity for the demodulator to misinterpret symbols. QPSK requires less transmitter power than QAM to achieve the same bit error rate.

QAM Modulation Characteristics

Figure 4-38

16QAM Error Vector Spectrum (Quad-View)

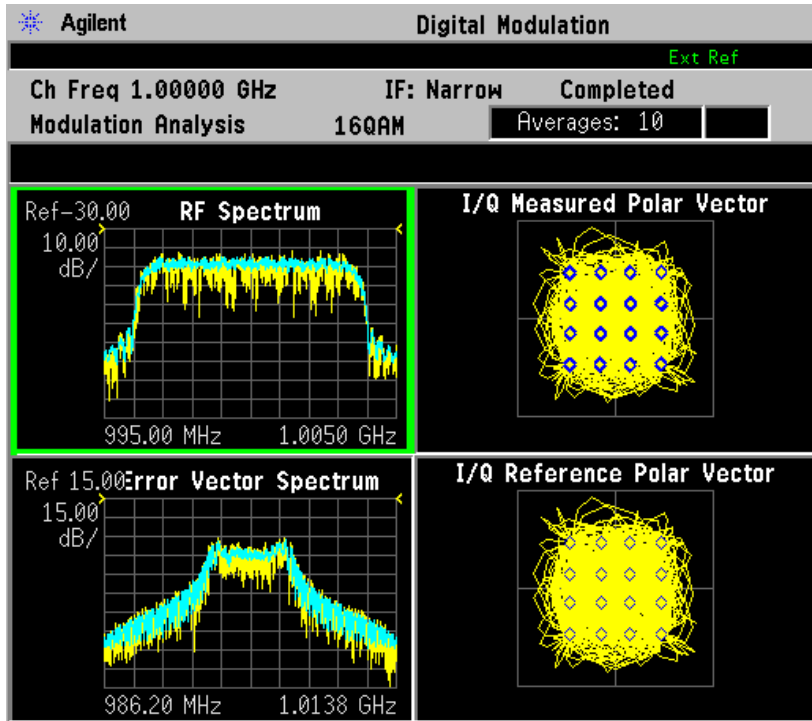

Concepts

Figure 4-39

16 QAM Meas Setup Table Example

Agilent Digital Modulation			
Ch Freq 1.00000 GHz		IF: Narrow	Completed
Modulation Analysis		16QAM	Averages: 10
Modulation Format 16QAM			
Modulation Format	16QAM	Average	On
Meas Filter	Root Nyquist	Avg Number	10
Ref Filter	Nyquist	Average Mode	Repeat
Alpha/BT	0.15	Trace Avg Type	RMS
Symbol Rate	6.900000 MHz	FFT Window Type	Flat Top
Meas Interval	800 symbols	Trig Source	Free Run
IF Band Width	10.00 MHz	Carrier Lock	Normal
IF Band Width Mode	Auto	Sync	None
EQ Filter	Off	Burst Search Th.	-20.00 dB
EQ Filter Length	5	Search Length	10.000000 ms
EQ Convergence	1.000000	Sync Word Length	10 symbols
EQ Hold	Off	Sync Offset	0 symbols
Sync Ptrn	0000		

Modulation Bit State Diagrams

This section shows bit state diagrams for various digital modulation formats that may be demodulated by the Modulation Analysis measurement, including FSK, PSK, QAM, and DVB QAM. Constellation diagrams are used to illustrate most PSK and complex modulation formats, while BPSK and FSK are mapped to a single axis.

Bit State Diagrams by Modulation Family

The bit state diagrams are grouped by modulation family on the following pages:

[“FSK Bit state Diagrams” on page 224](#)

[“PSK Bit State Diagrams” on page 226](#)

[“QAM Bit State Diagrams” on page 230](#)

[“DVB QAM Bit State Diagrams” on page 234](#)

FSK Bit state Diagrams

FSK bit state diagrams are represented as states on a single axis.

Figure 4-40

2FSK Bit State Diagram



Figure 4-41 4FSK Bit State Diagram



Figure 4-42 8FSK Bit State Diagram



PSK Bit State Diagrams

PSK bit state diagrams are mostly represented below in constellation diagrams, except for BPSK, which is shown as states on a single axis.

Figure 4-43 BPSK Bit State Diagram

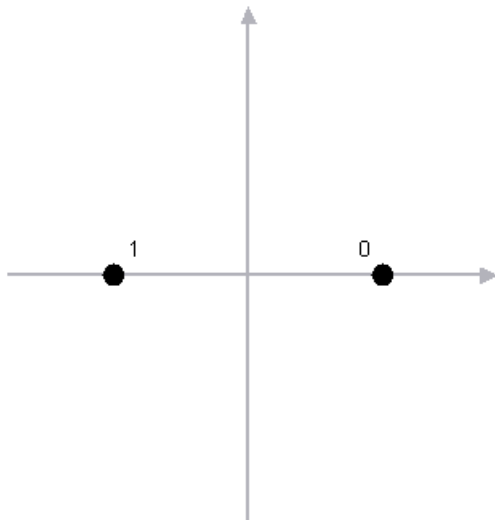
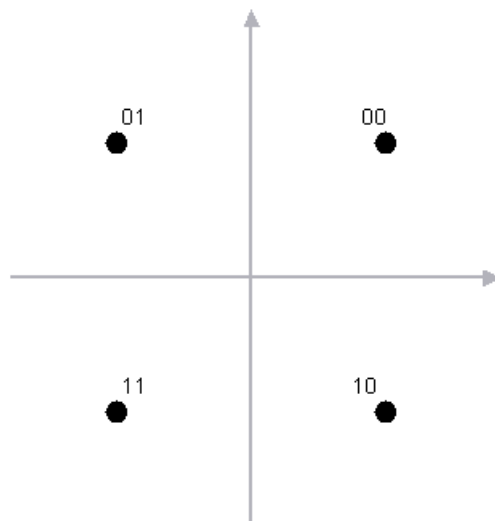

Figure 4-44 QPSK Bit State Diagram



Concepts

Figure 4-45 OQPSK (Offset QPSK) Bit State Diagram

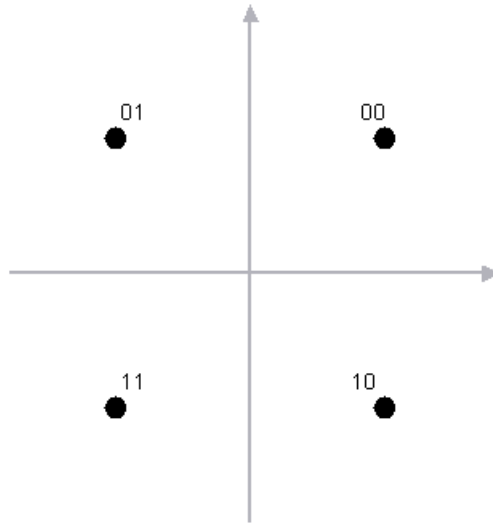
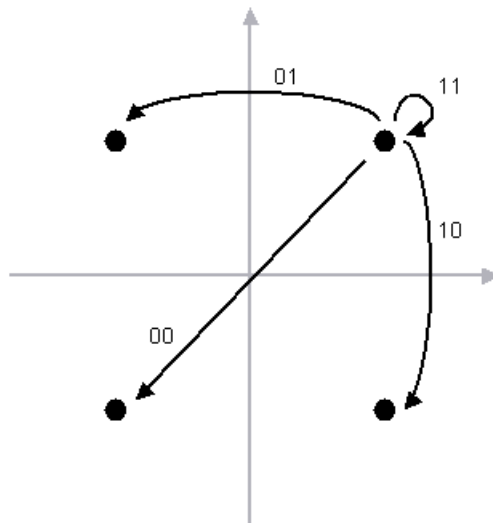

Figure 4-46 DQPSK (Differential QPSK) Bit State Diagram



Concepts

Figure 4-47 8PSK Bit State Diagram

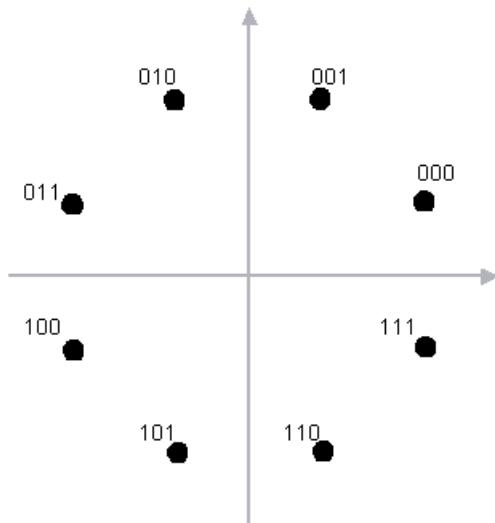
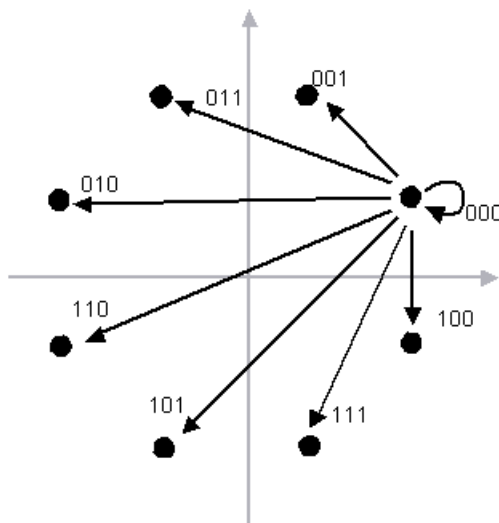
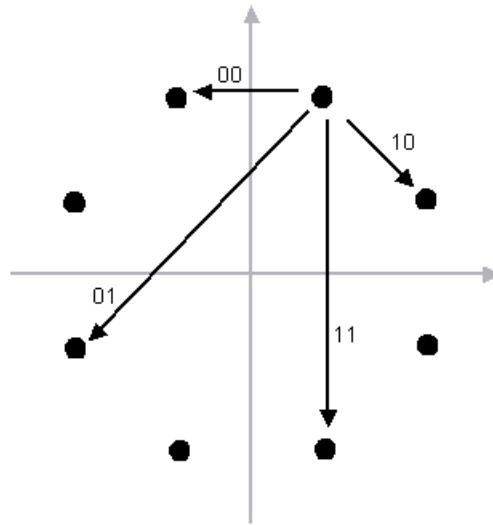

Figure 4-48 D8PSK (Differential 8PSK) Bit State Diagram



Concepts

Figure 4-49 $\pi/4$ DQPSK Bit State Diagram



QAM Bit State Diagrams

QAM bit states are represented below in constellation diagrams.

Figure 4-50 16 QAM Bit State Diagram

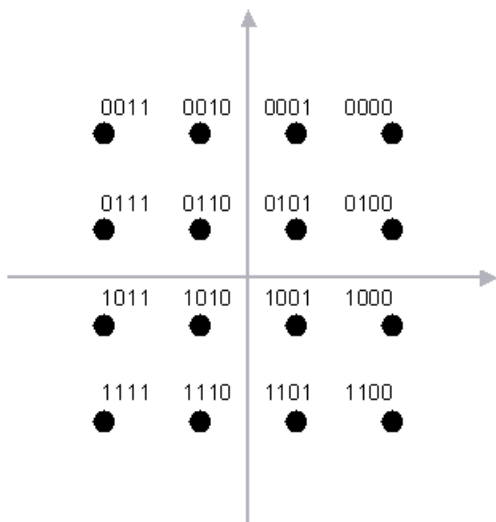
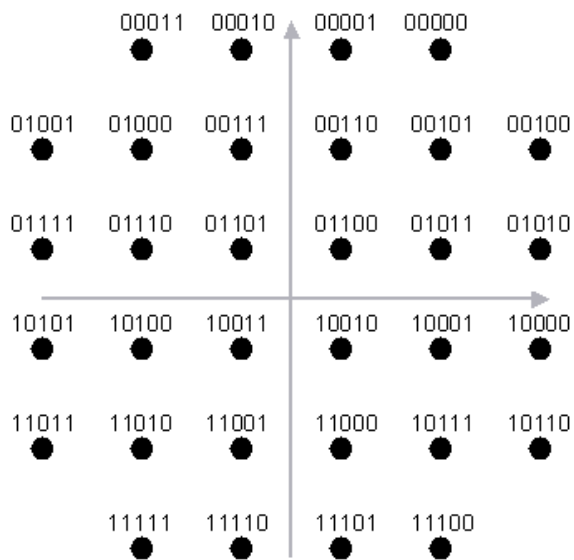
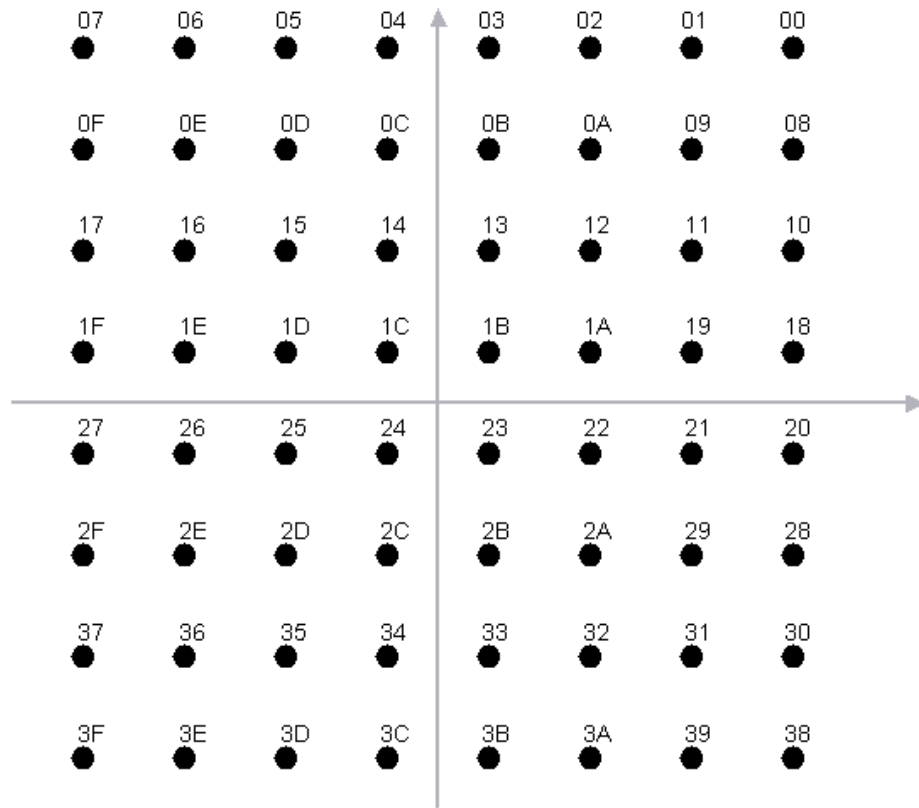

Figure 4-51 32 QAM Bit State Diagram



Concepts

Figure 4-52 64 QAM Bit State Diagram



Concepts

Figure 4-53 128 QAM Bit State Diagram

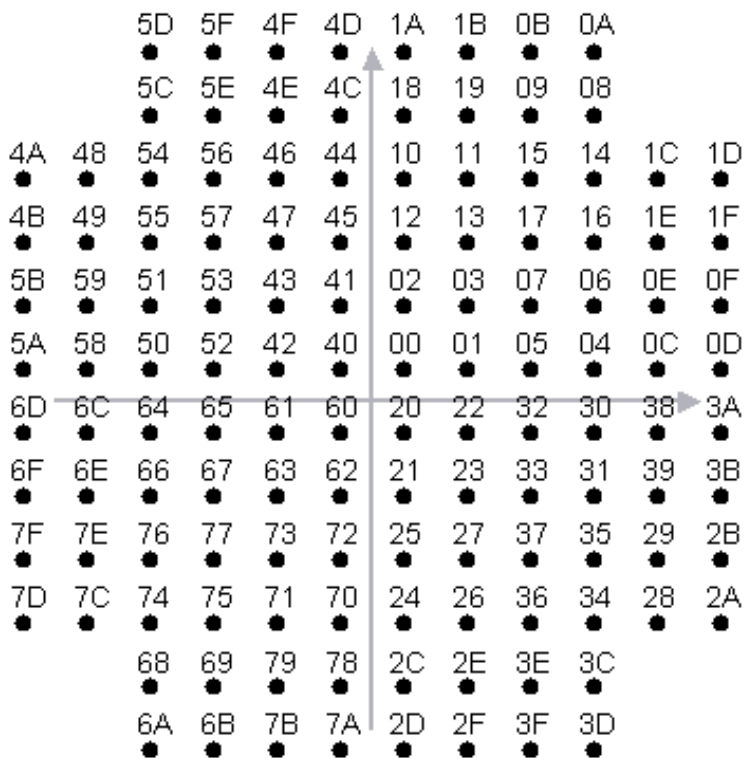
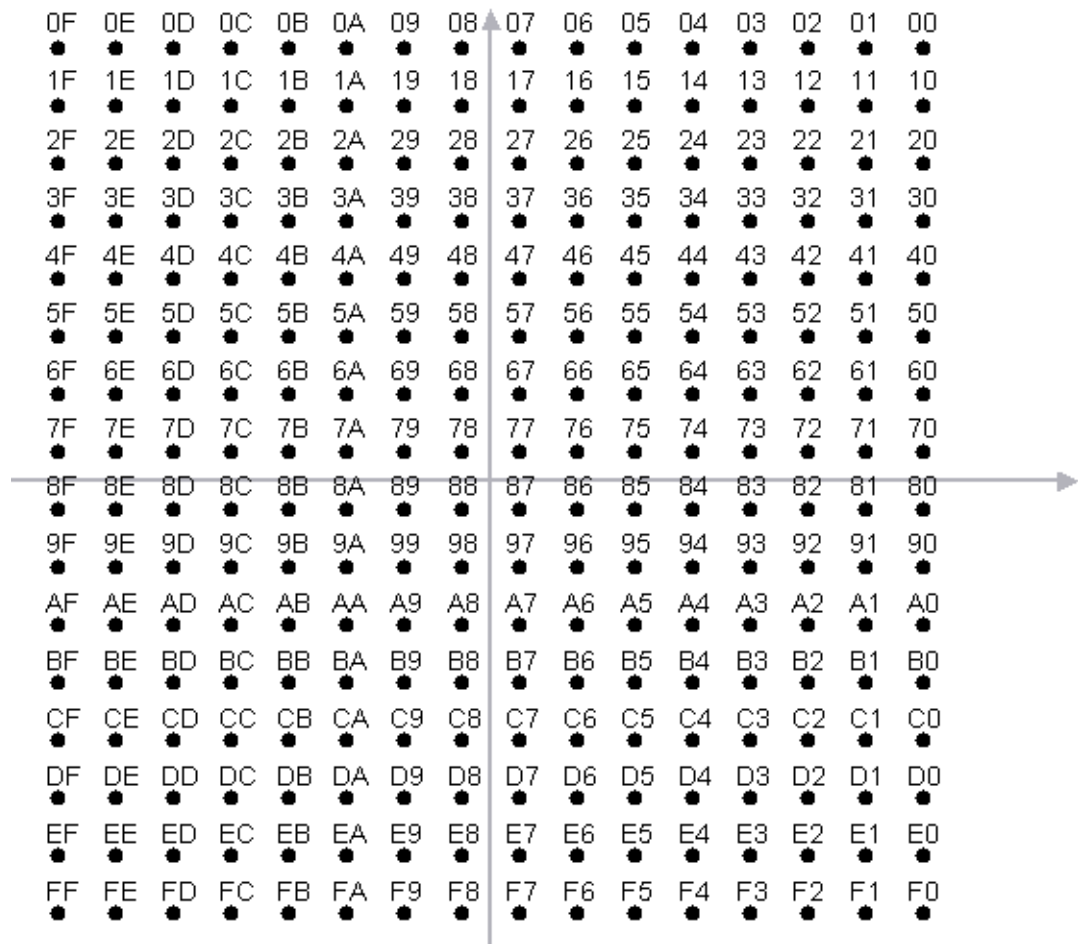

Figure 4-54 256 QAM Bit State Diagram



DVB QAM Bit State Diagrams

DVB QAM bit states are represented below in constellation diagrams.

As shown in [Figure 4-55](#), [Figure 4-56](#), and [Figure 4-57](#), the constellation points in Quadrant 1 are converted to Quadrants 2, 3, and 4 by changing the two MSBs (i.e. I_k and Q_k) and by rotating the q LSBs according to the rule given in [Table 4-3](#), below.

Table 4-3 DVB 16QAM, 32 QAM, 64QAM Rotation Rules

Quadrant	MSBs	LSBs Rotation
1	00	
2	10	$+\pi/2$
3	11	$+\pi$
4	01	$+3\pi/2$

Figure 4-55 DVB 16QAM Bit State Diagram

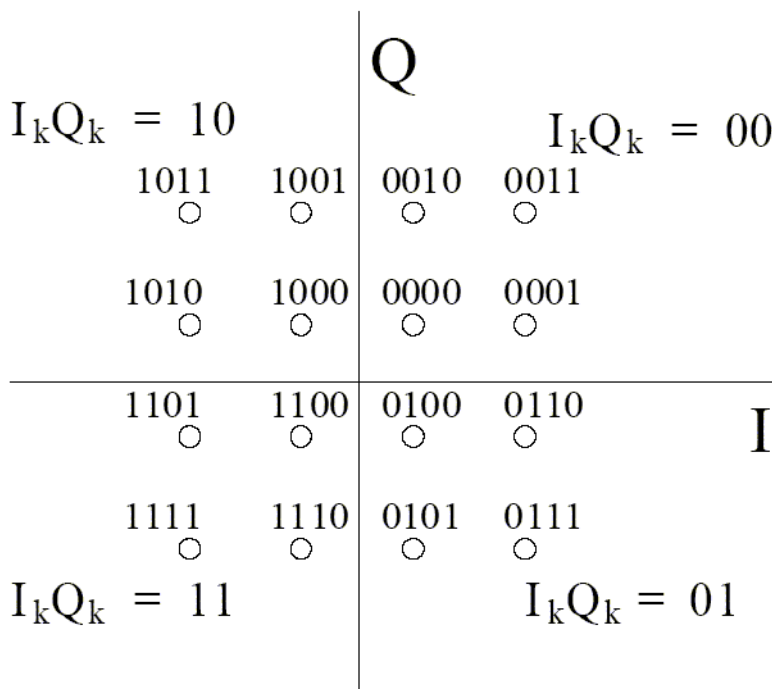

Figure 4-56 DVB 32QAM Bit State Diagram

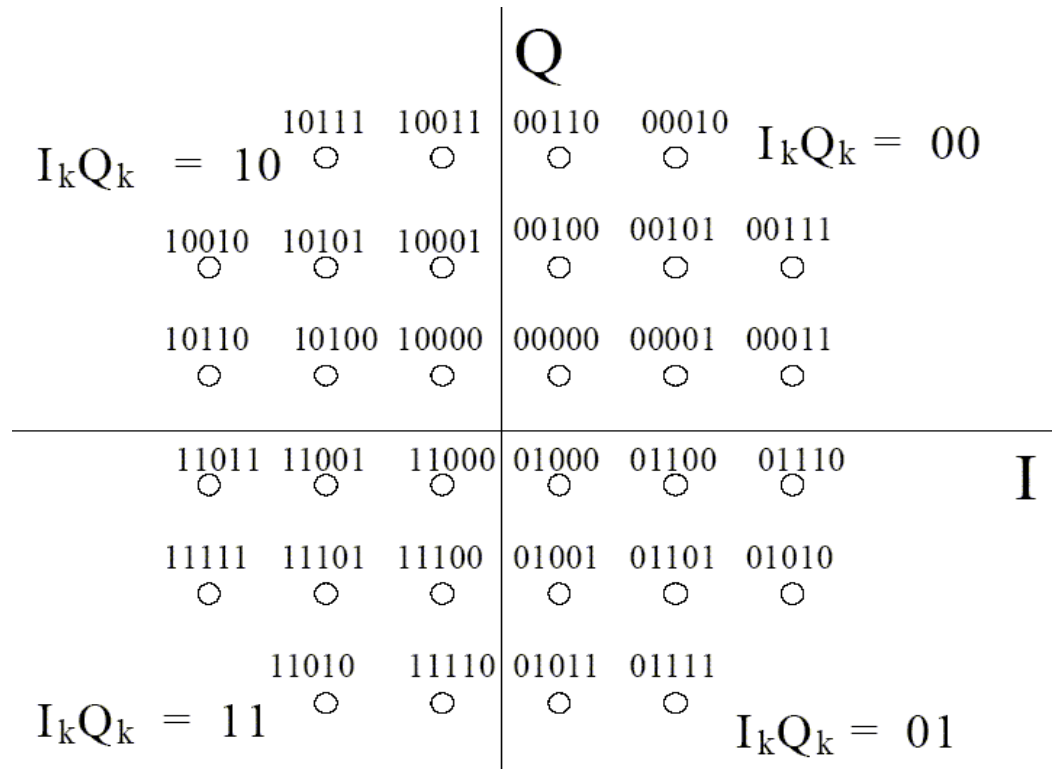
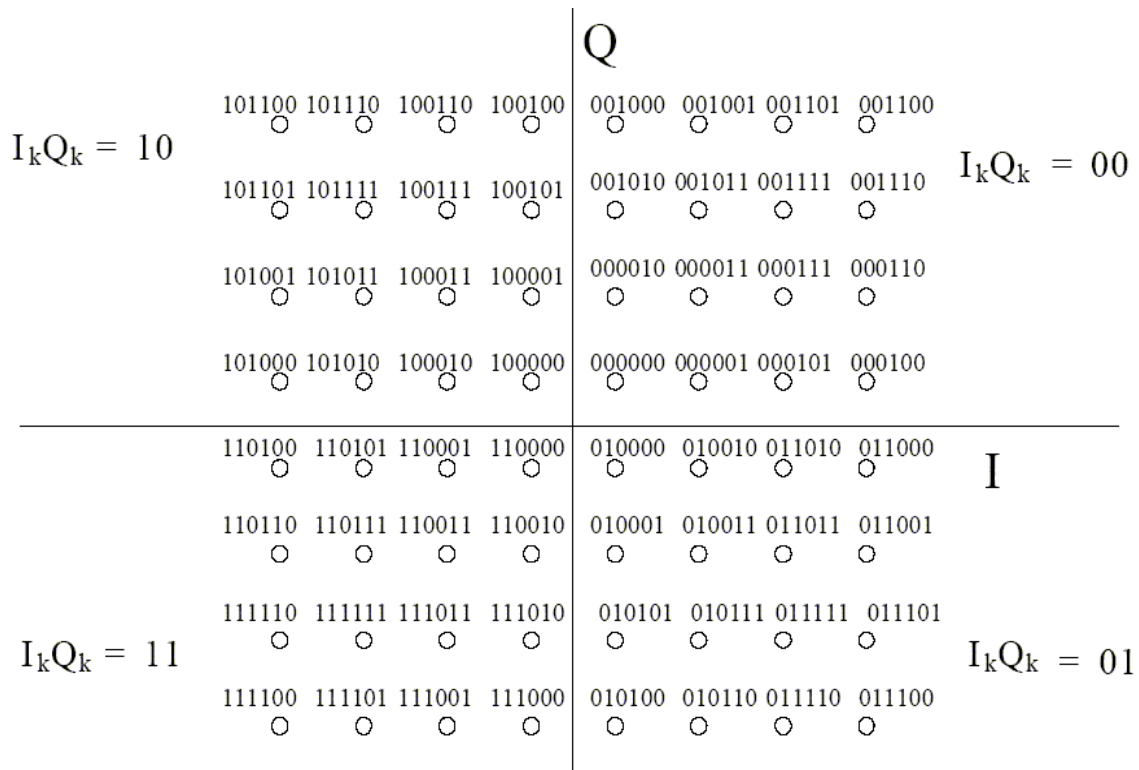
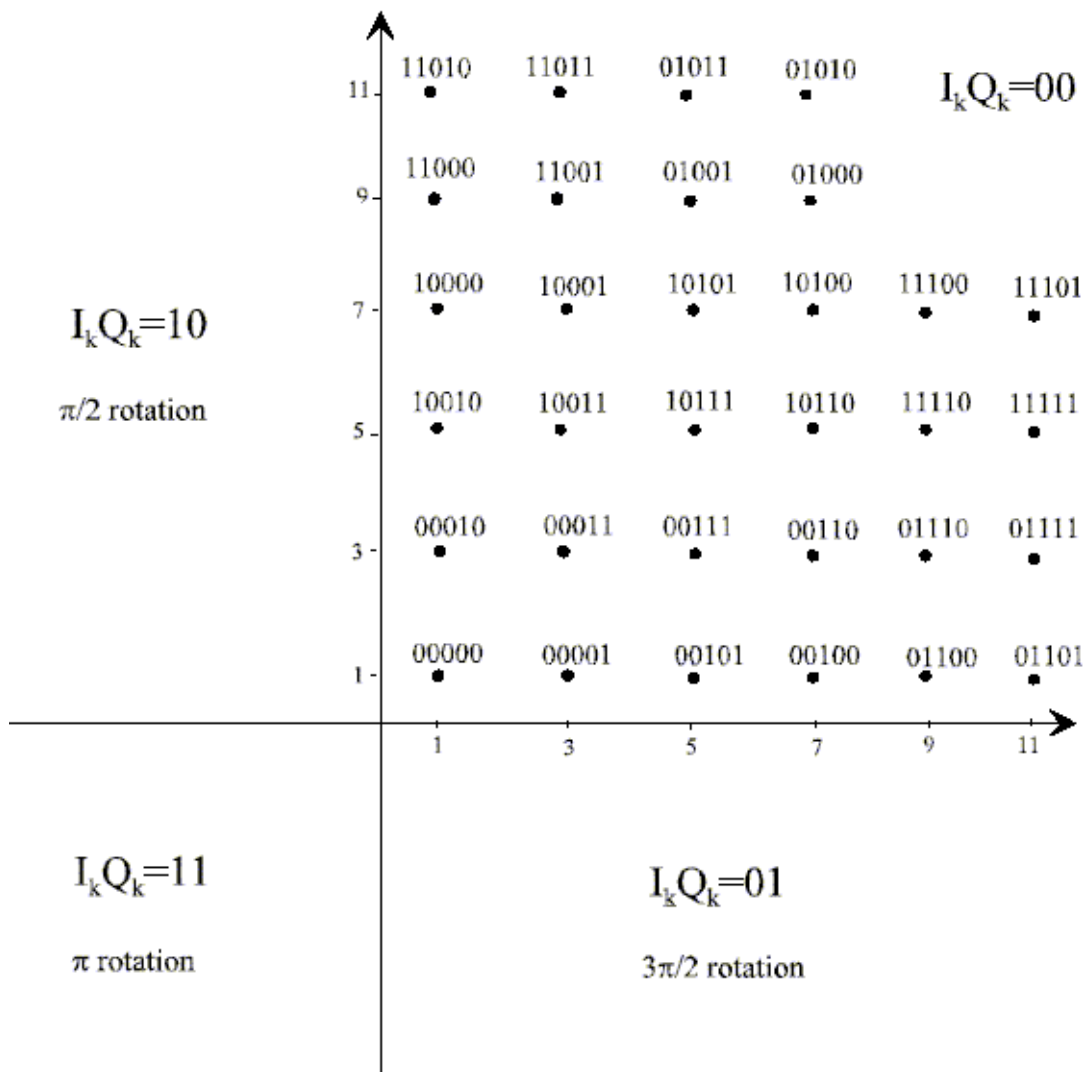

Figure 4-57 DVB 64QAM Bit State Diagram



Concepts

Figure 4-58 DVB 128QAM Bit State Diagram



Concepts

Figure 4-59 DVB 256QAM Bit State Diagram

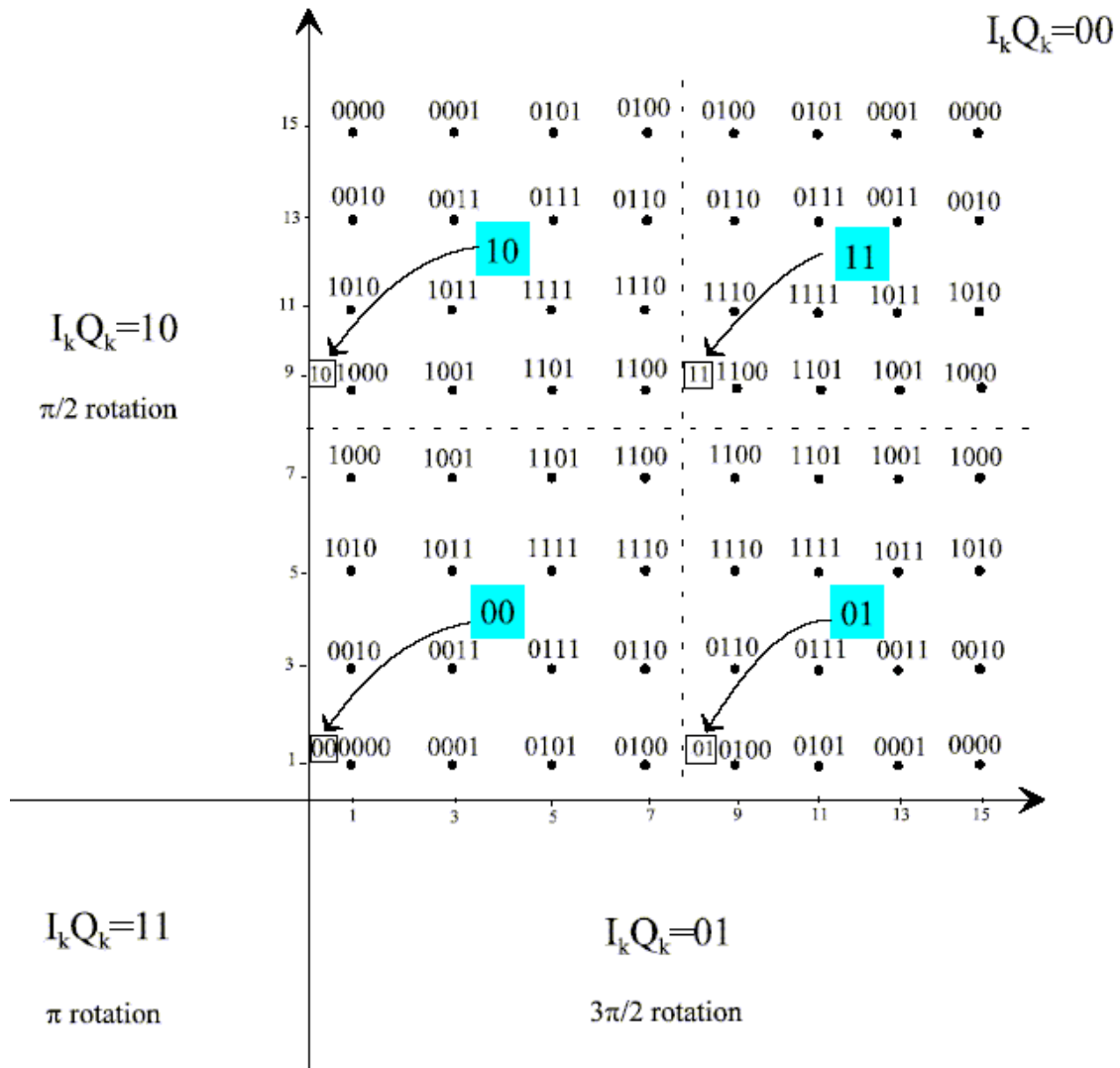

Concepts

Communication System Formats

PSA option 241 Communications Format Standards

- IS-95 [page 239](#)
- W-CDMA [page 242](#)
- cdma2000 [page 247](#)
- NADC [page 251](#)
- PDC [page 255](#)
- PHS [page 257](#)
- TETRA [page 259](#)
- Bluetooth [page 262](#)
- GSM [page 266](#)
- EDGE [page 266](#)
- APCO25 phase1 [page 266](#)
- VDL Mode 3 [page 276](#)
- ZigBee 2450MHz [page 277](#)

NOTE

PSA option 241 can analyze digital modulation for a single code channel only. If multiple code channels are transmitted, synchronization will fail, and incorrect EVM results will be obtained. For modulation quality measurements of multiple code channels, Modulation Accuracy and Code Domain measurements must be performed by a full-featured standard-based personality, like PSA Option BAF for W-CDMA.

What is the cdmaOne (IS-95) Communication System?

Code Division Multiple Access (CDMA) is a direct sequence spread-spectrum digital communications technique that was originally designed for military applications. The main advantages of CDMA over other types of communications schemes are:

- greater capacity than with other techniques
- immunity to signal loss and degradation in the presence of high broadband interference
- immunity to signal loss and degradation due to multipath, scatter, and fading
- power consumption of mobile stations is strictly minimized (by base station control)
- supports full 9600 baud capability for voice and data communications
- provides increased security

CDMA uses correlative codes to distinguish one user from another. Frequency division is still used, as is done with Frequency Division Multiple Access (FDMA) and Time Division Multiple Access (TDMA), but in a much larger bandwidth (1.25 MHz). CDMA uses a direct sequence spread spectrum technique that realizes increased capacity from 1:1 frequency reuse and sectorized cells. The capacity limit is soft. That is, capacity can be increased with some degradation of the error rate or voice quality.

In cdmaOne, a single user's channel consists of a specific frequency combined with a unique code. Correlative codes allow each user to operate in the presence of substantial interference. The interference is the sum of all other users on the same cdmaOne frequency, both from within and without the home cell, and from delayed versions of these signals. It also includes the usual thermal noise and atmospheric disturbances. Delayed signals caused by multipath are separately received and combined in cdmaOne. One of the major differences in access, compared to a non-cdma system, is that any cdmaOne frequency can be used in all sectors of all cells. This is possible because cdmaOne is designed to decode the proper signal in the presence of high interference.

The cdmaOne communication system is defined in the following Electronics Industry Association (EIA) and Telecommunications Industry Association (TIA) documents:

TIA/EIA/ IS-95-A	Mobile Station - Base Station Compatibility Standard for Dual-Mode Wideband Spread Spectrum Cellular System
TIA/EIA-97-B	Recommended Minimum Performance Standards for Base Stations Supporting Dual-Mode Wideband Spread Spectrum Cellular Mobile Stations

TIA/EIA-98-B Recommended Minimum Performance Standards for dual-Mode Wideband Spread Spectrum Cellular Mobile Stations

And the following American National Standards Institute (ANSI) documents:

J-STD-008 Personal Station-Base Station Compatibility Requirements for 1.8 to 2.0 GHz Code Division Multiple Access (CDMA) Personal Communications Systems

J-STD-018 Recommended Minimum Performance Requirements for 1.8 to 2.0 GHz Code Division Multiple Access (CDMA) Personal Stations

J-STD-019 Recommended Minimum Performance Requirements for Base Stations Supporting 1.8 to 2.0 GHz Code Division Multiple Access (CDMA) Personal Stations

cdmaOne Communication System

Figure 4-60

cdma One Error Vector Spectrum (Quad-View)

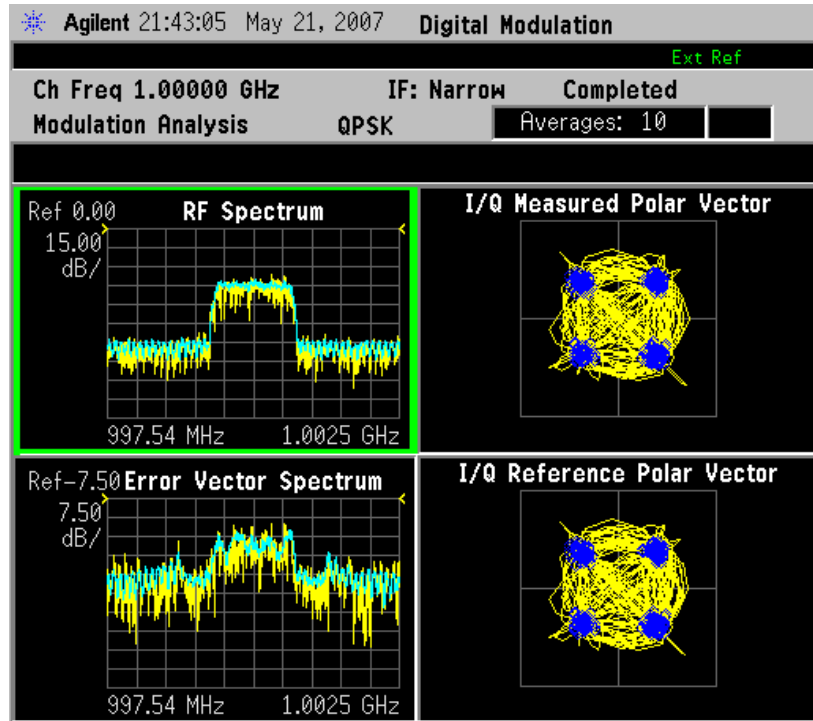

Concepts

Figure 4-61

cdmaOne Meas Setup Table Example

Agilent Digital Modulation			
Ch Freq 1.00000 GHz		IF: Narrow Completed	
Modulation Analysis		QPSK Averages: 0	
Modulation Format QPSK			
Modulation Format	QPSK	Average	0n
Meas Filter	CDMA	Avg Number	10
Ref Filter	CDMA	Average Mode	Repeat
Alpha/BT	0.22	Trace Avg Type	RMS
Symbol Rate	1.228800 MHz	FFT Window Type	Flat Top
Meas Interval	200 symbols	Trig Source	Free Run
IF Band Width	4.915 MHz	Carrier Lock	Normal
IF Band Width Mode	Auto	Sync	None
EQ Filter	Off	Burst Search Th.	-20.00 dB
EQ Filter Length	5	Search Length	10.000000 ms
EQ Convergence	1.000000	Sync Word Length	10 symbols
EQ Hold	Off	Sync Offset	0 symbols
Sync Ptrn	0000		

What is the W-CDMA Communications System?

Wideband code division multiple access (W-CDMA) is a popular air interface technology for third generation RF cellular communications systems. In W-CDMA (3GPP), the cells operate asynchronously, which makes the mobile synchronization more complex, but offers the advantage of flexibility in placement of the base stations. Both reverse and forward transmitter power controls are implemented with 0.625 ms intervals. W-CDMA is a direct sequence spread-spectrum digital communications technique that supports wider RF bandwidths, typically from 5 to 20 MHz. The main advantages of W-CDMA over other types of communication schemes are:

- greater capacity
- immunity to signal loss and degradation due to high-level broadband interference, multipath, scattering, and fading
- power consumption of mobile stations or user equipment (UE) is strictly minimized by both base station and mobile controls
- supports variable data rates up to 144 kbits/second for mobile (vehicular) data rate, up to 384 kbits/second for portable (pedestrian) data rate, and up to 2 Mbits/second for fixed installations
- provides increased security

W-CDMA uses correlative codes to distinguish one user from another. Frequency division is still used, as is done with Frequency Division Multiple Access (FDMA) and Time Division Multiple Access (TDMA), but in a much larger bandwidth such as 5 MHz or greater. An initial baseband data rate is spread to a transmitted bit rate of 3.840 Mcps, which is also called chip rate or spread data rate. W-CDMA realizes increased capacity from 1:1 frequency reuse and sectored cells. The capacity limit is soft. That is, capacity can be increased with some degradation of the error rate or voice quality.

W-CDMA Code Division Multiple Access

As its name implies, W-CDMA is a code division multiple access (CDMA) system. As opposed to time division multiple access (TDMA), in CDMA, all users transmit at the same time. Frequency divisions are still used, but at a much larger bandwidth. In addition, multiple users share the same frequency carrier. Each user's signal uses a unique code that appears to be noise to all except the correct receiver. Therefore, the term channel describes a combination of carrier frequency and code. Correlation techniques allow a receiver to decode one signal among many that are transmitted on the same carrier at the same time. [Figure 4-62 on page 243](#) shows a simplified version of the transmission and reception processes for a W-CDMA system. One difference between W-CDMA and earlier existing 2G CDMA systems (like IS-95) is that W-CDMA uses a wider bandwidth (3.84 MHz, as opposed to 1.23 MHz for IS-95).

Figure 4-62 W-CDMA Transmission and Reception Processes

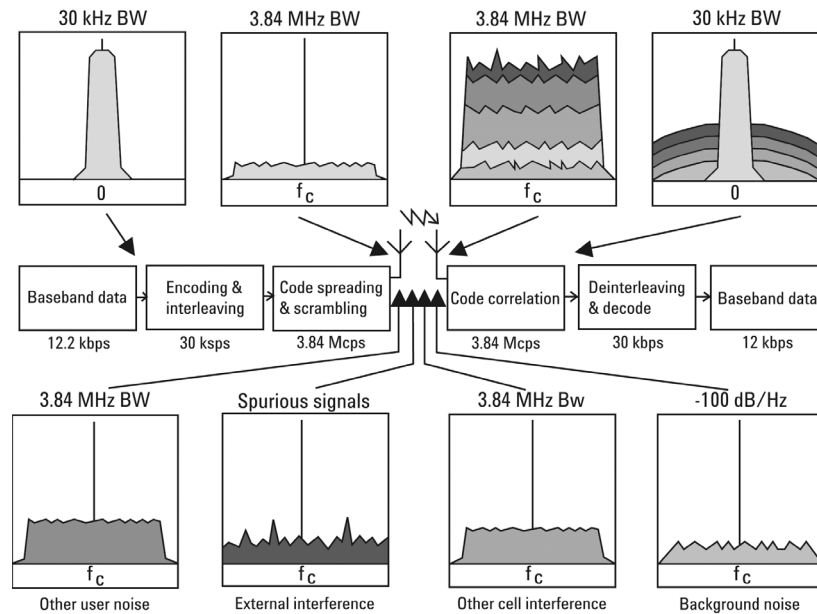

In W-CDMA, a single user's channel consists of a specific frequency combined with a unique code. Correlative codes allow each user to operate in the presence of substantial interference. The interference is the sum of all other users on the same W-CDMA frequency, both from within and outside of the home cell, and from delayed versions of these signals. It also includes the usual thermal noise and atmospheric disturbances. Delayed signals caused by multipath are separately received and combined in W-CDMA. Unlike access in non-CDMA systems, any W-CDMA frequency can be used in all sectors of all cells.

The W-CDMA system starts with a narrowband signal at a data rate of 12.2 kbps. In reality, this data rate is variable, up to 2 Mbps. After coding and interleaving, the resulting symbol rate in this example is 30 kpsps. This is spread with the use of specialized codes to a bandwidth of 3.84 MHz. The final spread bits are called chips, and the final spread rate is defined in terms of chips per second (3.84 Mcps for W-CDMA). The ratio of the spread data rate (3.84 Mcps) to the encoded data rate (30 kpsps in this case) is called the spreading gain. The ratio of the spread data rate to the initial data rate (12.2 kbps in this case) is called the processing gain (overall coding gain). In CDMA systems the spreading gain is a big contributor to the processing gain. The processing gain allows the receiver's correlator to extract the desired signal from the noise. When transmitted, a CDMA signal experiences high levels of interference, dominated by the signals of other CDMA users. This takes two forms, interference from other users in the same cell and interference from adjacent cells. The total interference also includes background noise and other spurious signals. When the signal

is received, the correlator recovers the desired signal and rejects the interference. This is possible because the interference sources are uncorrelated to each channel's unique code. In W-CDMA, the unique code for each channel is a combination of the scrambling code and the orthogonal variable spreading factor (OVSF) code, which are described in the following sections.

Base Station and User Equipment Identification

As in other CDMA systems, in W-CDMA each base transceiver station (BTS) output signal is “scrambled” by multiplying all of its data channels by a unique pseudo noise (PN) code, referred to in the W-CDMA specification as a scrambling code. The UE receiver can distinguish one BTS from another by correlating the received signal spectrum with a scrambling code that is identical to that used in the desired BTS. Similarly, each UE output signal is scrambled with a unique scrambling code that allows the BTS receiver to discern one UE from another. The scrambling codes are applied at a fixed rate of 3.84 Mcps. The scrambling codes are not orthogonal, therefore, some interference can exist between two UEs.

Data Channelization

Besides distinguishing which transmitter is being listened to, a CDMA receiver must further distinguish between the various channels originating from that transmitter. For example, a BTS will transmit unique channels to many mobile users, and each UE receiver must distinguish each of its own channels from all the other channels transmitted by the BTS. In W-CDMA, this function is provided by the channelization codes, also known as OVSF codes.

OVSF codes are orthogonal codes similar to the Walsh codes used in IS-95 and cdma2000. Each channel originating from a W-CDMA BTS or UE is multiplied by a different OVSF codes. In IS-95, Walsh codes are fixed at 64 chips in length; in W-CDMA, the length of these codes, also known as the spreading factor (SF), can be configured from 4 to 512 chips, with the resulting downlink (DL) symbol rate being equal to the system chip rate of 3.84 Mcps divided by the SF. For example a SF of four corresponds to a symbol rate of 960 kbps.

The entire set of OVSF codes is identical for each UE and BTS. The scrambling code allows OVSF code reuse between UE and BTS within the same geographic location. Therefore, it is the combination of OVSF and scrambling codes that provides a unique communication channel between a UE and BTS.

The W-CDMA radio link between the BTS and UE must support multiple simultaneous data channels. For example, a 3G connection may include bi-directional voice, video, packet data, and background signaling messages, each representing a unique data channel within a single frequency carrier.

Figure 4-63 on page 245 illustrates a W-CDMA system with two BTS and four UEs. The scrambling code (SC) provides a unique identity to each UE and each BTS. The OVSF code allocations provide a unique identity to each channel conveyed by a UE or BTS within one cell. For example SC2 identifies BTS 2, and SC6 identifies UE 4. BTS 2 uses OVSF4 and OVSF5 to send voice and signaling information to UE 4. This UE uses OVSF1 and OVSF2 to send voice and signaling information back to BTS 2. Note that other BTSs and UEs also use the same OVSF codes (OVSF1 and OVSF2). This is not a problem since the scrambling codes decorrelate the re-used OVSF codes.

Figure 4-63

W-CDMA Code Allocations

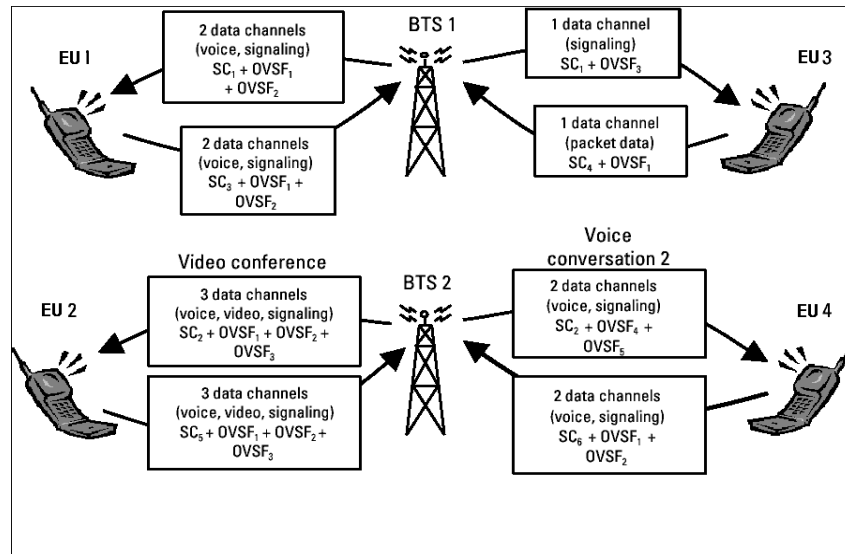

The combination of OVSF codes and scrambling codes provide the signal spreading, and therefore, the spreading gain needed for the receiver correlators to pull the desired signal out of the noise. The SF determines the degree of spreading gain. For high data rate signals, the SF and spreading gain are lower. For the same level of interference, the amplitude for high data rate channels must be higher, in order for all channels to maintain equal energy-per-bit-to-noise ratio (E_b/N_o).

Concepts

W-CDMA Communication System

Figure 4-64

W-CDMA Error Vector Spectrum (Quad-View)

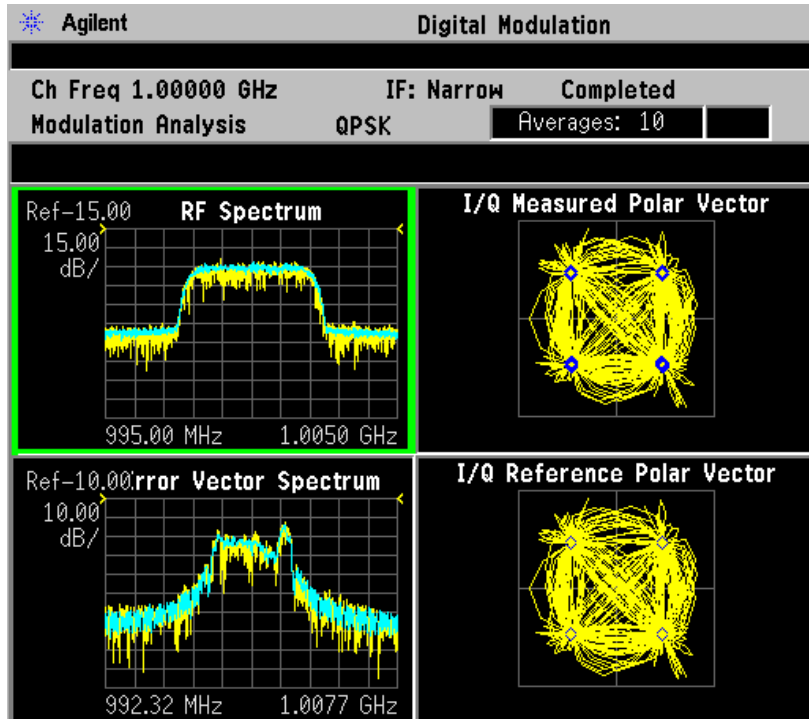

Figure 4-65

W-CDMA Meas Setup Table Example

Agilent		Digital Modulation	
Ch Freq	1.00000 GHz	IF: Narrow	Completed
Modulation Analysis	QPSK	Averages: 10	
Modulation Format QPSK			
Modulation Format	QPSK	Average	On
Meas Filter	Root Nyquist	Avg Number	10
Ref Filter	Nyquist	Average Mode	Repeat
Alpha/BT	0.22	Trace Avg Type	RMS
Symbol Rate	3.840000 MHz	FFT Window Type	Flat Top
Meas Interval	256 symbols	Trig Source	Free Run
IF Band Width	10.00 MHz	Carrier Lock	Normal
IF Band Width Mode	Auto	Sync	None
EQ Filter	Off	Burst Search Th.	-20.00 dB
EQ Filter Length	5	Search Length	10.000000 ms
EQ Convergence	1.000000	Sync Word Length	10 symbols
EQ Hold	Off	Sync Offset	0 symbols
Sync Ptrn	0000		

What Is the cdma2000 Communication System?

Introduction

Code Division Multiple Access 2000 (cdma2000) is a wideband CDMA standard that has been adopted by 3GPP2. It provides a wideband air interface for third generation global wireless communications systems. cdma2000 is a derivative of the IS-95-B CDMA system, also known as cdmaOne, and provides an upgrade path to support IMT-2000. This section will present the basics of cdma2000 as it differs from IS-95, and will assume the reader has some familiarity with IS-95 technology.

cdma2000 is defined in the following Telecommunications Industry Association (TIA) and Electronics Industry Alliance (EIA) document: TIA/EIA/IS-2000-1 through TIA/EIA/IS-2000-6.

cdma2000 relies on the Global Positioning System (GPS) for intercell synchronization. Both reverse and forward transmitter power controls are implemented with 1.25 ms intervals. cdma2000 is a direct sequence spread-spectrum digital communications technique that supports wider RF bandwidths from 1.25 to 15 MHz. The main advantages of cdma2000 over other types of digital communication schemes are:

- greater capacity
- immunity to signal loss and degradation due to high-level broadband interference, multipath, and fading
- strict minimization of power consumption for mobile stations by both base station and mobile controls
- support for variable data rates; up to 144 kbits/second for mobile (vehicular) data rate, up to 384 kbits/second for portable (pedestrian) data rate, and up to 2 Mbits/second for fixed installations
- increased security

cdma2000 uses correlative codes to distinguish one user from another. Frequency division is still used, as is done with Frequency Division Multiple Access (FDMA) and Time Division Multiple Access (TDMA), but in a much larger bandwidth such as 1.25 MHz or greater. cdma2000 realizes increased capacity from 1:1 frequency reuse and sectorized cells. The capacity limit is soft. That is, capacity can be increased with some degradation of the error rate or voice quality.

In cdma2000, a single user's channel consists of a specific frequency combined with a unique Walsh code channel. Correlative Walsh codes allow each user to operate in the presence of substantial interference. The interference is the sum of all other users on the same cdma2000 frequency, both from within and outside of the home cell, and from delayed versions of these signals. It also includes the usual thermal noise and atmospheric disturbances. Delayed signals caused by multipath are separately received and combined in cdma2000. One of the major differences in access is that any cdma2000 frequency can be used in all sectors of all cells. This is possible because cdma2000 is

designed to decode the proper signal in the presence of high interference.

Also, cdma2000 offers a number of RF structures to accommodate almost any conceivable application. These options include direct spreading to support those applications where clear spectrum is available and multi-carrier arrangements using 1.25 MHz wide channels to allow overlays with TIA/EIA-95-B systems.

Spreading Rate

Spreading rate (SR) defines the final spread chip rate in terms of 1.2288 Mcps. The two spreading rates are SR1 and SR3. An SR1 signal has a chip rate of 1.2288 Mcps and occupies the same bandwidth as cdmaOne signals. The SR1 system doubles the system capacity; therefore, it can be considered an improved cdmaOne system.

There are two main differences between cdmaOne and cdma2000. The first is fast power control and quadrature phase shift keying (QPSK) modulation rather than dual binary phase shift keying (BPSK) in the forward link. The second difference is the presence of a pilot signal, to allow coherent demodulation, and hybrid phase shift keying (HPSK) spreading in the reverse link.

An SR3 cdma2000 signal has a rate of 3.6864 Mcps (3 x 1.2288 Mcps) and occupies three times the bandwidth of cdmaOne. Originally, the SR3 system appeared to be viable. Upon further investigation the SR3 cdma2000 system was determined to not be viable and is no longer receiving any commercial attention at this time. Therefore, we will not be covering SR3 in this section.

Radio Configuration

Radio configuration (RC) defines the physical channel configuration based upon a specific channel data rate. Each RC specifies a set of data rates based on either 9.6 or 14.4 kbps bit streams, the two existing data rates supported for cdmaOne. Each RC also specifies the spreading rate (either SR1 or SR3) and the physical coding. Currently there are nine radio configurations defined in the cdma2000 system for the forward link and six for the reverse link. Examples include:

- RC1 is the backwards-compatible mode of cdmaOne for 9600-bps voice traffic. It includes 9.6, 4.8, 2.4, and 1.2 kbps data rates and operates at SR1. It does not use any of the cdma2000 coding improvements.
- RC3 is a cdma2000-specific configuration based on 9.6 kbps that also supports 4.8, 2.7, and 1.5 kbps for voice, while supporting data at 19.2, 38.4, 76.8, and 153.6 kbps and operates at SR1. Each base transceiver station (BTS) or MS must be capable of transmitting using different RCs at the same SR. Refer to [1] for detailed information on the different RCs.

Differences between cdma2000 and W-CDMA

The Third-Generation Partnership Project (3GPP) W-CDMA is the other main wideband CDMA technology competing for the 3G cellular market. There has been much discussion about the need to harmonize W-CDMA and cdma2000 in an attempt to facilitate global use of 3G phones. However, even though both systems are based on a similar CDMA technology, they are significantly different. The main differences are:

- spreading rate - (3.84 Mcps for W-CDMA versus 1.2288 Mcps for cdma2000 SR1)
- synchronization and BTS identification methodology - W-CDMA does not use GPS, or Global Positioning System. For information on-CDMA user equipment (UE)¹ design and test issues, refer to [2].

1. W-CDMA specifications use the term UE to refer to mobile phones or other computing devices that provide wireless access to the W-CDMA system.

cdma2000 Communication System

Figure 4-66 cdma2000 Error Vector Spectrum (Quad-View)

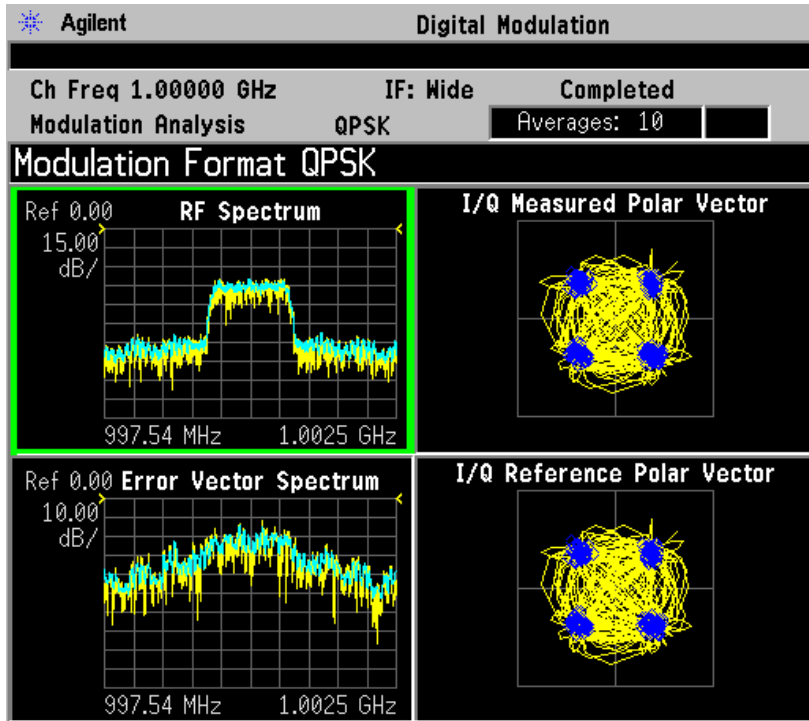

Figure 4-67 cdma2000 Meas Setup Table Example

Agilent Digital Modulation			
Ch Freq	1.00000 GHz	IF: Wide	Completed
Modulation Analysis	QPSK	Averages:	10
Modulation Format QPSK			
Modulation Format	QPSK	Average	On
Meas Filter	CDMA	Avg Number	10
Ref Filter	CDMA	Average Mode	Repeat
Alpha/BT	0.22	Trace Avg Type	RMS
Symbol Rate	1.228800 MHz	FFT Window Type	Flat Top
Meas Interval	200 symbols	Trig Source	Frame
IF Band Width	4.915 MHz	Carrier Lock	Normal
IF Band Width Mode	Auto	Sync	None
EQ Filter	Off	Burst Search Th.	-20.00 dB
EQ Filter Length	5	Search Length	25.000000 ms
EQ Convergence	1.000000	Sync Word Length	10 symbols
EQ Hold	Off	Sync Offset	0 symbols
Sync Ptrn	0000		

What is the NADC Communications System?

The North American Dual-Mode Cellular (NADC) is one of the cellular communications systems. NADC is also referred to as North American Digital Cellular, or American Digital Cellular (ADC). Occasionally it is also referred to as Digital Advanced Mobile Phone Service (D-AMPS) or NADC-TDMA.

The NADC communications system is defined in the Electronics Industry Alliance (EIA) and Telecommunication Industry Association (TIA) standard documents. The following is a list of all relevant and applicable standard documents:

- TIA/EIA IS-136.1
TDMA Cellular/PCS - Radio Interface - Mobile Station - Base Station Compatibility - Digital Control Channel
- TIA/EIA IS-136.2
TDMA Cellular/PCS - Radio Interface - Mobile Station - Base Station Compatibility - Traffic Channels and FSK Control Channel
- TIA/EIA IS-137
TDMA Cellular/PCS - Radio Interface - Minimum Performance Standards for Mobile Stations
- TIA/EIA IS-138
TDMA Cellular/PCS - Radio Interface - Minimum Performance Standards for Base Stations
- TIA/EIA-627
800 MHz Cellular System, TDMA Radio Interface, Dual-Mode Mobile Station - Base Station Compatibility Standard (ANSI/TIA/EIA-627-96), which replaced IS-54-B
- TIA/EIA-628
800 MHz Cellular System, TDMA Radio Interface, Minimum Performance Standards for Dual-Mode Mobile Stations (TIA/EIA-628-96), which replaced IS-55-A
- TIA/EIA-629
800 MHz Cellular System, TDMA Radio Interface, Minimum Performance Standards for Base Stations Supporting Dual-Mode Mobile Stations (ANSI/TIA/EIA-629-96), which replaced IS-56-A

Each base station retains the analog control channels and analog traffic channels of the advanced mobile phone service (AMPS) system. In addition, a base station can have digital traffic channels. The mobile stations are dual mode and access the network via the analog control channel. They are capable of using either analog or digital traffic

channel. Digital control channel and digital only mobile stations are also currently being produced.

The AMPS system and the analog part of the NADC IS-54 system employ a frequency division multiple access (FDMA). FDMA means that each traffic channel is assigned to a separate RF frequency. A pair of frequencies with 45 MHz apart (80 MHz apart for 1900 MHz band) is used to provide full duplex operation of the NADC system. The RF channel spacing is 30 kHz. The modulation for the analog portion is frequency modulation (FM).

The digital part of the NADC system employs a combination of FDMA and time division multiple access (TDMA). The NADC time division multiple access structure allows up to six users to share a single carrier frequency. The TDMA frame structure divides time on a carrier into a stream of frames. Each frame is 40 ms long consisting of 6 timeslots; thus, one timeslot is 6.67 ms long. A digital traffic channel is defined by a carrier frequency (or channel number) and a timeslot number. Each user must transmit data only on his carrier frequency, at a time defined by timeslot number. Currently, 2 timeslots per frame are required for each user because more time is required to transmit voice using full-rate speech codecs presently available. When half-rate speech codecs are incorporated into the system, each traffic channel will require just one timeslot per frame.

NADC digital mobile stations transmit a burst of data when their assigned timeslot occurs. This means a mobile station transmits a burst of amplitude modulation signal, ramping transmission power on and off. An NADC digital base station transmits continuously, switching digital modulation on at the appropriate timeslots.

The digital modulation format used in the NADC system is the $\pi/4$ differential quadrature phase shift keying ($\pi/4$ DQPSK). The $\pi/4$ DQPSK modulation causes both phase and amplitude variations on the RF signal. The quadrature nature of this modulation allows 2 bits to be transmitted at the same time on orthogonal carriers. These 2 bits make one NADC symbol. The digital modulation operates at 162 symbols, or 324 bits in each timeslot. Since there are 1944 bits in 6 timeslots and 25 frames in one second, the transmission bit rate is 48,600 bits per second.

The key objectives of the NADC system are to increase the subscriber capacity, provide more secure voice communications, and be backwards compatible with the existing AMPS analog cellular system.

Since the system transmits all information in a digital form, it will be much harder to listen to someone else's cellular phone conversation. This is a key benefit for people using cellular phones that convey confidential information. The NADC is backwards compatible with the existing AMPS system so that analog cellular phones would not be obsolete. Therefore, all NADC mobiles have the capability to operate using the existing analog base stations as well as the digital base

stations.

Following is a summary of the NADC air interface. Note that the frequency range is the same as the analog cellular. Since it is a dual-mode system, NADC will use the same frequency band currently assigned to the AMPS cellular. The available channels are divided into analog and digital channels. The channel spacing is 30 kHz each, and the RX/TX frequency difference is 45 MHz as in the AMPS cellular. NADC has a RX/TX time spacing of 1.85 ms. It uses the $\pi/4$ DQPSK modulation and the modulation rate is 24.3 ksymbols/sec. NADC will initially allow 3 users per frequency pair and will allow 6 when implemented with the half-rate voice coder. One frame is 40 ms and consists of 6 timeslots that are each 6.667 ms long. There are 162 symbols per timeslot and the symbol period is 41.16 μ s.

800 MHz	Uplink	825.030 to 848.970 MHz	824.040 to 825.000 MHz
	Downlink	870.030 to 893.970 MHz	869.040 to 870.000 MHz
	Channel Numbers	1 to 799	991 to 1023
1900 MHz	Uplink	1850.040 to 1909.920 MHz	
	Downlink	1930.080 to 1989.990 MHz	
	Channel Numbers	2 to 1998	

NADC Communication System

Figure 4-68 NADC Error Vector Spectrum (Quad-View)

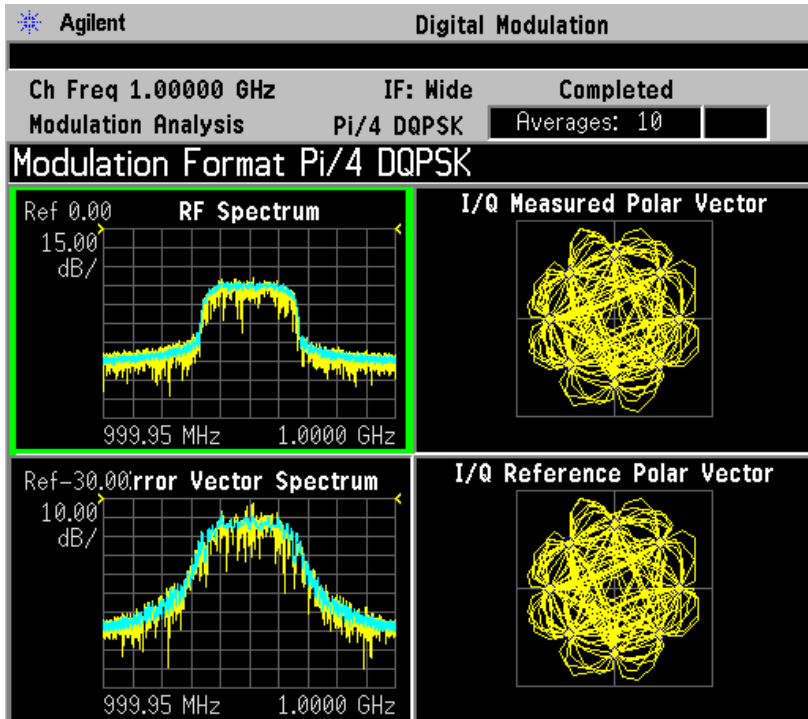

Figure 4-69 NADC Meas Setup Table Example

Agilent		Digital Modulation	
Ch Freq	1.00000 GHz	IF:	Wide
Modulation Analysis	Pi/4 DQPSK	Completed	Averages: 10
Modulation Format Pi/4 DQPSK			
Modulation Format	Pi/4 DQPSK	Average	On
Meas Filter	Root Nyquist	Avg Number	10
Ref Filter	Nyquist	Average Mode	Repeat
Alpha/BT	0.35	Trace Avg Type	RMS
Symbol Rate	24.300 kHz	FFT Window Type	Flat Top
Meas Interval	162 symbols	Trig Source	Frame
IF Band Width	97.20 kHz	Carrier Lock	Normal
IF Band Width Mode	Auto	Sync	None
EQ Filter	Off	Burst Search Th.	-20.00 dB
EQ Filter Length	5	Search Length	49.000000 ms
EQ Convergence	1.000000	Sync Word Length	14 symbols
EQ Hold	Off	Sync Offset	8 symbols
Sync Ptn	A91DE4A		

What is the PDC Communications System?

The PDC communications system is defined in the Research and Development Center for Radio Systems document, RCR STD-27, the Personal Digital Cellular Telecommunication System Standard.

The PDC system is a digital communications system that employs a combination of a frequency division multiple access (FDMA) and a time division multiple access (TDMA). A pair of frequencies (130 or 50 MHz apart in the 800 MHz bands and 48 MHz apart in the 1500 MHz band) is used to provide the full duplex operation with RF channels spacing 50 kHz each with interleaving by 25 kHz.

800 MHz	Uplink	940 to 958 MHz	887 to 889 MHz
	Downlink	810 to 828 MHz	832 to 834 MHz
800 MHz	Uplink	898 to 901 MHz	915 to 940MHz
	Downlink	843 to 846 MHz	860 to 885 MHz
1500 MHz	Uplink	1429 to 1453 MHz	
	Downlink	1477 to 1501 MHz	

One TDMA frame is structured with 6 timeslots, so each channel frequency can support up to 6 timeslots. Currently, two timeslots of each frame are used for one traffic channel, which is required for the full-rate speech codec. When half-rate speech codecs are incorporated into the system, each traffic channel will require just one timeslot per frame. One frame is 40 ms long and each timeslot is 6.667 ms long. Thus, the mobile stations have burst carriers that are turned on for two timeslots (full-rate codec) or one timeslot (half-rate codec). When an RF channel is in use by a digital base station, the base station carrier will be turned on for one entire frame. This is true even if only one traffic channel is in use on that RF channel. However, the carrier power can be different at each timeslot.

The digital modulation format used in the PDC system is $\pi/4$ differential quadrature phase shift keying ($\pi/4$ DQPSK). The $\pi/4$ DQPSK modulation causes both phase and amplitude variations on the RF signal. The quadrature nature of this modulation allows 2 bits to be transmitted at the same time on orthogonal carriers. There are 140 symbol periods in each timeslot, and each symbol contains 2 bits of information. Therefore, there are 280 bits in each timeslot. Since there are 1,680 bits in 6 timeslots and 25 frames in one second, the transmission bit rate is 42,000 bits per second.

PDC Communication System

Figure 4-70 PDC Error Vector Spectrum (Quad-View)

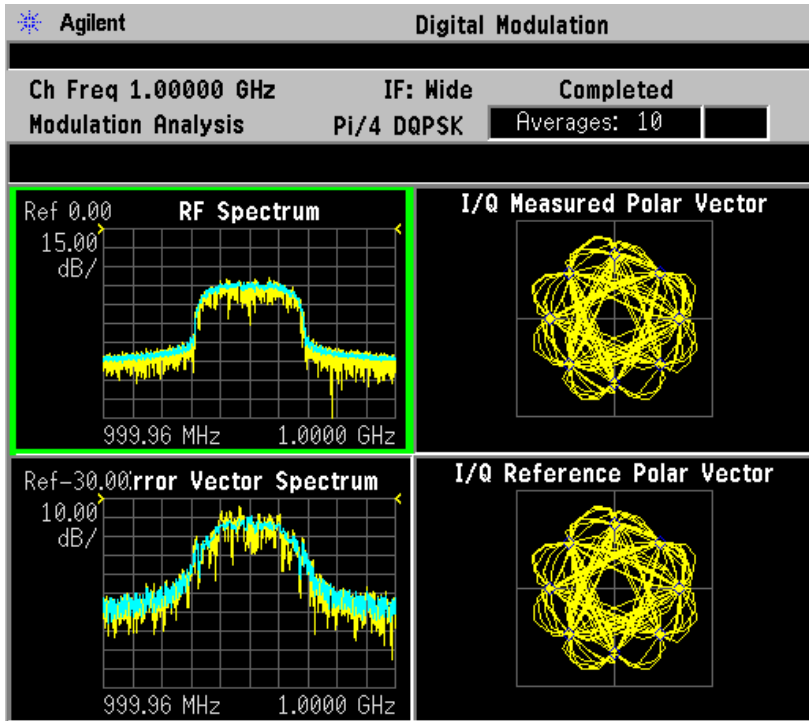

Figure 4-71 PDC Meas Setup Table Example

Agilent Digital Modulation			
Ch Freq	1.00000 GHz	IF: Wide	Completed
Modulation Analysis	Pi/4 DQPSK	Averages:	10
Modulation Format Pi/4 DQPSK			
Modulation Format	Pi/4 DQPSK	Average	On
Meas Filter	Root Nyquist	Avg Number	10
Ref Filter	Nyquist	Average Mode	Repeat
Alpha/BT	0.50	Trace Avg Type	RMS
Symbol Rate	21.000 kHz	FFT Window Type	Flat Top
Meas Interval	138 symbols	Trig Source	Frame
IF Band Width	84.00 kHz	Carrier Lock	Normal
IF Band Width Mode	Auto	Sync	None
EQ Filter	Off	Burst Search Th.	-20.00 dB
EQ Filter Length	5	Search Length	48.000000 ms
EQ Convergence	1.000000	Sync Word Length	10 symbols
EQ Hold	Off	Sync Offset	56 symbols
Sync Ptrn	785B4		

What is the PHS Communication System

PHS

NTT Personal Communications Network Group and DDI Pocket Telephone Group began operation of PHS (personal handy-phone system) services in Tokyo and Sapporo on July 1, 1995. PHS is an effective data transmission means for mobile computing, and allows terminals to be used in virtually any locations at home, outdoors and in the office.

The PHS standard is a TDD-TDMA based low tier micro cellular wireless communications technology operating in the 1880 to 1930 MHz band, now used by millions of subscribers worldwide in public PHS networks, PHS-WLL networks, corporate indoor PBX applications and in the home environment. The cell installation architecture, which uses dynamic channel allocation, requires reduced cell station installation planning and costs for the operators, and can be cost effectively deployed in environments ranging from urban to rural environments.

PHS Communication System

Figure 4-72 PHS Error Vector Spectrum (Quad-View)

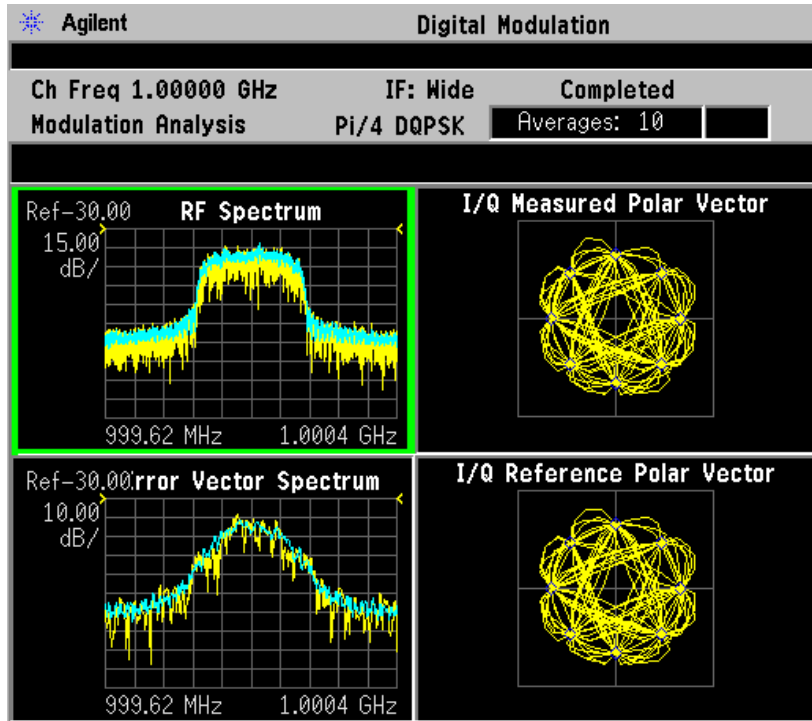

Figure 4-73 PHS Meas Setup Table Example

Agilent Digital Modulation			
Ch Freq 1.00000 GHz		IF: Wide	Completed
Modulation Analysis		Pi/4 DQPSK	Averages: 10
Modulation Format Pi/4 DQPSK			
Modulation Format	Pi/4 DQPSK	Average	On
Meas Filter	Root Nyquist	Avg Number	10
Ref Filter	Nyquist	Average Mode	Repeat
Alpha/BT	0.50	Trace Avg Type	RMS
Symbol Rate	192.000 kHz	FFT Window Type	Flat Top
Meas Interval	111 symbols	Trig Source	Frame
IF Band Width	768.0 kHz	Carrier Lock	Normal
IF Band Width Mode	Auto	Sync	Sync Word Cont
EQ Filter	Off	Burst Search Th.	-20.00 dB
EQ Filter Length	5	Search Length	5.800000 ms
EQ Convergence	1.000000	Sync Word Length	8 symbols
EQ Hold	Off	Sync Offset	4 symbols
Sync Ptrn	3D4C		

What is the TETRA Communications System

TETRA is a digital trunked radio system that can provide voice or data communications between PMR users.

The trunked radio aspects allow the users to only occupy as much of the spectrum as they need to deliver a message. When the radio channel is not conveying information it is made available to others to use. In addition the TETRA network allows one terminal to efficiently communicate with other terminals in ways which are difficult to achieve with the public cellular networks.

The digital modulation format used is $\pi/4$ DQPSK (45 degree phase offset Differential Quaternary Phase Shift Keying), with a root-raised cosine channel filter with an alpha of 0.35 in both the transmitter and the receiver, giving an overall raised cosine filter response. This modulation scheme ensures a highly efficient use of the radio frequency spectrum.

Each radio frequency (RF) carrier is divided into four time slots, which allows up to four users to key their mobile radios to the same carrier frequencies. The RF carriers are spaced at 25 kHz intervals, resulting in very efficient use of the spectrum since each user effectively occupies just 6.25 kHz of spectrum. The use of digital technology ensures good frequency re-use patterns and simulcast networking if required. The air interface data rate is 36 kbits/s (18 ksymbols/s).

The air interface uses a frequency offset between its transmit and receive frequencies - the frequency duplex - the exact difference being network implementation dependent. For public safety applications in the 380 to 400MHz band the duplex is typically 10 MHz.

The TETRA standard uses a digital voice coder/decoder (codec), proposed by SGS Thomson, which reduces the speech information to a low data rate of 4.567 kbits/s. The codec ensures that the speech data is suitable for transmission over the air interface as well as ensuring that voice transmissions are secure from casual eavesdropping. In addition encryption systems are supported to provide even greater levels of security since the transmissions cannot be decoded by only monitoring the air interface.

The standard also allows two mobile terminals to communicate without the presence of any infrastructure (called Direct Mode Operation or DMO). This means that the range of the TETRA system can be

extended outside the normal coverage area - for example aiding the penetration of a building or basement area which would normally have poor coverage. This feature, which is particularly valuable for public safety authorities, is not easily achieved by cellular systems with their fixed infrastructure. Another use of the DMO system is extending the cell coverage by using terminals as repeaters, allowing terminals outside the cell to use terminals, which can communicate with the cell to pass the information on.

Data transmissions are supported by the TETRA standard with both circuit mode data (where the terminal acts as an RF modem) and packet data (based on Internet Protocol). Data can be transmitted in idle slots or even transmitted in more than one time slot per frame to increase the data rate. This is useful for transmitting graphical information (including maps), scanned images (such as fingerprints) or transmitting low bit rate compressed camera images.

The call set up times (300 ms) is very short compared to cellular systems, which is particularly important in high speed transportation systems and emergency situations. Broadcast transmissions to multiple handsets (point to multipoint) are also allowed - a crucial feature for many PMR applications.

The option of adding a SIM (subscriber interface module) card similar to that used in GSM will provide additional services and security for users, including the easy transfer of user set-ups to a replacement radio for maintenance or roaming purposes.

TETRA Communication System

Figure 4-74

TETRA Error Vector Spectrum (Quad-View)

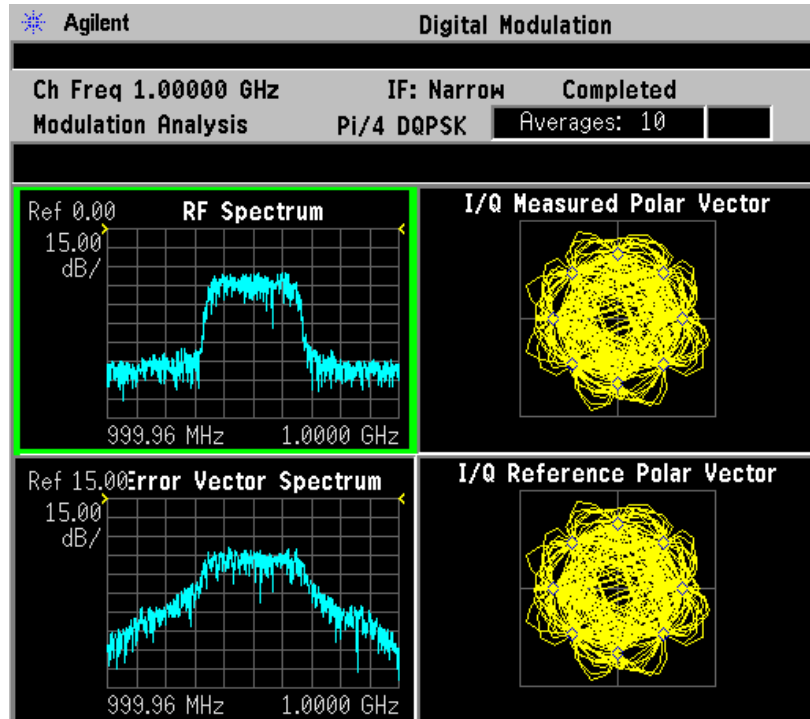

Concepts

Figure 4-75

TETRA Meas Setup Table Example

Agilent		Digital Modulation	
Ch Freq	1.00000 GHz	IF:	Narrow
Modulation Analysis	Pi/4 DQPSK	Completed	Averages: 10
Modulation Format Pi/4 DQPSK			
Modulation Format	Pi/4 DQPSK	Average	On
Meas Filter	Root Nyquist	Avg Number	10
Ref Filter	Nyquist	Average Mode	Repeat
Alpha/BT	0.35	Trace Avg Type	RMS
Symbol Rate	18.000 kHz	FFT Window Type	Flat Top
Meas Interval	246 symbols	Trig Source	Free Run
IF Band Width	72.00 kHz	Carrier Lock	Normal
IF Band Width Mode	Auto	Sync	None
EQ Filter	Off	Burst Search Th.	-20.00 dB
EQ Filter Length	5	Search Length	73.000000 ms
EQ Convergence	1.000000	Sync Word Length	11 symbols
EQ Hold	Off	Sync Offset	110 symbols
Sync Ptrn	343A74		

What is Bluetooth?

Bluetooth is a limited range RF link technology. It is targeted at voice and data transmission between information appliances for home or business environments. The Bluetooth technology eliminates the need for interconnecting cables and enables ad hoc networking among devices.

The Bluetooth system consists of a radio unit, a baseband link control unit, and link management software. It also includes higher-level software utilities that focus on inter operability features and functionality. [Figure 4-76 on page 263](#) is a block diagram for this type of frequency hopping system, showing the baseband controller and the RF transmitter and receiver sections.

Bluetooth devices operate in the 2400 - 2483.5 MHz Industrial, Scientific and Medical (ISM) band. This band is unlicensed and available globally.

The design emphasis is on very low power, extremely low cost, and robust operation in the uncoordinated, interference dominated RF environment of the ISM band.

The range is specified as 10 meters, or 100 meters with an additional 20 dB power amplifier. The maximum data rates for a single link are 432.6/432.6 kbps symmetrical, or 721.0/57.6 kbps asymmetrical. The connection topology is basically a star, with a single master and up to 7 slaves.

The radio unit employs Frequency Hopping Spread Spectrum (FHSS). Frequency hopping is pseudo-random, usually at 1600 hops/sec. The signal is nominally at each hop frequency for one 625 us timeslot. Each pair of time consecutive slots constitutes a time-division duplex (TDD) frame. The first slot contains a master-to-slave burst; the second may contain a slave-to-master burst.

There are 79 Bluetooth channels, each 1 MHz wide. Frequency hopping occurs over all the 79 channels.

Communication is by packet based TDD. Each data packet has a preamble / header / payload format. Various packet types are defined. Various levels of error correction and link security are supported. Circuit and packet modes of operation are supported. Digitized audio and data are supported. Procedures for link control are defined.

Bluetooth Radio Unit

The Bluetooth radio unit is shown in [Figure 4-76 on page 263](#) as the transmitter and receiver sections of the block diagram. The transmitter up converts the baseband information to the frequency-modulated carrier. Frequency hopping and bursting are performed at this level. Conversely, the receiver down converts and demodulates the RF signal. [Table 4-76 on page 263](#) summarizes some of the key RF characteristics

of Bluetooth.

Figure 4-76

Bluetooth radio block diagram

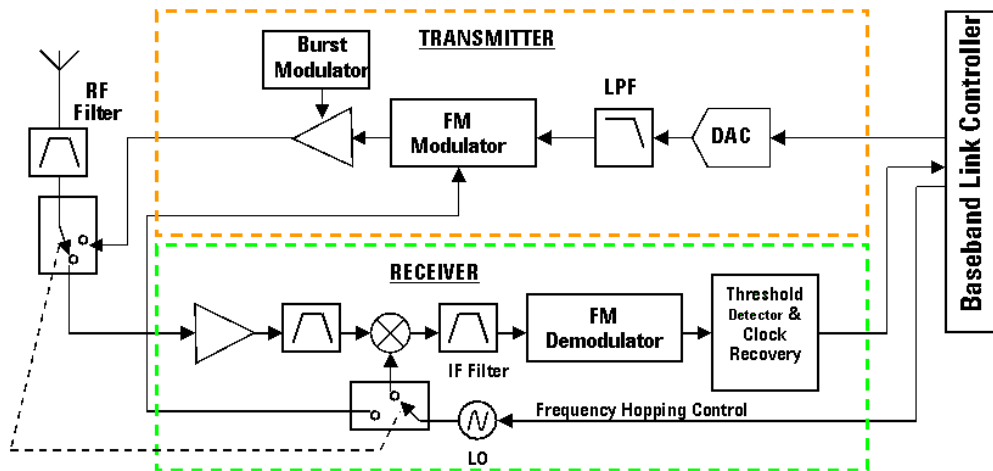

Concepts

Table 4-4 Bluetooth RF Characteristics

Characteristic	Specification	Notes
Carrier Frequency	2400 to 2483.5 MHz (ISM radio band)	$f=2402+k$ MHz, $k=0,\dots,78$
Modulation	0.5 BT Gaussian-filtered 2FSK at 1 Msymbol/s Modulation index: 0.28 to 0.35 (0.32 nominal)	Digital FM scheme The peak frequency deviation allowed is 175 kHz

Table 4-4 Bluetooth RF Characteristics

Characteristic	Specification	Notes
Hopping	<p>1600 hops/s (in normal operation)^a</p> <p>1 MHz channel spacing</p> <p>The system has 5 different hopping sequences:</p> <ol style="list-style-type: none"> 1) Page hopping sequence 2) Page response sequence 3) Inquiry sequence 4) Inquiry response sequence 5) Channel hopping sequence <p>The first four are restricted hopping sequences used during connection setup. The normal channel hopping sequence is pseudorandom based on the master clock value and device address.</p>	<p>The channel hopping sequence is designed to visit each frequency regularly and with roughly equal probability. It has a periodicity of 23 hours and 18 minutes.</p>
Transmit Power	<p>Power Class 1: 1 mW (0 dBm) to 100 mW (+20 dBm)</p> <p>Power Class 2: 0.25 mW (-6 dBm) to 2.5 mW (+4 dBm)</p> <p>Power Class 3: 1 mW (0 dBm)</p>	<p>Class 1 power control: +4 to +20 dBm (required) -30 to 0 dBm (optional)</p> <p>Class 2 power control: -30 to 0 dBm (optional)</p> <p>Class 3 power control: -30 to 0 dBm (optional)</p>
Operating Range	<p>10 cm to 10 m (100 m with Power Class 1)</p>	
Maximum Data Throughput	<p>The asynchronous channel can support an asymmetric link of maximally 721 kbps in either direction while permitting 57.6 kb/s in the return direction, or a 432.6 kbps symmetric link.</p>	<p>Data throughput is lower than the 1 Msymbol/s rate as a result of the overhead, which is inherent in the protocol.</p>

a. Hop speed may vary depending on packet length.

Bluetooth Communication System

Figure 4-77

Bluetooth Error Vector Spectrum (Quad-View)

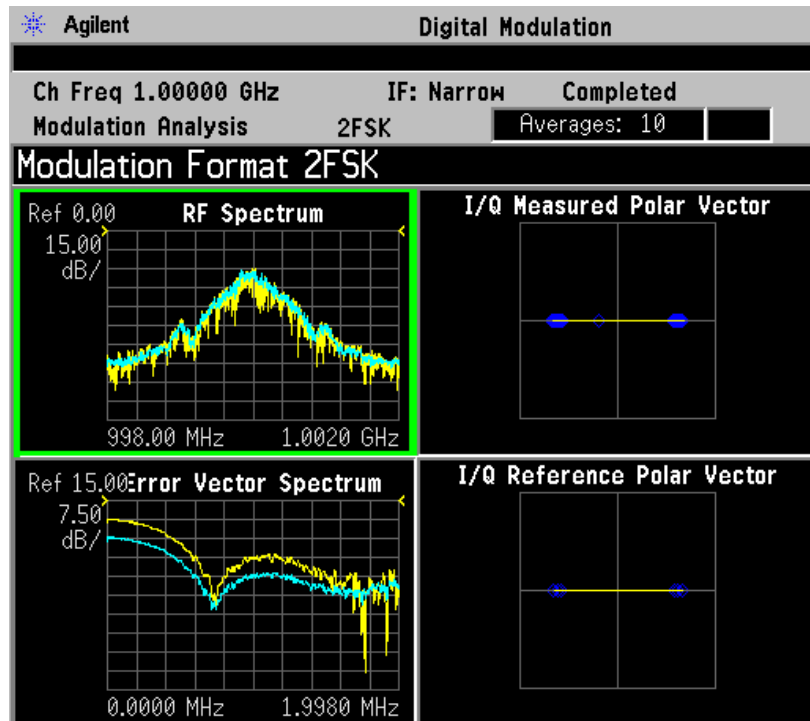

Figure 4-78

Bluetooth Meas Setup Table Example

Agilent Digital Modulation			
Ch Freq 1.00000 GHz		IF: Narrow	Completed
Modulation Analysis		2FSK	Averages: 10
Modulation Format 2FSK			
Modulation Format	2FSK	Average	On
Meas Filter	No Filter	Avg Number	10
Ref Filter	Gaussian	Average Mode	Repeat
Alpha/BT	0.50	Trace Avg Type	RMS
Symbol Rate	1.000000 MHz	FFT Window Type	Flat Top
Meas Interval	320 symbols	Trig Source	Free Run
IF Band Width	4.000 MHz	Carrier Lock	Normal
IF Band Width Mode	Auto	Sync	None
EQ Filter	Off	Burst Search Th.	-20.00 dB
EQ Filter Length	5	Search Length	1.700000 ms
EQ Convergence	1.000000	Sync Word Length	10 symbols
EQ Hold	Off	Sync Offset	0 symbols
Sync Ptrn	0000		

What are GSM and EDGE?

The Global System for Mobile communication (GSM) digital communications standard defines a voice and data over-air interface between a mobile radio and the system infrastructure. This standard was designed as the basis for a radio communications system. A base station control center (BSC) is linked to multiple base transceiver station (BTS) sites that provide the required coverage.

EDGE (Enhanced Data Rates for GSM Evolution) enhances the GSM standard by implementing a new modulation format and filtering designed to provide higher data rates in the same spectrum. EDGE and GSM signals can be transmitted on the same frequency, occupying different timeslots, and both use existing GSM equipment. EDGE has also been adopted as the basis for IS-136HS.

GSM 450, GSM 480, GSM 850, GSM 900, DCS 1800, and PCS 1900 are GSM-defined frequency bands. The term GSM 900 is used for any GSM system operating in the 900 MHz band, which includes P-GSM, E-GSM, and R-GSM. Primary (or standard) GSM 900 band (P-GSM) is the original GSM band. Extended GSM 900 band (E-GSM) includes all the P-GSM band plus an additional 50 channels. Railway GSM 900 band (R-GSM) includes all the E-GSM band plus additional channels. DCS 1800 is an adaptation of GSM 900, created to allow for smaller cell sizes for higher system capacity. PCS 1900 is intended to be identical to DCS 1800 except for frequency allocation and power levels. The term GSM 1800 is sometimes used for DCS 1800, and the term GSM 1900 is sometimes used for PCS 1900. The following documents detail the standards used when testing:

Table 4-5 Documents detailing the GSM/EDGE standards used:

	GSM-450 GSM-480 GSM-850 GSM-900	DCS-1800	PCS-1900
Mobile station	ETS 300 607-1 (11.10)	ETS 300 607-1 (11.10)	J-STD-007
Base station	ETS 300 609-1 (11.21)	ETS 300 609-1 (11.21)	J-STD-007
Radio transmission and reception	ETS 300 910 (5.05)	ETS 300 910 (5.05)	J-STD-007

NOTE

These standards are continually being updated by the communications industry.

The GSM digital communications standard employs an 8:1 Time Division Multiple Access (TDMA) allowing eight channels to use one carrier frequency simultaneously. The 270.833 kbits/second raw bit rate

is modulated on the RF carrier using Gaussian Minimum Shift Keying (GMSK).

The standard includes multiple traffic channels, a control channel, and a cell broadcast channel. The GSM specification defines a channel spacing of 200 kHz.

Table 4-6 EDGE and GSM Band Data

	P-GSM (GSM 900)	E-GSM (GSM 900)	R-GSM (GSM 900)	DCS 1800 (GSM 1800)	PCS 1900 (GSM 1900)	GSM 450	GSM 480	GSM 700	GSM 850
Uplink (MS Transmit)	890 to 915 MHz	880 to 915 MHz	876 to 915 MHz	1710 to 1785 MHz	1850 to 1910 MHz	450.4 to 457.6 MHz	478.8 to 486 MHz	777 to 792 MHz	824 to 849 MHz
Downlink (BTS Transmit)	935 to 960 MHz	925 to 960 MHz	921 to 960 MHz	1805 to 1880 MHz	1930 to 1990 MHz	460.4 to 467.6 MHz	488.8 to 496 MHz	747 to 762 MHz	869 to 894 MHz
Range (ARFCN)	1 to 124	0 to 124 and 975 to 1023	1 to 124 and 955 to 1023	512 to 885	512 to 810	259 to 293	306 to 340	438 to 511	128 to 251
TX/RX Spacing (Freq.)	45 MHz	45 MHz	45 MHz	95 MHz	80 MHz	45 MHz	45 MHz	30 MHz	45 MHz
TX/RX Spacing (Time)	3 timeslot s	3 timeslot s	3 timeslot s	3 timeslot s	3 timeslot s	3 timeslot s	3 timeslot s	3 timeslot s	3 timeslot s
Modulation Data Rate GMSK (kbits/s) 8PSK (kbits/s):	270.833 812.499	270.833 812.499	270.833 812.499	270.833 812.499	270.833 812.499	270.833 812.499	270.833 812.499	270.833 812.499	270.833 812.499
Frame Period	4.615 ms	4.615 ms	4.615 ms	4.615 ms	4.615 ms	4.615 ms	4.615 ms	4.615 ms	4.615 ms
Timeslot Period	576.9 μ s	576.9 μ s	576.9 μ s	576.9 μ s	576.9 μ s	576.9 μ s	576.9 μ s	576.9 μ s	576.9 μ s
GSM Bit and Symbol Period	3.692 μ s	3.692 μ s	3.692 μ s	3.692 μ s	3.692 μ s	3.692 μ s	3.692 μ s	3.692 μ s	3.692 μ s
EDGE Symbol Period	3.692 μ s	3.692 μ s	3.692 μ s	3.692 μ s	3.692 μ s	3.692 μ s	3.692 μ s	3.692 μ s	3.692 μ s
Modulation GSM EDGE	0.3 GMSK $3\pi/8$ 8PSK	0.3 GMSK $3\pi/8$ 8PSK	0.3 GMSK $3\pi/8$ 8PSK	0.3 GMSK $3\pi/8$ 8PSK	0.3 GMSK $3\pi/8$ 8PSK	0.3 GMSK $3\pi/8$ 8PSK	0.3 GMSK $3\pi/8$ 8PSK	0.3 GMSK $3\pi/8$ 8PSK	0.3 GMSK $3\pi/8$ 8PSK
Channel Spacing	200 kHz	200 kHz	200 kHz	200 kHz	200 kHz	200 kHz	200 kHz	200 kHz	200 kHz

Table 4-6 EDGE and GSM Band Data

	P-GSM (GSM 900)	E-GSM (GSM 900)	R-GSM (GSM 900)	DCS 1800 (GSM 1800)	PCS 1900 (GSM 1900)	GSM 450	GSM 480	GSM 700	GSM 850
TDMA Mux	8	8	8	8	8	8	8	8	8
Voice Coder Bit Rate	13 kbits/s	13 kbits/s, 5.6 kbits/s	13 kbits/s	13 kbits/s	13 kbits/s	13 kbits/s	13 kbits/s	13 kbits/s	13 kbits/s

The framing structure for GSM and EDGE measurements is based on a hierarchical system consisting of timeslots, TDMA frames, multiframe, superframes, and hyperframes. One timeslot consists of 156.25 (157) symbol periods including tail, training sequence, encryption, guard time, and data bits. Eight of these timeslots make up one TDMA frame. Either 26 or 51 TDMA frames make up one multiframe. Frames 13 and 26 in the 26 frame multiframe are dedicated to control channel signaling.

These principles of the GSM systems lead to the need for the fundamental transmitter measurements such as:

- Power vs Time - which verifies that the transmitter output power has the correct amplitude, shape, and timing for the TDMA sequence.
- Phase and Frequency Error - which verifies the accuracy of the transmitters 0.3 GMSK modulation process.
- Output RF Spectrum - which verifies that the RF carrier is contained within the designated 200 kHz channel.

Mobile Stations and Base Transceiver Stations

The cellular system includes the following:

- base transceiver stations, referred to as BTS
(frequency ranges dependent on the standard; refer to)
- mobile stations, referred to as MS
(frequency ranges dependent on the standard; refer to)

Uplink and Downlink

Uplink is defined as the path from the mobile station to the base transceiver station. Downlink is the path from the base transceiver station to the mobile station.

What is an ARFCN?

An ARFCN is the Absolute Radio Frequency Channel Number used in the GSM system. Each RF channel is shared by up to eight mobile stations using Time Division Multiple Access (TDMA). The ARFCN is

an integer (in a range dependent on the chosen standard) which designates the carrier frequency.

What Is A Timeslot?

GSM utilizes Time Division Multiple Access (TDMA) with eight time slots per RF channel which allows eight users to use a single carrier frequency simultaneously. Users avoid one another by transmitting in series. The eight users can transmit once every 4.62 ms for 1 timeslot which is 577 μ s long. The eight user timeslots are numbered from 0 to 7.

Typically, each 577 μ s timeslot has a length of 156.25 bit periods, which consists of 148 data bits and 8.25 guard bits. The 4.62 ms required to cycle through eight timeslots is called a frame. In a TDMA system, the shape of each transmitted burst must be controlled carefully to avoid over-lapping bursts in time.

EDGE Communication System

Figure 4-79

EDGE Error Vector Spectrum (Quad-View)

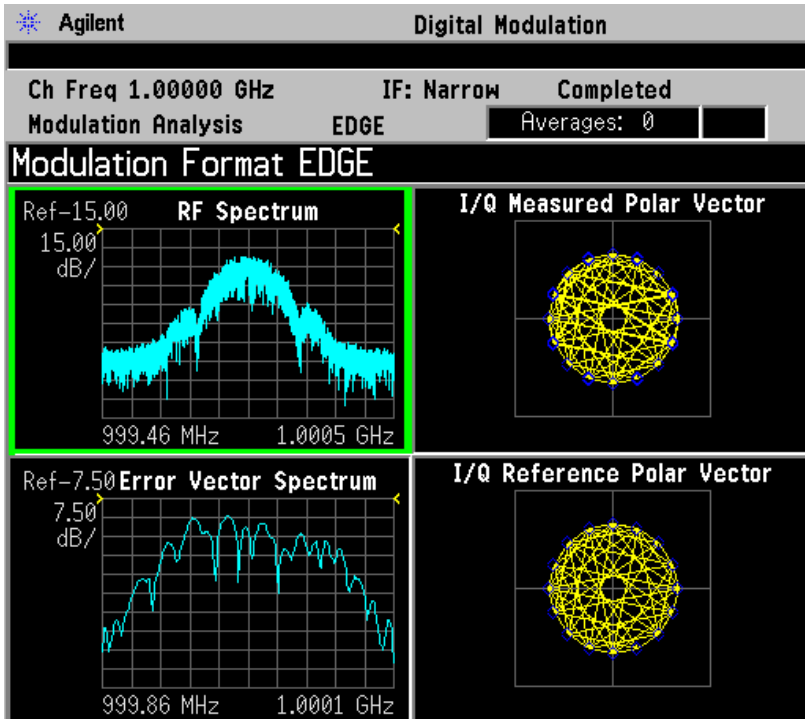

Figure 4-80

EDGE Meas Setup Table Example

Agilent		Digital Modulation	
Ch Freq	1.00000 GHz	IF: Narrow	Completed
Modulation Analysis	EDGE	Averages:	0
Modulation Format EDGE			
Modulation Format	EDGE	Average	On
Meas Filter	EMF	Avg Number	10
Ref Filter	EDGE	Average Mode	Repeat
Alpha/BT	0.25	Trace Avg Type	RMS
Symbol Rate	270.833 kHz	FFT Window Type	Flat Top
Meas Interval	142 symbols	Trig Source	Free Run
IF Band Width	1.083 MHz	Carrier Lock	Normal
IF Band Width Mode	Auto	Sync	Sync Word Burst
EQ Filter	Off	Burst Search Th.	-20.00 dB
EQ Filter Length	5	Search Length	5.300000 ms
EQ Convergence	1.000000	Sync Word Length	26 symbols
EQ Hold	Off	Sync Offset	58 symbols
Sync Ptrn	3F3F9E49FFF3FF3F9E49		

What is APCO25 phase 1?

APCO25 is Project 25, a joint effort of APCO, the Association of Public-Safety Communications Officials, International, Inc. and the National Association of State Telecommunications Directors. APCO25 phase 1 is a digital trunked radio system that uses FDMA, Frequency Division Multiple Access modulation. Phase 1 is a modulation format in which individual carriers are modulated using 9600 baud FSK for the forward link and methods known as C4FM (a 4FSK scheme) and CQPSK (a 25QAM scheme) for the reverse link.

FEATURES OF APCO25 phase 1

6.25 kHz Bandwidth (CQPSK) Modulation The QPSK, or QPSK-C, modulator consists of a table look-up, the two outputs of which (I and Q) are Nyquist filtered and then amplitude modulated, in phase and quadrature phase, before summing. The information bits are processed by the look-up table to yield a 5-level I signal and a 5-level Q signal. The I and Q signals are filtered with the Nyquist Raised Cosine Filter previously described. The I signal is then multiplied by the carrier and the Q signal is multiplied by the carrier after it has been delayed by 90 degrees. The modulated I and Q carriers are then summed together to yield the modulator output.

The C4FM modulator consists of a Nyquist Raised Cosine Filter, cascaded with a shaping filter, cascaded with a frequency modulator.

Addressing A very large number of radio addresses are provided, both for individual radios and talk-groups.

Aggregate Bit Rate The aggregate bit rate is 9600 bits/s. In the case of data transmission, data packets basically consist of a header, containing overhead information, followed by data. In the case of digitized voice transmission, after the transmission of a header containing error protected overhead information, 2400 bits/s is devoted to periodically repeating the overhead information needed to allow for late entry (or the missed reception of the header).

C4FM Frequency Modulator The deviation is +1.8 kHz for dibit 01, +0.6 kHz for dibit 00, -0.6 kHz for dibit 10, and -1.8 kHz for dibit 11.

C4FM Nyquist Filter The dibits of information (i.e., 4800 symbols) are filtered with a raised cosine filter which satisfies the Nyquist criterion minimizing inter-symbol interference. The group delay of the filter is flat over the pass-band for $|f| < 2880$ Hz. The magnitude response of the filter is approximately 1 for $|f| < 1920$ Hz, $0.5 + 0.5 \cos(2(f/1920))$ for $1920 \text{ Hz} < |f| < 2880$ Hz, and 0 for $|f| > 2880$ Hz.

C4FM Shaping Filter The shaping filter has a flat group delay over the band-pass for $|f| < 2880$ Hz. The magnitude response of the filter for $|f| < 2880$ Hz is $\sin(\pi f/4800)/(\pi f/4800)$.

Data Packet Data Blocks Confirmed Data Blocks contain a 7-bit

serial number (to allow for selective transmission), 9 bits of error detection on the entire block, and 14 octets of data. Unconfirmed Data Blocks contain 12 octets of data (note: a 32-bit error detection code is appended to the end of all data packets).

Data Packet Error Correction Header Blocks normally use a rate 1/2 trellis coder for error correction. Unconfirmed data packets normally use a rate 1/2 trellis coder, while confirmed data packets normally use a rate 3/4 trellis coder. Interleaving is applied over Data Blocks.

Data Packet Header The Header Block used for communications between a radio and a packet data node (i.e., switch) contains 10 octets of address and control information, followed by 2 octets of error detection coding. Information contained in the header includes: the identity of the Service Access Point to which the data is being directed, a manufacturers identification (to allow for non-standard functions), a logical link identifier to identify the sending radio of an inbound packet to a node and the receiving radio of a packet outbound from a node, the number of blocks to follow in the packet, the number of pad octets to fill out the last block, the sequence number of the packet, and the Fragment sequence number. For packet data communications directly between two radios, essentially two 12-octet Header Blocks are used at the beginning of each packet in order to convey the necessary address and control information. The header is preceded by 48 bits of synchronization and 64 bits of network identifier (to prevent confusion between radios in different networks).

Data Packet Structure Data messages are divided into Fragments of less than 512 octets. Fragments are, in turn, divided into Blocks of M octets, where M=12 for unconfirmed messages and M=16 for confirmed messages (except Header Blocks are 12 octets in length). Note: a Fragment, preceded by header information, is defined as a Data Packet.

Demodulator The demodulator is capable of receiving both the C4FM and the CQPSK signals. It consists of a frequency modulation detector, followed by an Integrate and Dump Filter and then a stochastic gradient clock recovery device. The Integrate and Dump Filter has a flat group delay over the band-pass for $|f| < 2880$ Hz. The magnitude response of the Integrate and Dump Filter, for $|f| < 2880$ Hz, is approximately $\sin(\pi f/4800)/(\pi f/4800)$.

Digitized Voice Coder Method After evaluating several candidates, APCO25 selected IMBE (Improved MultiBand Excitation) vocoder, operating at 4400 bits/s. An additional 2800 bits/s of forward error correction is added, for error correction of the digitized voice. IMBE has also been selected by INMARSAT, for use in digital voice maritime satellite communications.

Digitized Voice Frame Structure The Header Word, transmitted at the start of every transmission, contains 120 bits of information and 528 bits of error correction. Voice Frames are 180 ms in length and

pairs of Voice frames compose a 360 ms Superframe. The first of a pair of voice frames transmits, in addition to digitized voice and its error corrective coding, 72 bits of link control information, 168 bits of error corrective coding on the link control information, and 16 bits of embedded low-speed data signaling with 16 bits of error corrective coding. The second of the pair of voice frames transmits an additional 16 bits of low-speed data signaling with 16 bits of error corrective coding, 96 bits of encipherment information, and 144 bits of error protective coding on the encipherment information.

Digitized Voice Header Word The header is preceded by 48 bits of synchronization signal and a 64-bit network identifier (to prevent confusion between radios in different networks). The 120 bits of information in the Header Word consists of 72 bits for the encipherment initialization vector, 8 bits for a manufacturer identifier, 8 bits to identify the encipherment algorithm, 16 bits to identify which encipherment key variable is being employed (in systems with multiple encipherment key variables), and 16 bits for the talkgroup address. Including error corrective coding, status symbols (22 bits) not described in this brief contribution, and preceding signaling, the header requires 82.5 ms for transmission.

Digitized Voice Encryption Information The 96 bits of encipherment information consist of the three encipherment-related fields in the header: the 72-bit encipherment initialization vector, the 8-bit encipherment algorithm identifier, and the 16-bit encipherment key variable identifier. The encipherment information is protected by 144 bits of error corrective coding. Note: the encipherment process does not change during a transmission. The repeating of this information every 360 ms is primarily for late-entry by receiving radios.

Digitized Voice Link Control Information As previously stated, 72 bits of link control information is contained in the first of each pair of Voice Frames. If the addressee is a talk-group, the link control information consists of 1 octet describing the type of information (e.g., talk-group type of transmission), 1 octet containing the manufacturer identifier, 1 bit indicating whether or not the transmission is of an emergency nature, 15 bits reserved for future use, 2 octets for the talk-group address, and 3 octets for the transmitting radio's identifier. If the addressee is another radio, the last 7 of the 9 octets consist of: 1 octet reserved for future use, 3 octets for the destination radio's identifier, and 3 octets for the transmitting radio's identifier. This information is protected with 168 bits of error corrective coding.

Encryption Information required for decoding to take place (including the encoding initialization vector) is transmitted at the beginning of all transmissions, and is embedded in the signaling overhead throughout all digitized voice transmissions. This allows for the use of multiple encoding algorithms and "key variables". An adequate number of bits have been assigned to allow for even the highest (i.e., most secure) levels of encoding.

Error Protection To provide for the maximum possible coverage (that is, range of operation), a high degree of forward error correction and interleaving has been provided for. The mobile environment is subject to severe Raleigh fading and the APCO25 techniques have been designed to operate in bit error rate environments of up to 7 percent.

Flexible Modulation Method A pair of modulation methods have been selected that utilize a common receiver. The first, which utilizes a constant-envelope 4-level Frequency Modulation (FM) variant, can utilize simple, high-efficiency amplifiers and has emissions that fit within a 12.5 kHz bandwidth. This method will be fielded in most equipment initially. The second, which utilizes a CQPSK variant with amplitude components, requires the use of highly linear or linearized amplifiers and has emissions that fit within a 6.25 kHz bandwidth. (The receiver, common to both, has a 6.25 kHz bandwidth.)

Low-Speed Data With Digitized Voice An 88.9 bit/s low-speed data channel is provided in the digitized voice frame structure. No application is currently defined. One application under discussion is to use the low-speed data channel for the transmission of accurate geographic location information.

Talk-Group Operation Unlike normal telephone operation, all members of a talkgroup can receive the transmissions of all other members of that talk-group. Members of a talk-group do not have to receive the beginning of a digitized voice transmission (i.e., late entry is provided for).

APCO25 phase1 Communication System

Figure 4-81

APCO25 phase1 Error Vector Spectrum (Quad-View)

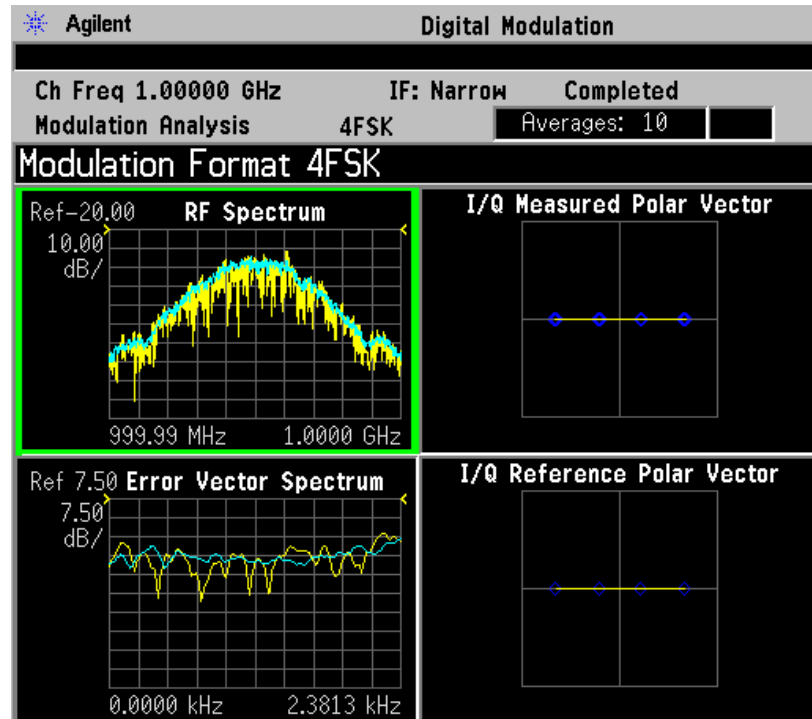

Concepts

Figure 4-82

APCO25 phase1 Meas Setup Table Example

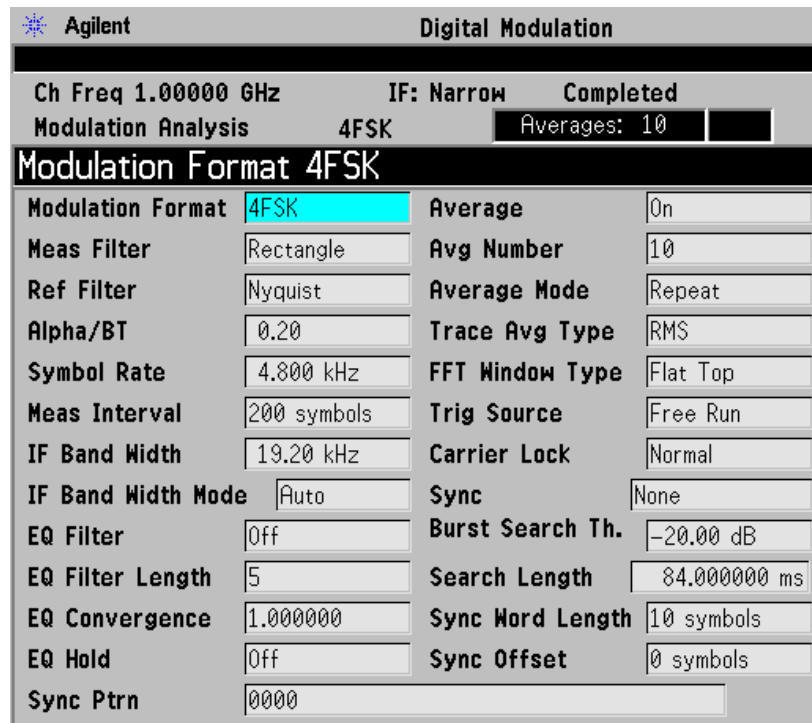

What is VDL Mode 3?

VDL mode 3 stands for VHF Digital Link mode 3, and is a radio system used in the Aeronautical AM band to simultaneously transmit voice and data. The system uses TDMA and individual channels are modulated using D8PSK, differential Phase Shift Keying using 8 states or symbols. Data rates of 31,500 baud are accomplished.

Table 4-7

VDL Mode 3 Characteristics

Modulation Scheme	Channel Spacing	Access Scheme	Data Rate (b/s)	User Traffic Type
D8PSK	25 kHz	TDMA	31,500	AVLC & Digital Voice

What is ZigBee (IEEE 802.15.4)?

ZigBee is the name given to an implementation of the IEEE 802.15.4 communications standard by the ZigBee Alliance. ZigBee is a wireless networking protocol primarily intended for use in LD-PANs, Low Data [R]ate Personal Area Networks. Many applications are being developed, including monitor and control of home, hospital, and building sensors and utilities as well as security and industrial automation.

ZigBee has 3 RF bands of operation as shown below. PSA Option 241 is preset for the 2400-2483.5 (2450) MHz band shown in the first row below.

Table 4-8 ZigBee Characteristics by Frequency Band

Frequency	Spreading Parameters		Data Parameters			
	Chip Rate (kchip/s)	Modulation	Data Rate (kb/s)	Symbol Rate (ksymb/s)	Symbols	Data Chan.
2400-2483.5 MHz	2000	O-QPSK	250	62.5	16-ary Orthogonal	16
868-869.6 MHz	300	BPSK	20	20	Binary	1
902-928 MHz	600	BPSK	40	40	Binary	10

Measurements on Digital RF Communications Systems

Introduction

The previous section presented Communication System Format Standards. Each System Format Standard, detailed the operating parameters associated with that Format. When deploying and maintaining a system, it is important to be able to determine if the system is indeed operating as specified by the system format standard.

This section gives an overview of how the PSA option 241 demodulates a digitally modulated signal for analysis. A description of the three measurement domains is followed by the modulation quality measurements made on the system formats supported by option 241. A review of I/Q, constellation and Eye diagrams is given, in preparation to describing digital modulation errors and signal impairments. The section closes with the displays available to help detect these errors and impairments.

NOTE

PSA option 241 can analyze digital modulation for a single code channel only. If multiple code channels are transmitted, synchronization will fail, and incorrect EVM results will be obtained. For modulation quality measurements of multiple code channels, Modulation Accuracy and Code Domain measurements must be performed by a full-featured standard-based personality, like PSA Option BAF for W-CDMA.

Digital Modulation Analysis

The PSA can be viewed as a measuring receiver. It is really an I/Q receiver, employing techniques similar to most digital radio receivers for decoding digital modulations. However, the difference is the PSA is designed for high-accuracy parametric measurement and display of modulation characteristics. Moreover, the PSA is a measurement tool that can measure and analyze almost every aspect of a digital communications transmitter and receiver system.

Figure 4-83 The PSA as a Receiver

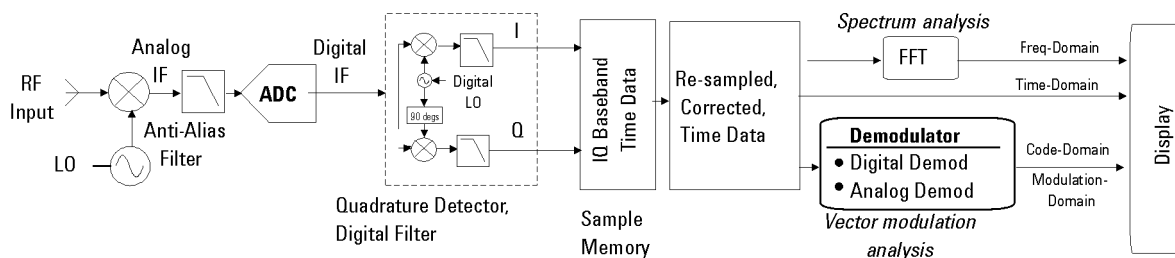

Figure 4-83 shows an Agilent PSA simplified system block diagram. The RF input signal is down converted through several stages of superheterodyne mixing to an IF that can be accurately digitized by the ADC. This digitized IF is then vector (quadrature) detected and digitally filtered—down converted one last time to an I and Q baseband form (I/Q Time data) and stored in RAM. From here, DSP algorithms demodulate the signal—recover the carrier and symbol-clock, apply re-constructive filtering and decoding (recover the original bits). With this DSP software implementation almost any modulation format can be demodulated.

The PSA implementation is different from a radio receiver. The PSA deals with the sampled signals on a block basis; the radio receiver processes data serially, in real time. When you supply the PSA with radio receiver parameters, the PSA in fact synthesizes the receiver via processing in the DSP. It provides all the functions of a receiver down to making analog waveforms. Because the signal has been virtually digitized and placed in memory, it can be post-processed and viewed in any of the time, frequency or modulation domains.

Measurement Domains

The transmitted signal can be viewed in different domains. The time, frequency and modulation domains each provide information about the signal. Time and frequency domain analysis are part of Basic Mode, while digital modulation analysis comes with PSA Option 241.

Complex trade-offs in frequency, phase, timing, and modulation are made for interference-free, multiple-user communications systems. It is necessary to accurately measure parameters in digital RF communications systems to make the right trade-offs. Measurements include analyzing the modulator and demodulator, characterizing the transmitted signal quality, locating causes of high Bit-Error-Rate, and investigating new modulation types.

Time Domain

Traditionally, looking at an electrical signal meant using an oscilloscope to view the signal in the time domain. However, oscilloscopes do not band limit the input signal and have limited dynamic range. Vector signal analyzers downconvert the signal to baseband and sample the I and Q components of the signal. They can display the signal in various coordinate systems, such as amplitude versus time, phase versus time, I or Q versus time, and I/Q polar.

Time-domain analysis is especially important in TDMA technologies, where the shape and timing of the burst must be measured.

Figure 4-84 Time and Frequency Domains

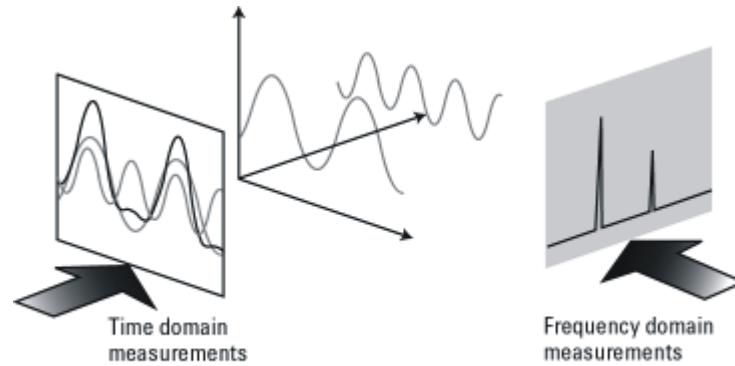

Time Gating

Time-gated spectrum analysis allows you to obtain spectral information about signals occupying the same part of the frequency spectrum that are separated in the time domain. Using an external trigger signal to coordinate the separation of these signals, you can perform the following operations:

- Measure any one of several signals separated in time. For example, you can separate the spectra of two radios time-sharing a single frequency
- Measure the spectrum of a signal in one time slot of a TDMA system
- Exclude the spectrum of interfering signals, such as periodic pulse edge transients that exist for only a limited time

Why time gating is needed:

Traditional frequency-domain spectrum analysis provides only limited information for certain signals. Examples of these difficult-to-analyze signals include the following signal types:

- Pulsed RF
- Time multiplexed
- Time domain multiple access (TDMA)
- Interleaved or intermittent
- Burst modulated

Frequency Domain

Although the time domain provides some information on the RF signal, it does not give us the full picture. The signal can be further analyzed by looking at its frequency components (Figure 4-84).

Frequency measurements are often more complex in digital systems, since factors other than pure tones must be considered. Occupied

bandwidth is an important measurement. It ensures that operators are staying within the bandwidth that they have been allocated. Adjacent channel power (ACP) is also used to detect the effects one user has on other users in nearby channels.

Occupied bandwidth and ACP are available by using the PSA Spectrum Analyzer mode. For more information on these measurements refer to the PSA “Making Measurements” Guide.

Modulation Domain

Modulation accuracy measurements usually involve precision demodulation of a signal and comparison of this demodulated signal with a (mathematically generated) ideal or “reference” signal. The difference between the two is the modulation error, and it can be expressed in a variety of ways. Residual measurements such as this are very powerful for trouble-shooting. Once the reference signal has been subtracted, it is easier to see small errors that may have been swamped or obscured by the modulation itself. The error signal itself can be examined in many ways, in the time domain or (since it is a vector quantity) in terms of its I/Q or magnitude/ phase components. A frequency transformation can also be performed and the spectral composition of the error signal alone can be viewed.

Demodulation involves applying the appropriate filtering before recovering the baseband I and Q signals and sampling these signals at the symbol rate to recover the actual symbols.

Various display formats and capabilities can be used to view the baseband signal characteristics and analyze modulation quality:

- I/Q polar (vector) and constellation diagrams.
- Summary table with I/Q quality metrics, such as Error Vector Magnitude (EVM), magnitude error, phase error, frequency error, rho and I/Q offset.
- Magnitude of the error vector versus time and error vector versus frequency (error vector spectrum).
- Magnitude error and phase error versus time or frequency.
- Eye diagrams.
- Equalization, which allows frequency response and group delay measurements.

Combinations of the display formats and capabilities above can be used to troubleshoot potential problems in the design.

Examples of modulation and frequency domain signals for many modulation formats can be seen in the section.

PSA Digital Demodulator

The heart of the digital demodulation process in the PSA is the digital demodulator. [Figure 4-85](#) shows a simplified block diagram of the

digital demodulator implementation used in the Agilent PSA. The digital demodulator is a general-purpose demodulator, that requires only a minimum of prior information about the input signal to perform demodulation and can be used on a wide variety of modulation formats. The demodulator provides carrier lock, symbol clock recovery, and bit recovery (decodes the actual encoded 1's and 0's) and produces the I/Q measured waveforms. The demodulator also produces ideal I/Q waveforms that are synthesized from the actual recovered bits—called I/Q Reference waveforms. The I/Q measured and I/Q Reference waveforms are subtracted to produce I/Q error waveforms. The I/Q error waveforms generate the modulation quality data results, which can be viewed in various data formats and display outputs.

Figure 4-85 Digital Demodulation Block Diagram

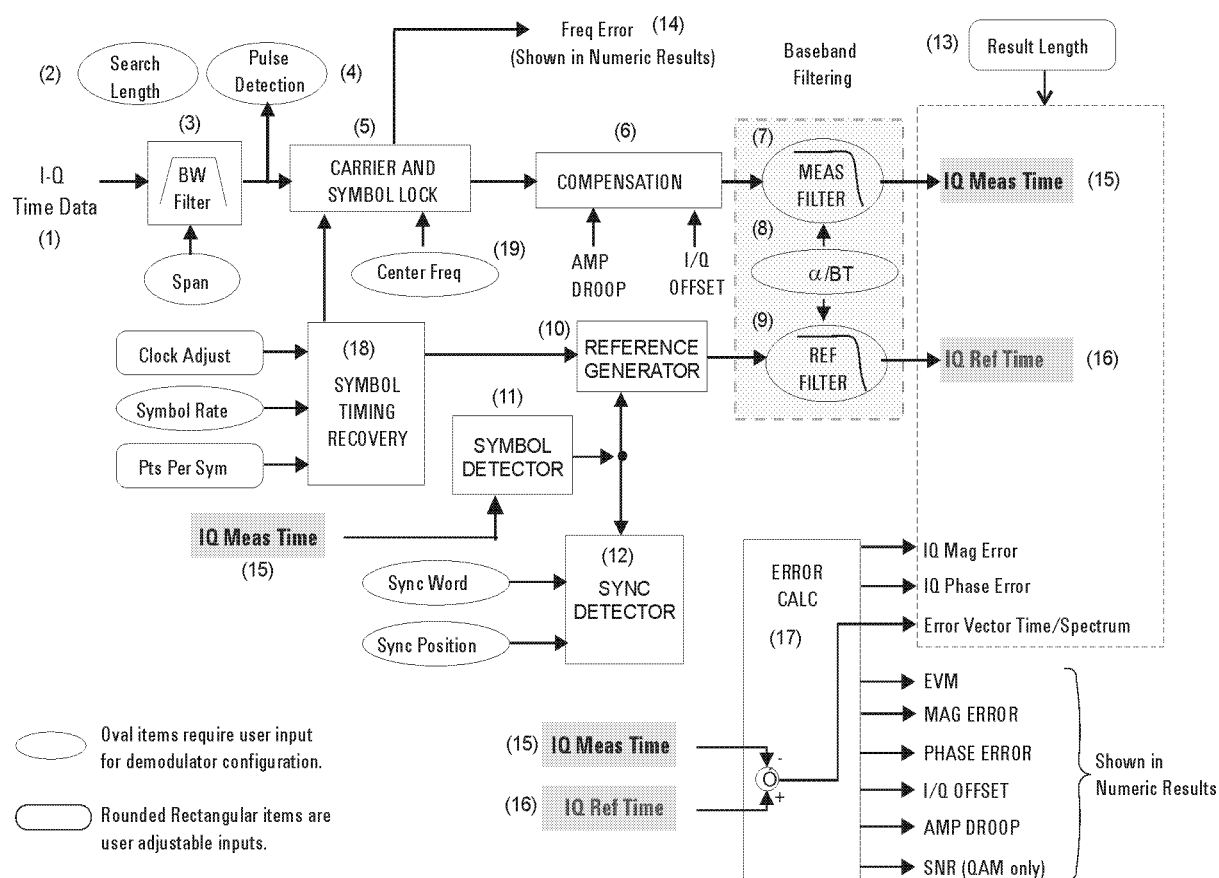

The Digital Demodulator Block Diagram by Section

- Input Signals:** the IF signal is digitized and in I/Q format. These samples also go to the Symbol Detector block.
- Search Length:** this user entry tells the demodulator how many symbols to search through in order to find the user specified synchronization word.

3. **Digital Filter/Decimator:** as seen before in the theory of operation for the vector signal analyzer, based upon your choice of span, excess samples are thrown away or decimated. The digital demodulator has its own separate routine for decimating samples, to ensure that the effective sample rate and timing produce a successful demodulation.
4. **Pulse Detector:** the pulse detector is a handy feature and works as an automatic trigger for burst, I/Q modulated signals. The pulse detector searches for a rise in signal amplitude and then applies the demodulation techniques automatically.
5. **Carrier and Symbol Lock:** when performing an I/Q demodulation without a coherent reference carrier supplied, the receiver must create a phase and timing reference. This block applies inputs of center frequency and symbol rate to recover the carrier and modulation symbol timing from the live modulated carrier.
6. **Compensation:** to further ensure a successful demodulation, this block tests the incoming signal for amplitude droop and IQ offset. Amplitude droop is a measure of the carrier power changing versus time, on a burst carrier. This is compensated for and reported as dB of droop per symbol. IQ offset or origin offset is a function of the amount of carrier feed through. For an ideal modulated signal, the carrier is "nulled" out by the quadrature modulation process making the IQ offset = zero. This value is reported in dB so the ideal case would be minus infinity. Both of these compensated errors are then reported on the Symbol Table/Error Summary.
7. **Measurement Filter:** the filter is specified by type (shape) and bandwidth (alpha or BT). This should be the same filter that would be used by a dedicated receiver, designed to receive and reconstruct the signal under test.
8. **Filter Alpha or BT:** this is a user input to the demodulator setup menu that specifies the required filter bandwidth relative to the symbol rate. Most IQ modulated systems will clearly specify these parameters for the system. The correct filter specification is critical to successful modulation.
9. **Reference Filter:** this filter must be specified, it is the sum of all filtering in the communications system under test. It is the combination of transmitter filtering and receiver filtering. This filter, along with the Reference Generator block will model an ideal reference signal from the signal under test. This reference signal will be the basis for computing the accuracy of the signal under test.
10. **Reference Generator:** this powerful block takes the detected symbols and inputs to the demodulator set up of modulation format, symbol rate and filter specification and computes an ideal model of the incoming signal. This reference will be passed on to the reference filter. The resulting reference signal will be compared to the real signal, to determine the accuracy of modulation.

11. **Symbol Detector:** the symbol detector processes the incoming signal samples and determines what symbols are being transmitted, based upon specifications of modulation format. The resulting symbol stream is passed on to the reference generator for reconstruction into an ideal reference signal.
12. **Sync Detector:** this is a data qualified triggering feature of the digital demodulator. A specific bit pattern (sync word) can be specified with the position of that word relative to the data of interest (trigger delay). The sync detector will then scan the serial bit stream from the symbol detector for that pattern and trigger when it is found.
13. **Result Length:** this user specification determines how many symbols should be demodulated for analysis.
14. **Frequency Error:** this error is the difference between the user-selected center frequency and the actual center frequency measured during the compensation process. The carrier frequency error is reported in the Symbol Table/Error Summary.
15. **IQ Measured Time:** this result is the triggered and synchronized sampled signal under test. It can now be displayed in a number useful ways such as - vector diagrams, constellation diagrams, I and/or Q versus time, etc.
16. **I/Q Reference Time:** this is the idea model of the signal under test. This is what the signal under test would have looked like had it been perfect. It too can be displayed just like a real signal. Its primary use is by the error calc block to compute the error differences between the IQ measured signal and the reference signal.
17. **Error Calculator:** this block takes the two signals, IQ measured time and I/Q reference time and compares them. The result is the comprehensive list of errors shown displayed from here. All of these errors can be displayed and analyzed in a number of useful ways.
18. **Symbol Timing Recovery:** this block looks at your inputs for symbol rate, points per symbol and clock adjust (clock delays) and generates a symbol clock for the demodulator.
19. **Center Frequency:** this is the input for carrier center frequency.

Configuring the Demodulator

The demodulation process begins by configuring the demodulator. The demodulator must be configured to the specific digital modulation format to properly demodulate and analyze the signal. Most analyzers provide a set of standard presets (such as GSM, NADC, cdma2000) that automatically configure the demodulator. In those cases, enter the center frequency, select a standard preset, and the analyzer will demodulate the signal. The PSA, with Option 241 installed, has additional capabilities through a general purpose, user-definable

demodulator. This allows you to customize the demodulator configuration for non-standard formats or troubleshooting purposes. The demodulator block diagram, shown in [Figure 4-85](#), shows the internal demodulator processes (enclosed in rectangular boxes) and the configuration parameters that you can set (enclosed by ovals or rounded rectangular boxes). The items enclosed by an oval identify configuration parameters that are required to define the demodulator for a measurement. The rounded rectangular boxes identify user-adjustable input parameters. At a minimum, the demodulator requires the modulation format (QPSK, FSK, etc.), the symbol rate, the baseband filter type and filter alpha/BT—this set of parameters is generally sufficient for the demodulator to lock to the signal and recover the symbols.

The demodulator uses the configuration inputs and, through DSP, operates on the I/Q Time data received in block format from the analyzers sample memory. The PSA can also receive I/Q Time data from external hardware such as an Agilent ESA analyzer or from a recorded file. The demodulator uses the supplied center frequency and symbol rate to lock to the carrier and recover the symbol clock from the modulated carrier. Note that the demodulator reference clock does not need to be locked with the source clock. The demodulator automatically provides carrier and symbol lock, you do not need to supply an external source-clock input. The signal then goes through a compensation process that applies gain and phase correction. The compensation data is stored and can be viewed in the Error Summary table (such as, amplitude droop and I/Q offset error data). Digital baseband filtering is then applied to recover the baseband I-Q waveforms (I-Q Meas Time data). The recovered I-Q waveforms are applied to a symbol detector that attempts to determine what symbols were transmitted based upon the specified modulation format. From this block of symbols, the serial data bits (1's and 0's) are decoded and recovered.

The reference generator uses the detected symbols in conjunction with the modulation format, the symbol rate, and the specified filtering, to synthesize an ideal set of I/Q reference baseband waveforms (I/Q Ref Time data). Finally, the measured I/Q waveforms and reference I-Q waveforms are compared to produce a host of error characteristics (deviation from perfect) such as phase error, magnitude error, and error vector magnitude (EVM).

Synchronization

Synchronization words (or patterns) are often used to resolve carrier phase ambiguity on non-differential modulation formats. It is important to realize that synchronization words are optional and are not necessary in order to achieve carrier locking.

Sync search lets you use a synchronization pattern to isolate a segment of your signal for display and analysis. The analyzer searches through demodulated data to find your sync pattern, and then uses the Result

Length to determine how much data to display and the Search Offset to display data relative to the sync pattern.

Understanding Burst/Sync Terms

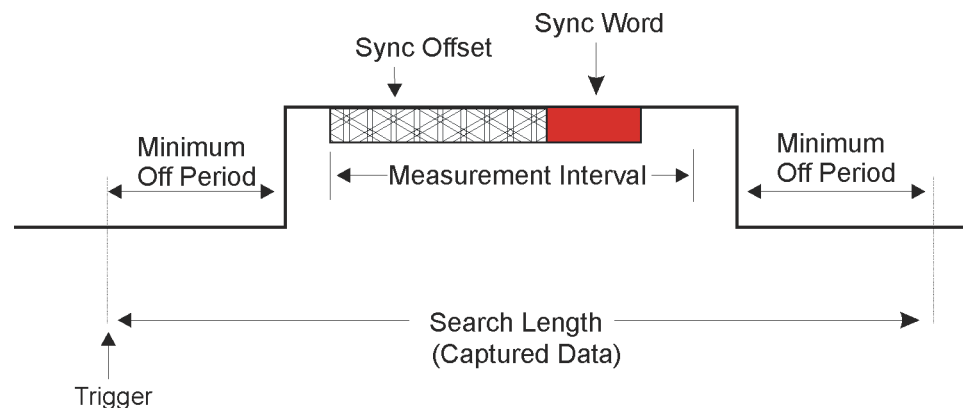

Trigger determines the start of the search length (make sure you include the periods off).

Measurement Interval (Meas Interval key) determines how much data is displayed. The location of the sync word plus the offset determines the position of the measurement interval. This data is used to calculate EVM.

Search Length determines how much data is collected.

An example of **Sync Word** using QPSK as the modulation format would have 2 bits/symbol. The **Sync Pattern** might be A O F 3. The sync word length for this example would be 7 symbols. This means the sync word would be:

$$7 \text{ symbols} \times 2 \text{ bits/symbol} = 14 \text{ bits.}$$

The Sync Word is shown below:

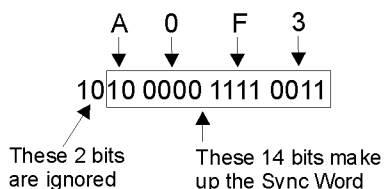

Modulation quality measurements

There are a number of different methods used to measure the quality of a digitally modulated signal. These usually involve precision demodulation of the transmitted signal and comparison of this transmitted signal with a mathematically generated ideal or reference signal, as we saw earlier. The definition of the actual measurement depends mainly on the modulation scheme and standard followed.

- NADC and PDC, for example, use “Error Vector Magnitude (EVM)” on page 287
- GSM uses “Phase and Frequency Errors” on page 289
- cdmaOne uses “Rho” on page 291

Error Vector Magnitude (EVM)

The most widely used modulation quality metric in digital communications systems is error vector magnitude (EVM). The error vector is the vector difference at a given time between the ideal reference signal and the measured signal (Figure 4-86). The error vector is a complex quantity that contains a magnitude and phase component. It is important not to confuse the magnitude of the error vector with the magnitude error, or the phase of the error vector with the phase error.

Expressed another way, the EVM is the residual noise and distortion remaining after an ideal version of the signal has been stripped away.

Figure 4-86

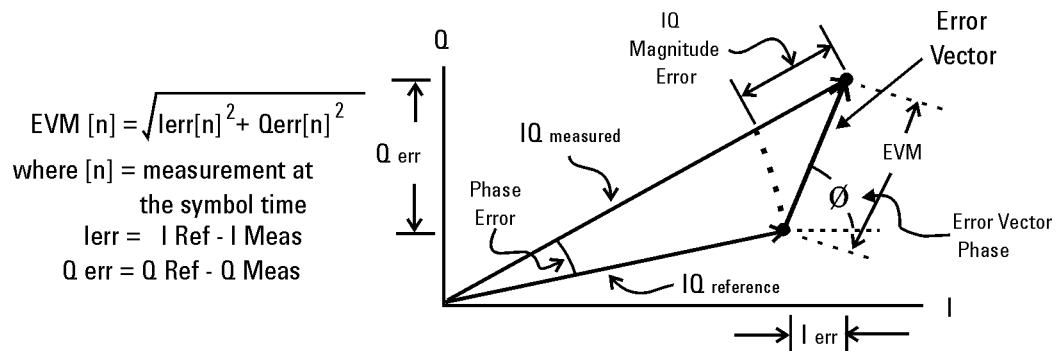

Error Vector Magnitude (EVM) is the difference between the actual measured signal and an ideal reference signal.

EVM is defined as the root mean square (RMS) of the error vector over time at the instants of the symbol clock transitions. By convention, EVM is usually normalized to either the amplitude of the outermost symbol or the square root of the average symbol power. The EVM measurement and the various related data results are sensitive to any signal impairment that affects the magnitude and phase trajectory of a signal for any digital modulation format. This makes it an ideal measurement tool for troubleshooting communications system problems at baseband, IF, or RF sections of the radio transmitter.

Equalization with EVM

The value of EVM as an indicator of modulation quality can be enhanced by the use of equalization in the measuring instrument. Equalization is commonly used in digital communications receivers. Although its primary function is to reduce the effects of multipath, it also compensates for certain signal imperfections generated in both the

transmitter and receiver. For this reason, it is useful to have an equalizer in the measuring instrument.

An instrument with an equalizer will better emulate a receiver; that is, the impairments that the equalizer of the receiver removes are also removed by the measuring instrument. Therefore, the impairments that have little effect on system performance also minimally impact the measured EVM. Figure 4-87 and Figure 4-88 show the magnitude of the error vector versus time without and with equalization. With equalization the constellation looks much better and the magnitude of the error vector versus time is lower. The signal has not changed, only the measurement technique.

Figure 4-87 Without Equalization

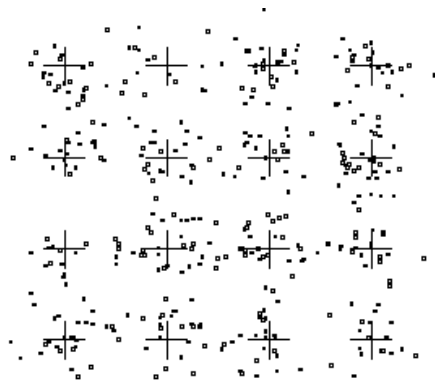
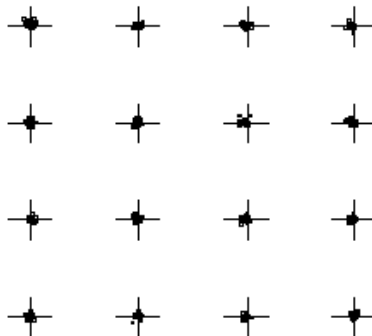

Figure 4-88 With Equalization



What is Adaptive Equalization?

Equalization is the process of applying a filter to a signal to remove or compensate for the effects of linear distortion. This filter can be defined in the frequency domain by frequency response parameters such as gain and phase or group delay. Alternatively it can be defined in the time domain by its impulse response.

Adaptive equalization dynamically creates and applies such a

compensating filter, modifying it to more completely compensate for distortion or to track changing signal characteristics.

Equalization is effective at compensating for linear distortion mechanisms including:

- Frequency response errors such as ripple or tilt
- Non-flat group delay or nonlinear phase
- Multipath or delay spread

However equalization is not effective on nonlinear distortion mechanisms such as:

- Noise
- Spectral regrowth or adjacent ch. interference
- Intermodulation
- Spurious
- Harmonic distortion

This lack of effectiveness on nonlinear distortion mechanisms is an unfortunate fact from the standpoint of receiver performance. However if the equalizer capability can be made switchable in the measuring receiver (test equipment), the result is an effective method to distinguish linear from nonlinear distortion. This has considerable implications in the testing of modulators, transmitters and transmission paths. These implications will be covered later in this paper.

Phase and Frequency Errors

For constant-amplitude modulation formats, such as GMSK used in GSM systems, the I/Q phase and frequency errors are more representative measures of the quality of the signal than EVM. As with EVM, the analyzer samples the transmitter output in order to capture the actual phase trajectory. This is then demodulated, and the ideal (or reference) phase trajectory is mathematically derived. Comparing the actual and reference signals determine the phase error. The mean gradient of the phase error signal is the frequency error.

Significant phase errors can indicate problems in the baseband section of the transmitter. The output amplifier in the transmitter can also create distortion that causes unacceptably high phase error for multi carrier signals. Significant phase error at the beginning of a burst can indicate that a synthesizer is failing to settle quickly enough. In a real system, poor phase error reduces the ability of a receiver to correctly demodulate, especially with marginal signal conditions. This ultimately degrades sensitivity.

Frequency error is the difference between the specified carrier frequency and the actual carrier frequency. A stable frequency error simply indicates that a slightly wrong carrier frequency is being used. Unstable frequency errors can indicate short-term instability in the LO, improper filtering, AM-PM conversion in the amplifier, or wrong

modulation index if the transmitter is implemented using an analog frequency modulator. See “References” on page 308 for more information on phase and frequency error and other GSM measurements.

Frequency Response

As noted above, equalization compensates for certain signal imperfections in the transmitter, transmission path or receiver. Equalization removes only linear distortion. Linear distortion occurs when the signal passes through one or more linear devices having transfer functions containing amplitude unflatness (for example, ripple and tilt), and/or group delay variations over the bandwidth of the signal. There can be many sources of linear distortion in a system: bandpass filters in the IF, improper cable terminations, improper baseband filtering, non-compensated $\sin(x)/x$, antenna mismatch, signal combiners and multipath signal effects. From a modeling standpoint, all of the linear distortion mechanisms can be combined and represented by a single transfer function, $H(f)$.

When applying equalization, the measuring instrument must counteract the effects of the linear distortion. To achieve that, an equalizer filter whose transfer function is $1/H(f)$ is applied over the bandwidth of the signal.

Once equalization has been applied, the inverse transfer function of the equalizer, which represents the linear distortion elements of the device under test, can be displayed and measured. If measured directly at the transmitter’s output, the inverse transfer function is basically the bits-to-RF frequency response 1 of the transmitter (or the variations from the ideal frequency response caused by non-linear distortions). See “References” on page 308. The actual frequency response can be displayed and measured as magnitude and phase. Ideally, the magnitude of the frequency response should be flat across the frequency band of interest, and its phase should be linear over that same frequency band.

Figure 4-89

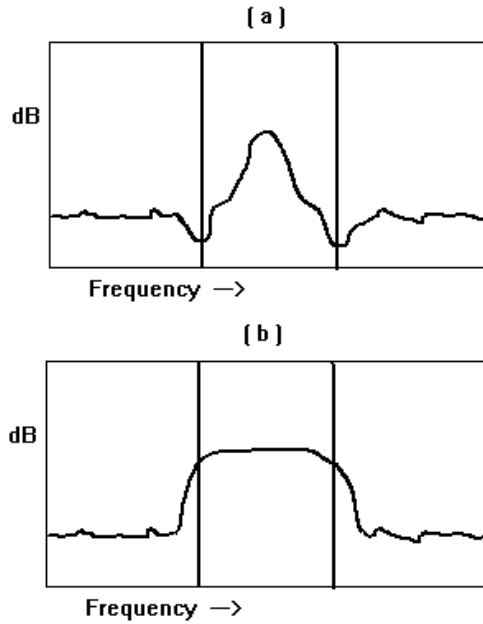

Rho

CDMA systems use ρ (rho) as one of the modulation quality metrics. ρ is measured on signals with a single code channel. It is the ratio of correlated power to total power transmitted [Figure 4-90](#). The correlated power is computed by removing frequency, phase and time offsets, and performing a cross correlation between the corrected measured signal and the ideal reference. If some of the transmitted energy does not correlate, this excess power appears as added noise that may interfere with other users on the system.

Figure 4-90

Rho

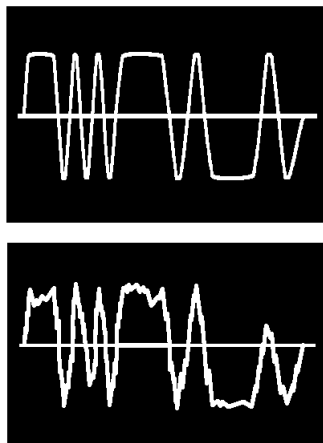

The rho measurement indicates the overall modulation performance

level of a CDMA transmitter when transmitting a single channel. Since uncorrelated power appears as interference, poor rho performance affects the capacity of the cell. See “References” on page 308.

Digital Modulation Errors and Signal Impairments

Recall first the basics of vector modulation: digital bits are transferred onto an RF carrier by varying the carrier’s magnitude and phase. At each symbol-clock transition, the carrier occupies any one of several unique locations on the I versus Q plane. Each location encodes a specific data symbol, which consists of one or more data bits. A constellation diagram shows the valid locations (i.e., the magnitude and phase relative to the carrier) for all permitted symbols of which there must be 2^n , given n bits transmitted per symbol. To demodulate the incoming data, the exact magnitude and phase of the received signal for each clock transition must be accurately determined.

Looking at the I/Q waveform in the time domain, the signal trajectory would look similar to Figure 4-91. The symbol is delivered at the decision point, a small slot in time when the receiver records the I and Q voltages. The digital receiver must know when to read the symbol. The receiver recovering the symbol rate from the signal itself, creating the symbol clock, accomplishes this. This process is called clock recovery.

Figure 4-91 Decision Points

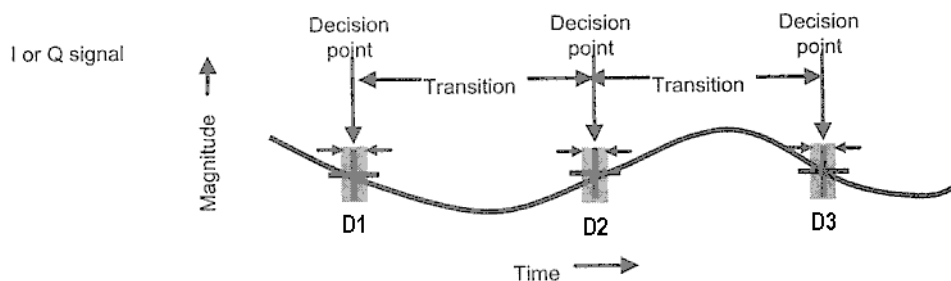

The layout of the constellation diagram and its ideal symbol locations is determined generically by the modulation format chosen (BPSK, 16QAM, $\pi/4$ DQPSK, etc.). The trajectory taken by the signal from one symbol location to another is a function of the specific system implementation, but is readily calculated nonetheless. The trajectories between constellation symbol points are best seen in the I/Q or Eye diagram.

Relationship Between I/Q, Constellation and Eye Diagrams

Figure 4-92 shows three decision points in the time domain D1, D2 and D3. Each decision point appears as an I/Q plane for the QPSK format (four symbols). In the QPSK format, the signal trajectories between decision points are not restricted. The trajectory between D1, D2 and D3 vary with the I/Q voltages, similar to those shown in Figure 4-92. The accuracy of the I/Q voltages determines how closely signal passes its symbol on any I/Q plane (decision point). The ideal point is usually indicated by a cross-hair cursor. If the modulation is high quality, the vector should go through one of the symbol point cross hairs.

From the Z-axis in Figure 4-92 the vector path looks as seen in I/Q or Constellation diagrams as shown in Figure 4-93.

An observer standing on the I or Q axis looking at the three decision points would observe an Eye diagram, if each trajectory were to persist after the signal had gone. An accumulated record of all the trajectories between these three decision points would appear like Figure 4-94.

Figure 4-92

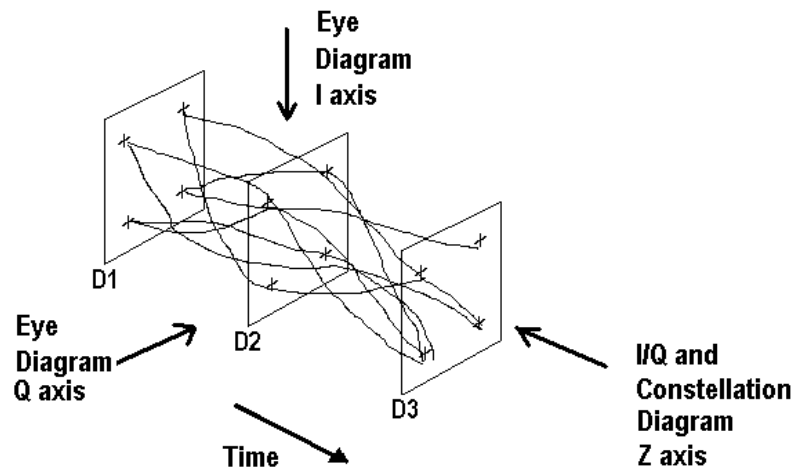

I/Q and Constellation Diagrams

The vector diagram, more commonly called an I/Q diagram in digital modulation, shows the recovered complex, I/Q baseband signal at all moments in time. It shows the states and transitions between them as the signal moves from symbol to symbol in time. A vector drawn from the origin to a point on the vector diagram corresponds to the instantaneous power at that instant in time

Figure 4-93 (a) shows an example I/Q diagram for the “QPSK” modulated signal mentioned earlier. The I/Q diagram shows the 4 ideal

state locations (indicated by the crosshairs) positioned at 45, 135, -45, and -135 degrees, the detected symbols, and the transitions between the symbols. The I/Q diagram gives you the peak-to-average power ratios and can be used to determine amplifier compression among other things

Figure 4-93

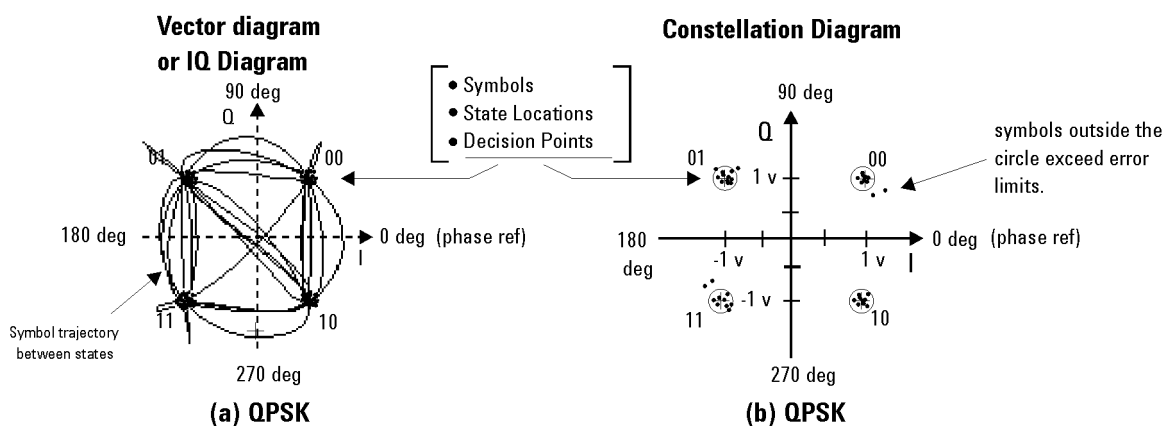

(a) The Vector or IQ diagram shows the detected symbols and the transitions between them. (b) shows the instantaneous power levels during state transitions. (b) The Constellation diagram shows the detected symbols versus ideal states, giving you a visual indication of the quality of the measured signal.

Interpreting I/Q Diagrams

When viewing signals in the I/Q plane, keep in mind that you are looking at the signal's amplitude and phase relative to the carrier. The unmodulated carrier is the phase reference (0 deg.). In Figure 4-93(a), each of the detected symbols modulate the carrier at differing amplitudes and phases relative to the unmodulated carrier, but at the same frequency as the carrier. If the detected symbols were at different frequencies than the unmodulated carrier, they would appear to move as they continuously gain or lose phase relative to the unmodulated carrier. Also, digital modulation is a 3-dimensional measurement, modulation in terms of its I (In-Phase) and Q (Quadrature) components versus time. The I/Q diagram is only a 2-dimensional display, so the time parameter, which cannot be seen, is perpendicular to the I/Q plane (or display screen).

Constellation Diagram

Figure 4-93(b) shows the constellation diagram for the same QPSK signal. The constellation diagram shows the carrier's magnitude and phase synchronous with the symbol clock. The measurement points are commonly referred to as detection decision-points and represent the detected symbols. It is similar to the I/Q diagram, without showing the transition traces between states.

Ideally all symbols should appear as a single point centered at the ideal state location (indicated by the crosshairs). The ideal state is where symbols occur if your signal is without error. However, signal impairments and other modulation errors cause deviations and the symbols will disperse and surround the ideal state location. The PSA allows you to put definable error-limit circles around the ideal states. Showing the actual detected symbols versus the ideal states, gives you a visual indication of the quality of your signal. Constellation diagrams help identify such signal impairments as amplitude imbalance, quadrature error, or phase noise.

Eye diagrams

Figure 4-94 shows another method to view a digitally modulated signal, with an eye diagram. Separate eye diagrams can be generated, one for the I-channel data and another for the Q-channel data. Eye diagrams display I and Q magnitude versus time in an infinite persistence mode, with retraces. The I and Q transitions are shown separately and an “eye” (or eyes) is formed at the symbol decision times. QPSK has four distinct I/Q states, one in each quadrant. There are only two levels for I and two levels for Q. This forms a single eye for each I and Q. Other schemes use more levels and create more nodes in time, through which the traces pass. The lower example is a 16QAM signal which has four levels forming three distinct “eyes.” The eye is open at each symbol. A “good” signal has wide open eyes with compact crossover points.

Figure 4-94

Eye diagram

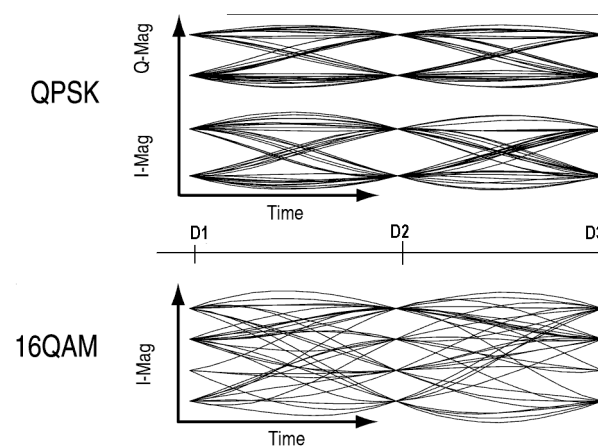

Impairments

How can you verify the different I/Q impairments? The best method to verify most I/Q impairments is to look at the constellation and EVM metrics.

Matching problems due to component differences between the I side and Q side of a network can cause I/Q impairments. The I/Q modulator

in the transmitter is a significant source of I/Q impairments. A diagram of it is shown in Figure 4-95.

For any of these errors, magnifying the scale of the constellation can help detect subtle imbalances visually. Since the constellation is affected, these errors deteriorate EVM.

The most common I/Q impairments are listed below:

Figure 4-95 I/Q Modulator a source of Impairments

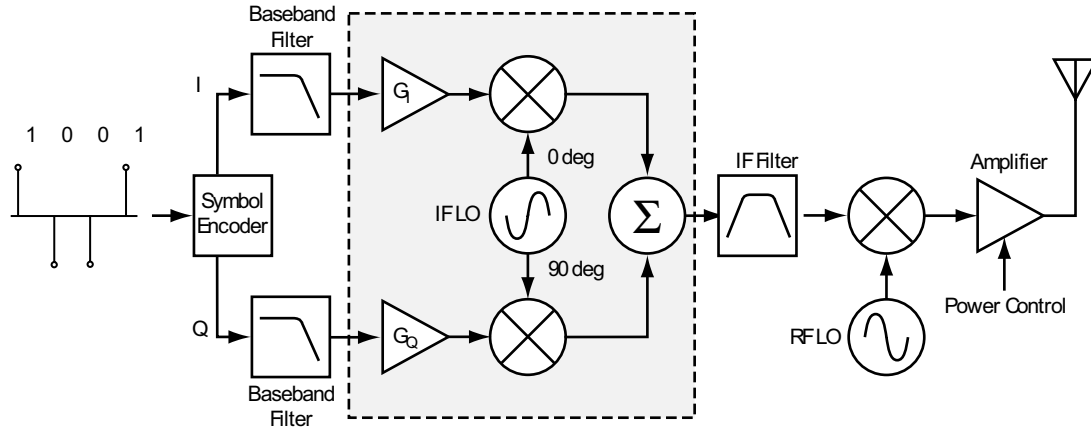

I/Q Gain Imbalance

Since I and Q are two separate signals, each one is created and amplified independently. Inequality of this gain between the I and Q paths results in incorrect positioning of each symbol in the constellation, causing errors in recovering the data. I/Q gain imbalance results in an asymmetric constellation, as seen in Figure 4-96. This problem is rare in systems where the IF is implemented digitally.

Figure 4-96 I/Q Gain Imbalance

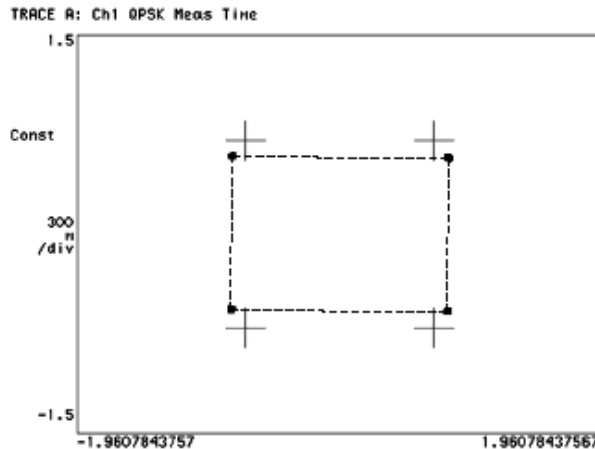

Quadrature errors

Quadrature errors. If the phase shift between the IF (or RF) LO signals that mix with the I and Q baseband signal at the modulator is not 90 degrees, a quadrature error occurs. The constellation of the signal is distorted (see [Figure 4-97 on page 297](#)), which may cause error in the interpretation of the recovered symbols.

Quadrature errors result in a “tipped” or skewed constellation, as seen in [Figure 4-97](#)

Figure 4-97

I/Q Quadrature Errors

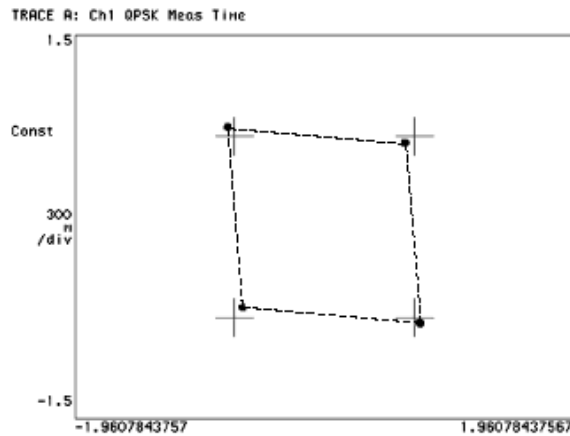

I/Q Offsets

DC offsets may be introduced in the I and Q paths. They may be added in by the amplifiers in the I and Q paths, see [Figure 4-98](#).

For digital IF implementations, offsets may also occur from rounding errors in the DSP. I/Q offsets result in carrier feed through. Some instruments compensate for this error before displaying the constellation or polar diagram and measuring EVM. In that case, I/Q offset is given as a separate error metric.

Figure 4-98

Ideal Versus I/Q Offset Constellation

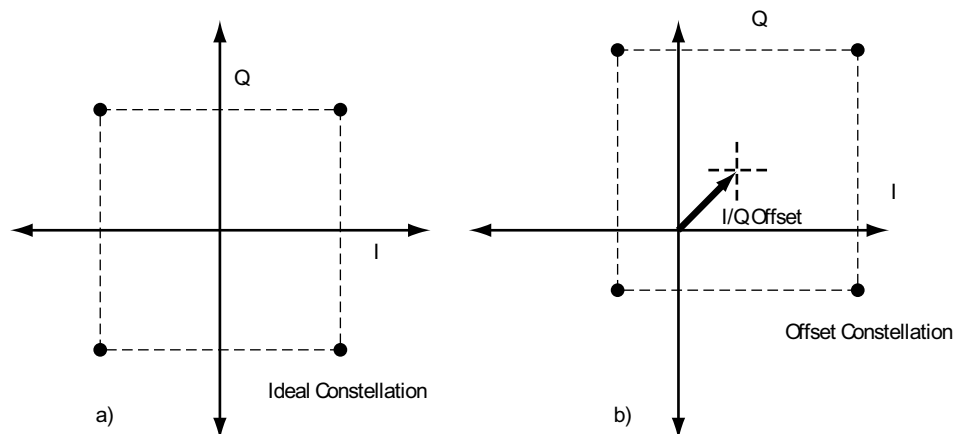

Delays in I/Q paths

Delays in the I or Q paths also distort the measured constellation.

When the serial bit stream is encoded into symbols and the bits are split into parallel paths for creation of the I and Q signals, it is important that these signals are properly aligned. Problems in this process can cause unwanted delays between the I and Q signals. Delays can be caused by the modulator or by the previous components in the I or Q paths (for example, the baseband filter or the DAC). For instance, if the baseband filters are analog, variations in group delay between the filters cause different delays in the I and Q paths. Different electrical lengths in the I and Q paths may also cause significant delay differences between the two paths, especially for signals with wide bandwidths (high symbol rates). See [Figure 4-99](#).

However, if the delay is an integer number of samples, the final encoded symbols transmitted appear positioned correctly but are incorrect. The error cannot be detected unless a known sequence is measured. Mathematical functions in the measuring instrument can help compensate for delays between I and Q, by allowing you to introduce delays in the I or Q paths. In this way, you can confirm and measure the delay.

Figure 4-99 Delays in I/Q paths

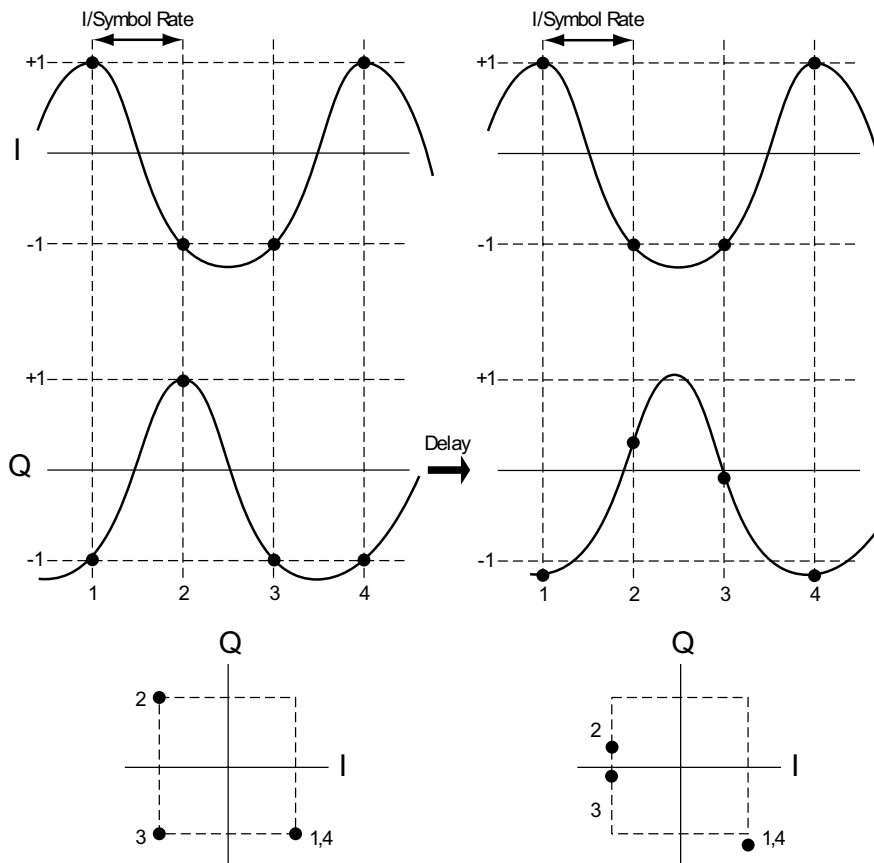

I/Q Signals “Swapped”

“Swapping”, or accidentally exchanging, the I and Q signals reverses the phase trajectory and inverts the spectrum around the carrier. Therefore, swapping the I and Q or changing the sign of the shift (+90 or -90 degrees) makes a difference in the signal transmitted: $\cos(\omega_{LO} t) - j\sin(\omega_{LO} t)$ versus $\cos(\omega_{LO} t) + j\sin(\omega_{LO} t)$. The mapping of the IF I and Q signals is reversed, which causes symbol errors, as seen in [Figure 4-100](#)

Figure 4-100

I/Q Signals “Swapped”

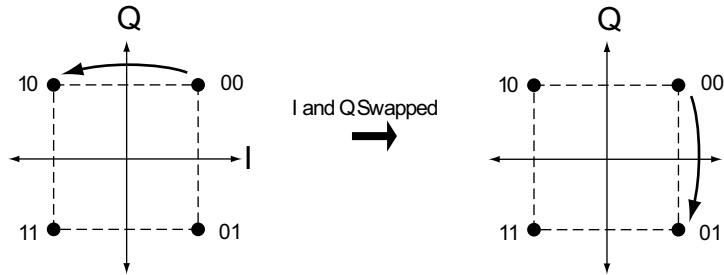

The condition I/Q swapped, results in an inverted spectrum. However, because of the noise-like shape of digitally modulated signals, the inversion is usually undetectable in the frequency domain.

Digital Modulation Displays

NOTE All the examples in the following section are all views of a single NADC signal measurement, except the FSK Error (Quad-View), which is an APCO25 phase1 (FSK) signal. Upon completion of the measurement, the views were selected by pressing **View/Trace**, and selecting the view.

Figure 4-101 I/Q Measured Polar Vector diagram

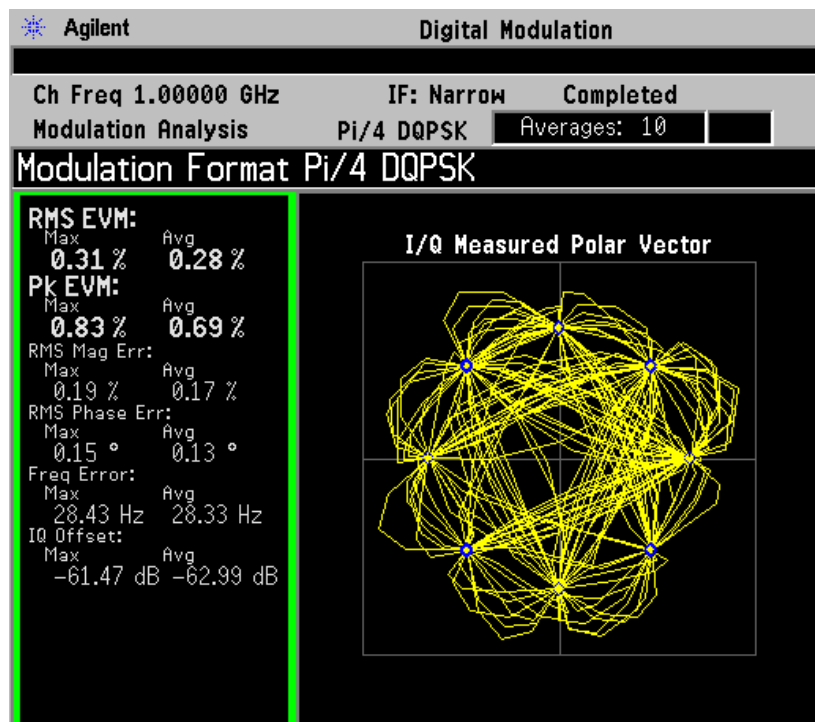

Figure 4-101 shows the “I/Q Measured Polar Graph view”. Individual displays of a large “I/Q Measured Polar Graph” and a summary of the “Numeric Results”.

- A good place to start viewing demodulation results is the I/Q Measured Polar Vector diagram. This tool shows the complex recovered signal at all moments in time with the symbol clock marked with blue dots. The practiced viewing of the vector diagram can see proper modulation format, filtering and other qualitative aspects of the signal.
- The Numeric Results summary shows many important measurement parameters. For a more comprehensive list select the Numeric Results view.

Figure 4-102 shows the “I/Q Error (Quad View)”. Individual displays of “I/Q Mag Error”, “I/Q Phase Error”, “EVM” and a summary of “Numeric Results”. These are modulation quality measurements that were defined in.

When modulation errors are observed from the I/Q Measured Polar

diagram, the next step might be to determine what is the nature of these errors. EVM can be broken down into its magnitude and phase components.

Figure 4-102 I/Q Error (Quad View)

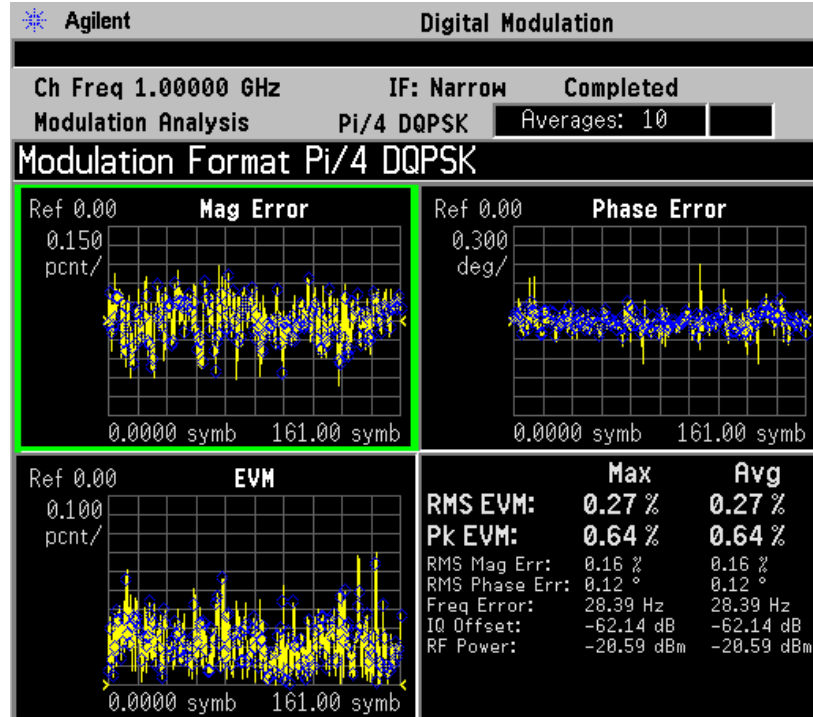

- The “I/Q Mag Error” and “I/Q Phase Error” windows show the error between the I/Q measured and the I/Q reference signals. I/Q Mag Error displays the magnitude error and I/Q Phase Error displays the phase error.
- The EVM vs time windows show the difference between the input signal and the internally generated reference.
- The Numeric Results summary shows many important measurement parameters. For a more comprehensive list select the Numeric Results view.

NOTE

The I/Q Error (Quad View) is the only view that supports markers.

Figure 4-103 Eye (Quad-View)

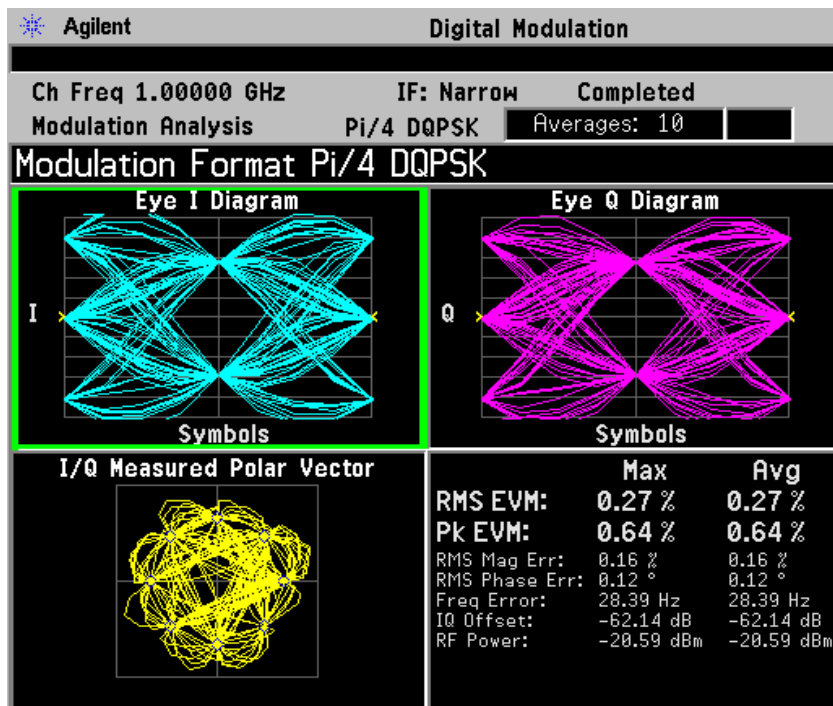

Figure 4-103 shows the “Eye (Quad View)”. Individual displays of “Eye I diagram”, “Eye Q diagram” a small “I/Q Measured Polar Graph”, and a summary of “Numeric Results”.

- Eye diagrams are a traditionally tools observed by connecting an oscilloscope to the I/Q test points of a digital radio. Shown are the I and Q voltages versus time. These voltages are retraced every few symbols to show using a statistical method, the repeatability of the signal. The opening of the "eye" shape in the trace is a qualitative indication of noise on the signal. Inconsistencies can be observed when the Eye I and Eye Q diagrams are shown next to each other.
- The I/Q Measured Polar Vector diagram shows the complex recovered signal at all moments in time with the symbol clock marked with red dots. The practiced viewing of the vector diagram can see proper modulation format, filtering and other qualitative aspects of the signal.
- The Numeric Results summary shows many important measurement parameters. For a more comprehensive list select the Numeric Results view.

Figure 4-104 FSK Error (Quad-View)

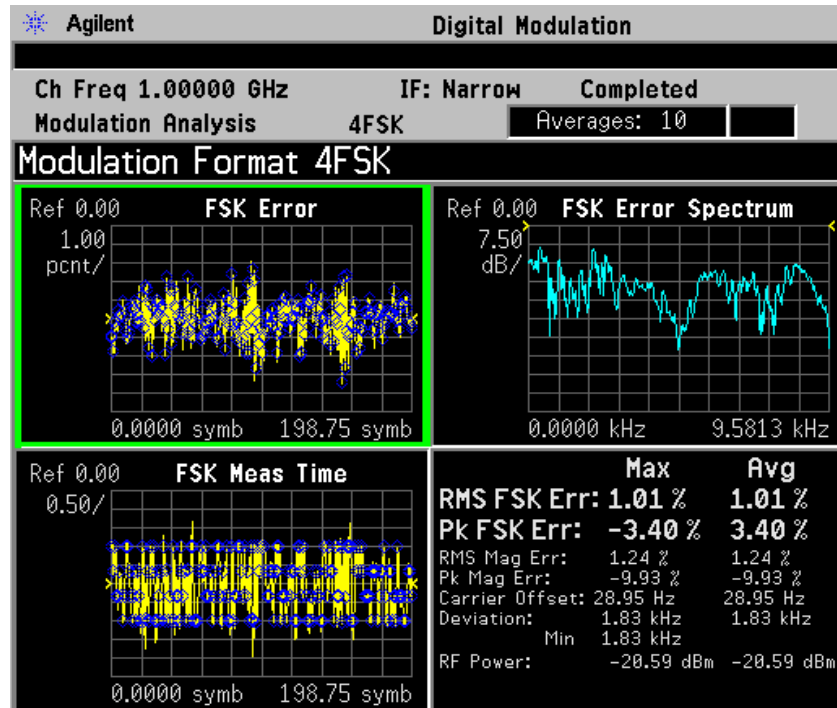

Figure 4-104 shows the “FSK Error”, “FSK Error Spectrum”, “FSK Meas Time”, and a summary of “Numeric Results”.

Numeric Results

The “Numeric Results” view is a powerful digital demodulation tool. For example, reviewing the rms EVM value can quickly help you assess modulation accuracy. Other valuable errors are also reported.

Figure 4-105

Numeric Results

Agilent		Digital Modulation	
Ch Freq	1.00000 GHz	IF: Narrow	Completed
Modulation Analysis	4FSK	Averages: 10	
Modulation Format 4FSK			
	Max	Avg	
RMS FSK Error	1.01 %	1.01 %	
Peak FSK Error	-3.40 % at sym 152	3.40 % at sym 152	
RMS Mag Error	1.24 %	1.24 %	
Peak Mag Error	-9.93 % at sym 93	-9.93 % at sym 93	
Carrier Offset	28.95 Hz	28.95 Hz	
Deviation	1.83 kHz	1.83 kHz	
	Min		
RF Power	-20.59 dBm	-20.59 dBm	

NOTE For more information on signal impairments, see the Making Measurements chapter.

Error Vector Spectrum (Quad-View)

The Error Vector Spectrum quad-view is a powerful digital demodulation tool. For example, the Error Vector Spectrum can help you to diagnose clock errors. Seeing the reference vector diagram can quickly help you assess modulation accuracy.

Figure 4-106

Error Vector Spectrum (Quad-View)

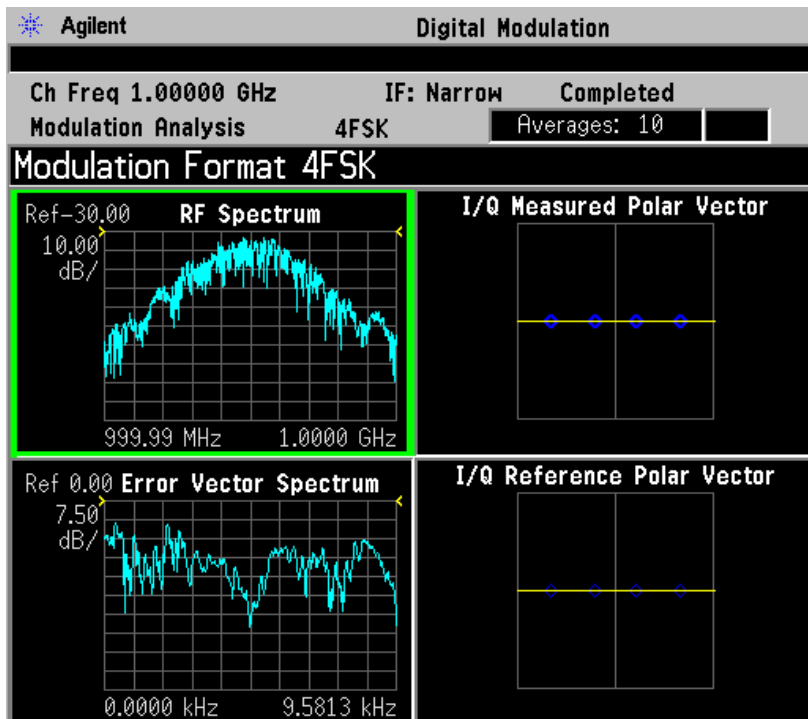

Concepts

Demod Bits

The Demod Bits view can help you assess modulation accuracy. The same EVM vs. Symbol display is shown, along with the demodulated bits. You may find a correlation between the bit errors and the EVM that indicates time-grouped errors or magnitude errors. You can select the EVM graph and use markers to explore the various data points.

Figure 4-107

Demod Bits View

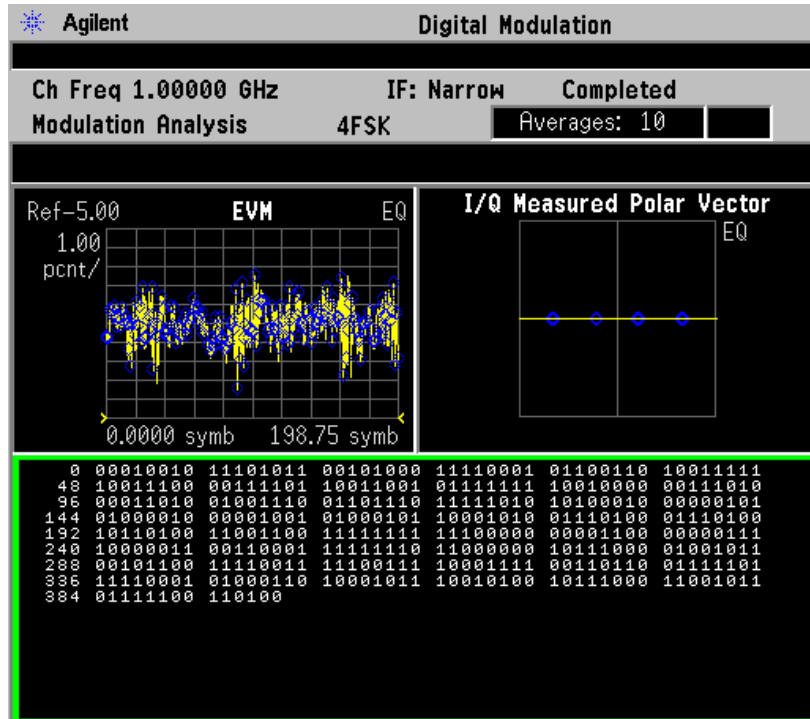

Equalizer (Quad-View)

Press **Trace/View, Equalizer (Quad View)**. The Eq Channel Response trace shows the frequency response channel for which the equalizer is correcting. Eq Channel Response is computed as the inverse of the equalization filter's frequency response. The data is complex and is normally displayed in units of magnitude and phase.

The Eq Impulse Response trace shows the impulse response of the equalization filter. The example shown in [Figure 4-108](#) is an EDGE signal.

The degree of equalization required to correct the measured signal is a direct indication of the linear distortion of the transmitter. For more information on equalization see [“Using Adaptive Equalization”](#) on page 56.

Figure 4-108 Equalizer (Quad-View) - EDGE Signal Example

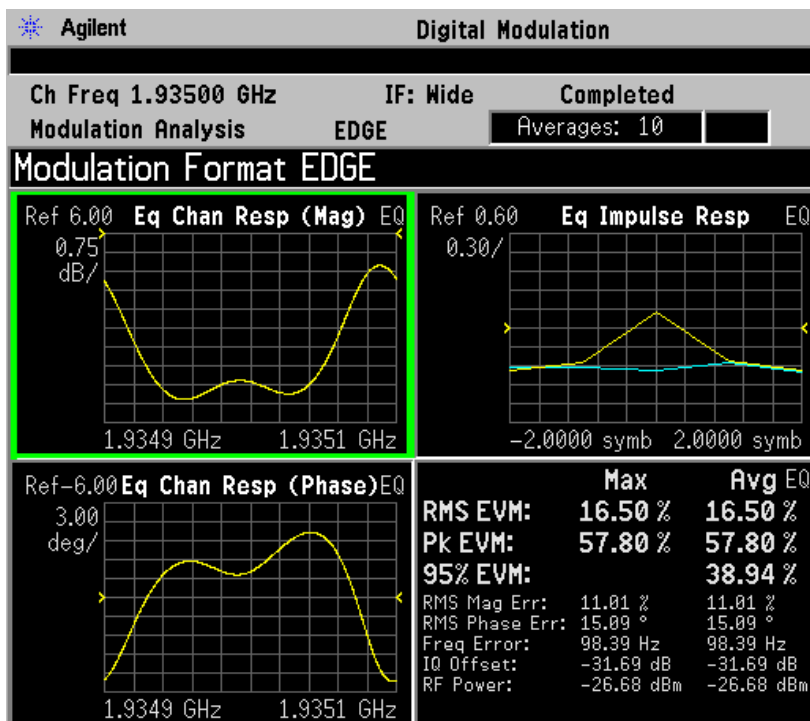

Concepts

References

- [1] Ken Thompson, "Concepts of cdma2000," Wireless Symposium, 999.
- [2] Designing and Testing W-CDMA Base Stations, Application Note 1355. Literature number 5980-1239E.
- [3] Understanding GSM Transmitter Measurements for Base Transceiver Stations and Mobile Stations, HP Application Note 1312, literature number 5968-2320E
- [4] Adaptive Equalization and Modulation Quality, Bob Cutler, Hewlett-Packard Wireless R&D Seminar, 1997.
- [5] Understanding CDMA Measurements for Base Stations and Their Components, HP Application Note 1311, literature number 5968-0953E

Other Sources of Digital Modulation Information

- Application Note 1298
Digital Modulation in Communications Systems - An Introduction
Agilent part number 5965-7160E
- Application Note 150
Spectrum Analysis
Agilent part number 35952-0292
- Application Note 1313
Test and Troubleshooting Digital RF Comm Transmitters
Agilent part number 5968-3578E
- Application Note 1314
Designing and Testing W-CDMA User Equipment
Agilent part number 5968-3579E
- Application Product Note 89400-14A
10 Steps to a Perfect Digital Demod Measurement
Agilent part number 75996-0444E
- Application Note 1311
Understanding CDMA Measurements for Base Stations and Their Components
Agilent part number 5968-0953E

5

Menu Maps

These menu maps are in alphabetical order by the front panel key label or oval cross-reference label. You can locate detailed information about each key/function at the page number listed in the figure title for each menu.

Flexible Digital Modulation Analysis Key Flow

The key flow diagrams, shown in a hierarchical manner on the following pages, will help grasp the overall functional relationships for the front-panel keys and the softkeys displayed at the extreme right side of the screen. The diagrams are:

- “Display Selection Key Flow” on page 312
- “Frequency Channel Key Flow” on page 313
- “Input / Output Key Flow” on page 314
- “Marker Selection Key Flow” on page 315
- “Measurement Selection Key Flow” on page 316
- “Measurement Setup 1 Key Flow” on page 317
- “Measurement Setup 2 Key Flow” on page 318
- “Measurement Setup 3 Key Flow” on page 319
- “Measurement Setup 4 Key Flow” on page 320
- “Measurement Setup 5 Key Flow” on page 321
- “Mode Selection Key Flow” on page 322
- “Mode Setup/Radio Channel Key Flow” on page 323
- “Trigger Key Flow” on page 324
- “Trace/View Selection Key Flow” on page 325
- “X Scale/ Y Scale Selection Key Flow” on page 326

Directions for Use

Refer to the following notes to utilize the key-flow diagrams:

- Start from the upper left corner of each measurement diagram. Go to the right, and go from the top to the bottom.
- When changing a key from auto (with underline) to manual, just press that key one time.
- When entering a numeric value for **frequency**, a value with units, use the numeric keypad and terminate the entry with the appropriate unit selection from the softkeys displayed.
- When entering a numeric value for a unitless value, like **Avg Number**, use the numeric keypad and terminate the entry with the **Enter** front-panel key.
- Instead of using the numeric keypad to enter a value, it may be easier to use the front-panel knob or **Up/Down** arrow keys.

Table 5-1 Menu Map Legend





Icon	Description
	This represents the analyzer front-panel key.
	An oval represents additional levels of menus.
	This box shows how the softkey default condition is displayed. Default parameters or values are underlined wherever possible.
	A dagger to the left of a softkey indicates that when the key is pressed this is an active function.
	A double-dagger to the left of the softkey indicates a function that is not always available. It is dependent on other instrument settings.
	A bar on the left of two or more softkeys indicates that the keys are a mutually exclusive choice.

Figure 5-1 Display Selection Key Flow

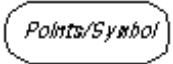
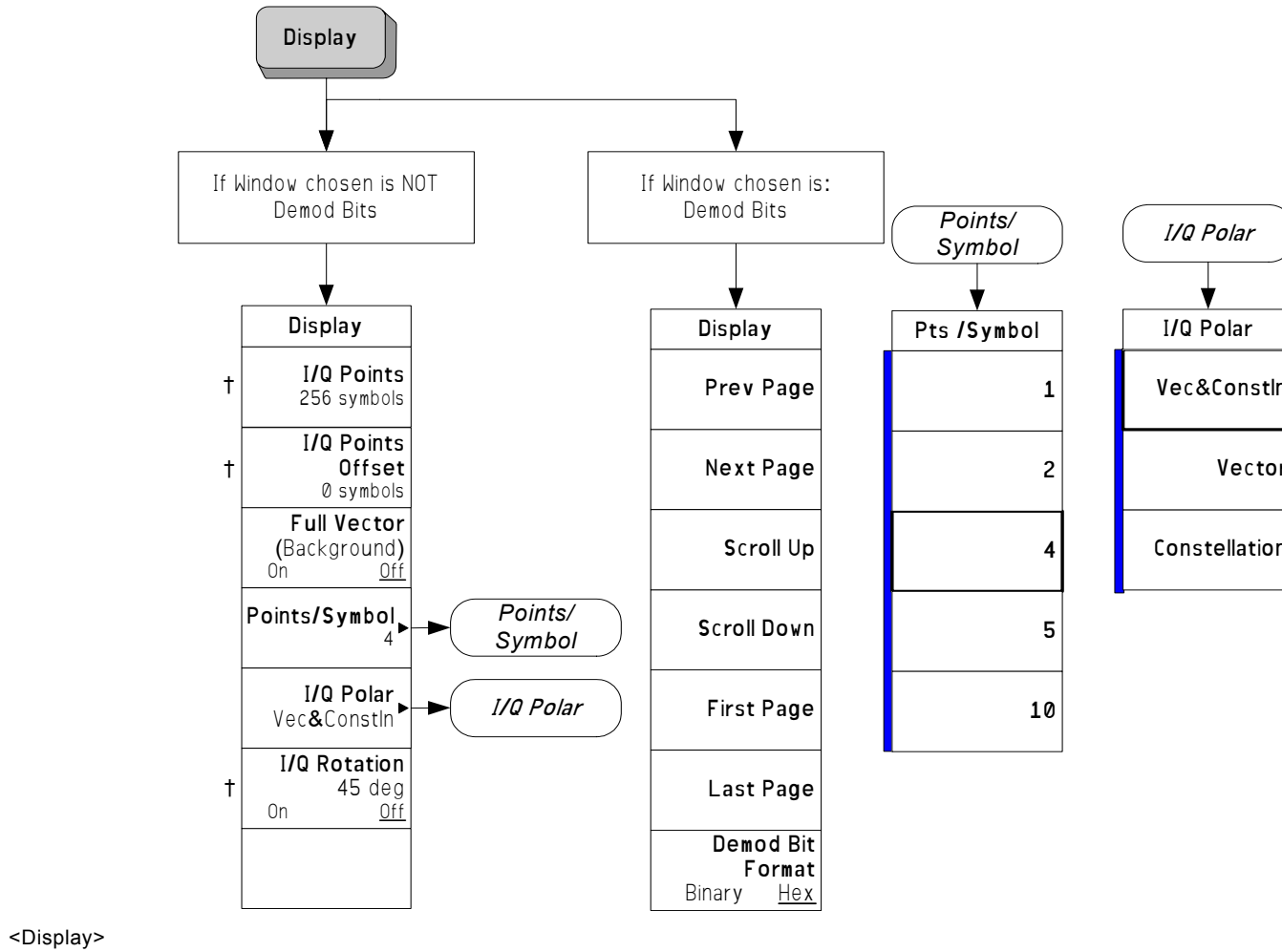

Figure 5-2 Frequency Channel Key Flow

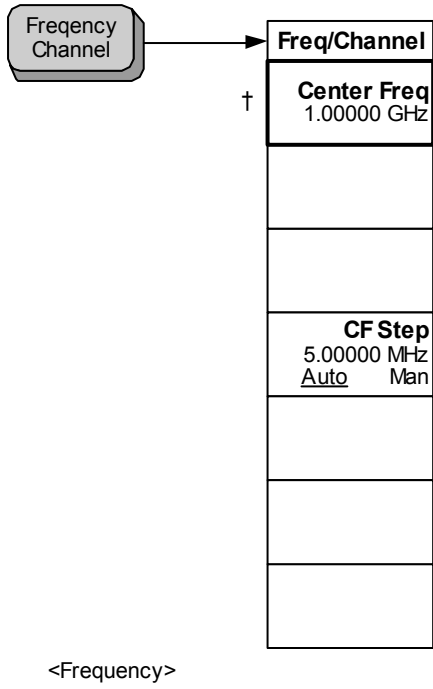

Figure 5-4 Marker Selection Key Flow

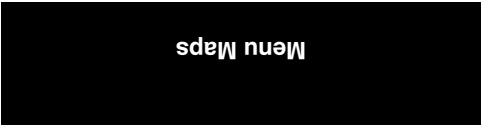
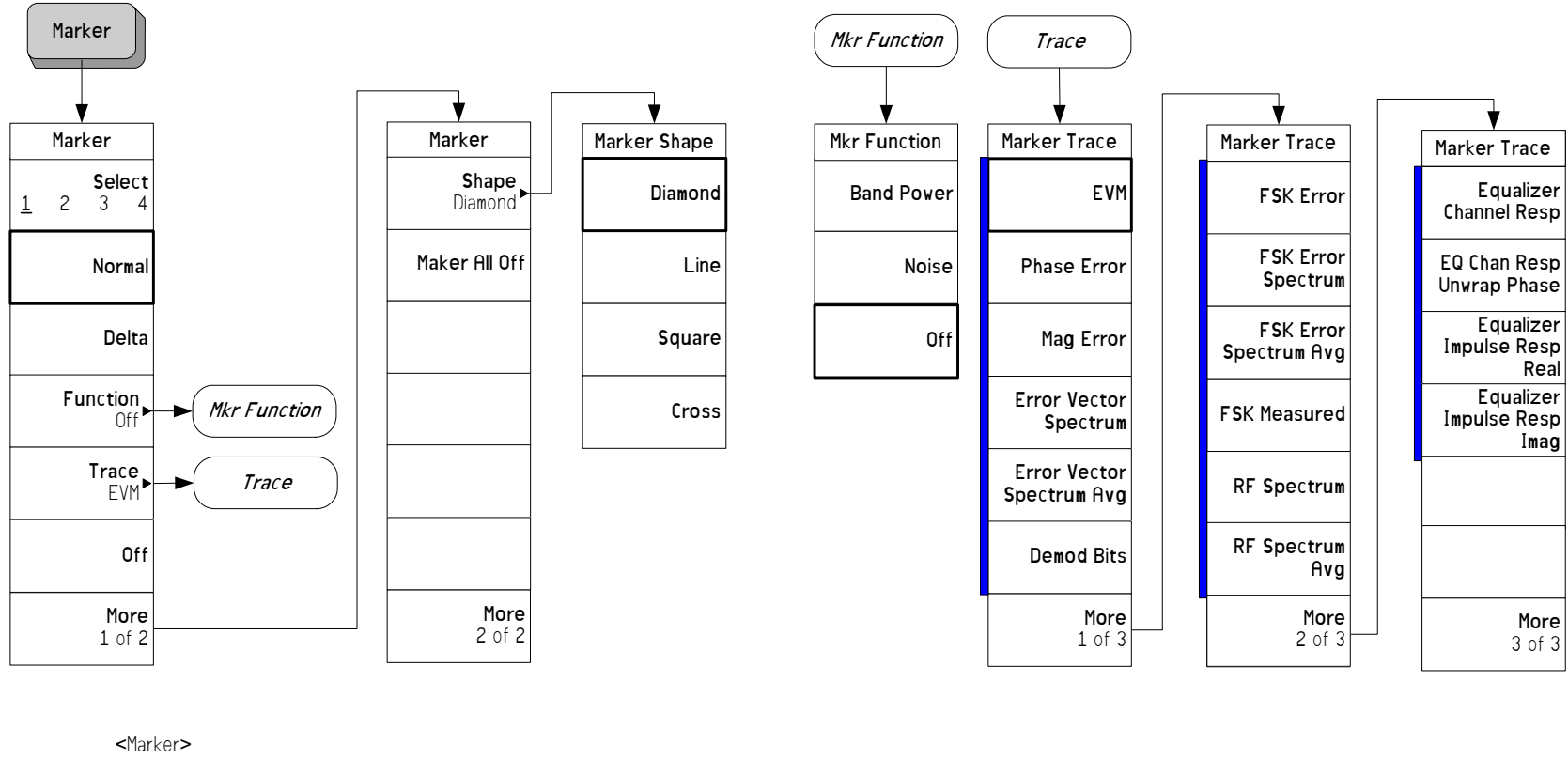
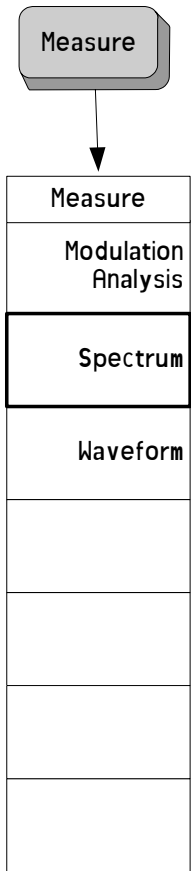

Figure 5-5 Measurement Selection Key Flow



<Measure>

Figure 5-6 Measurement Setup 1 Key Flow

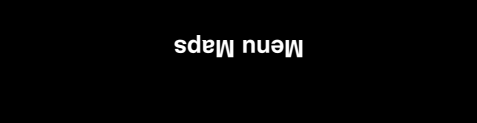
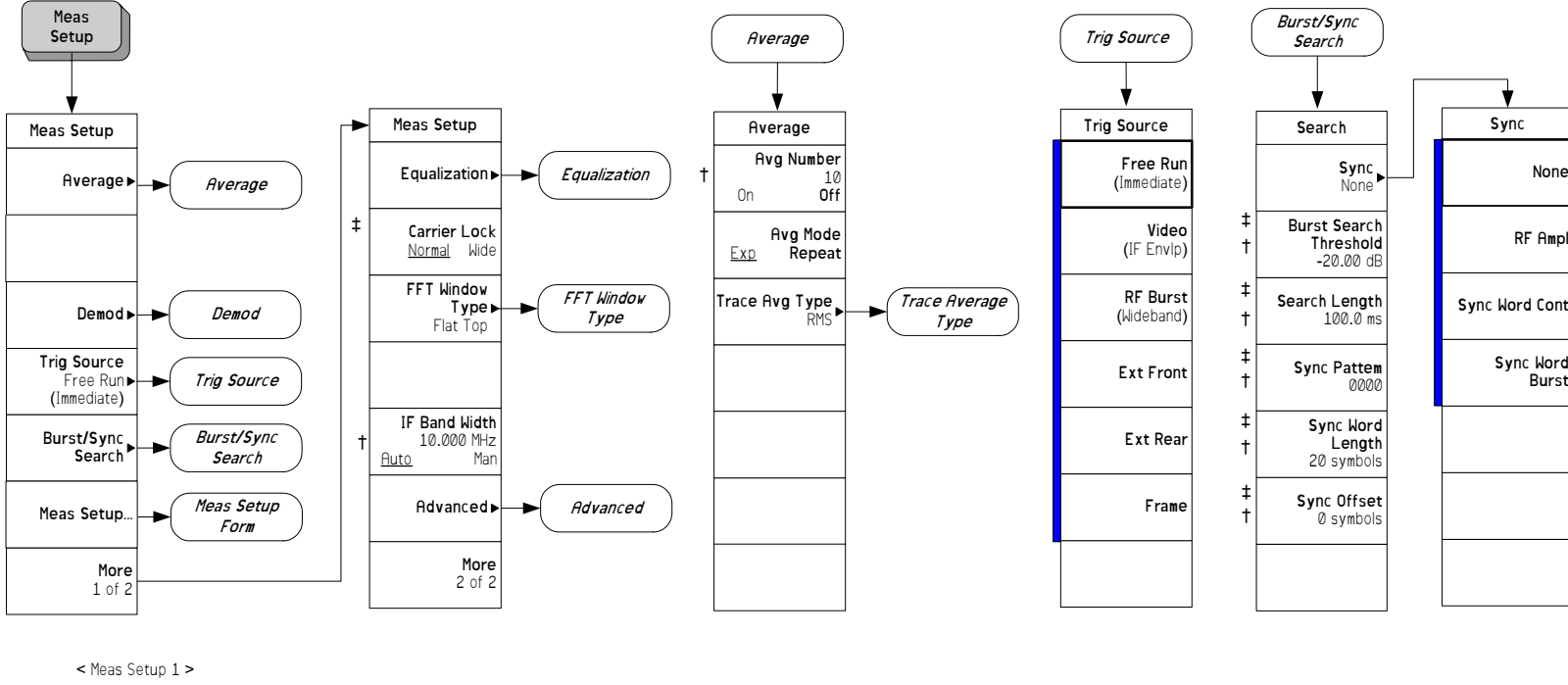
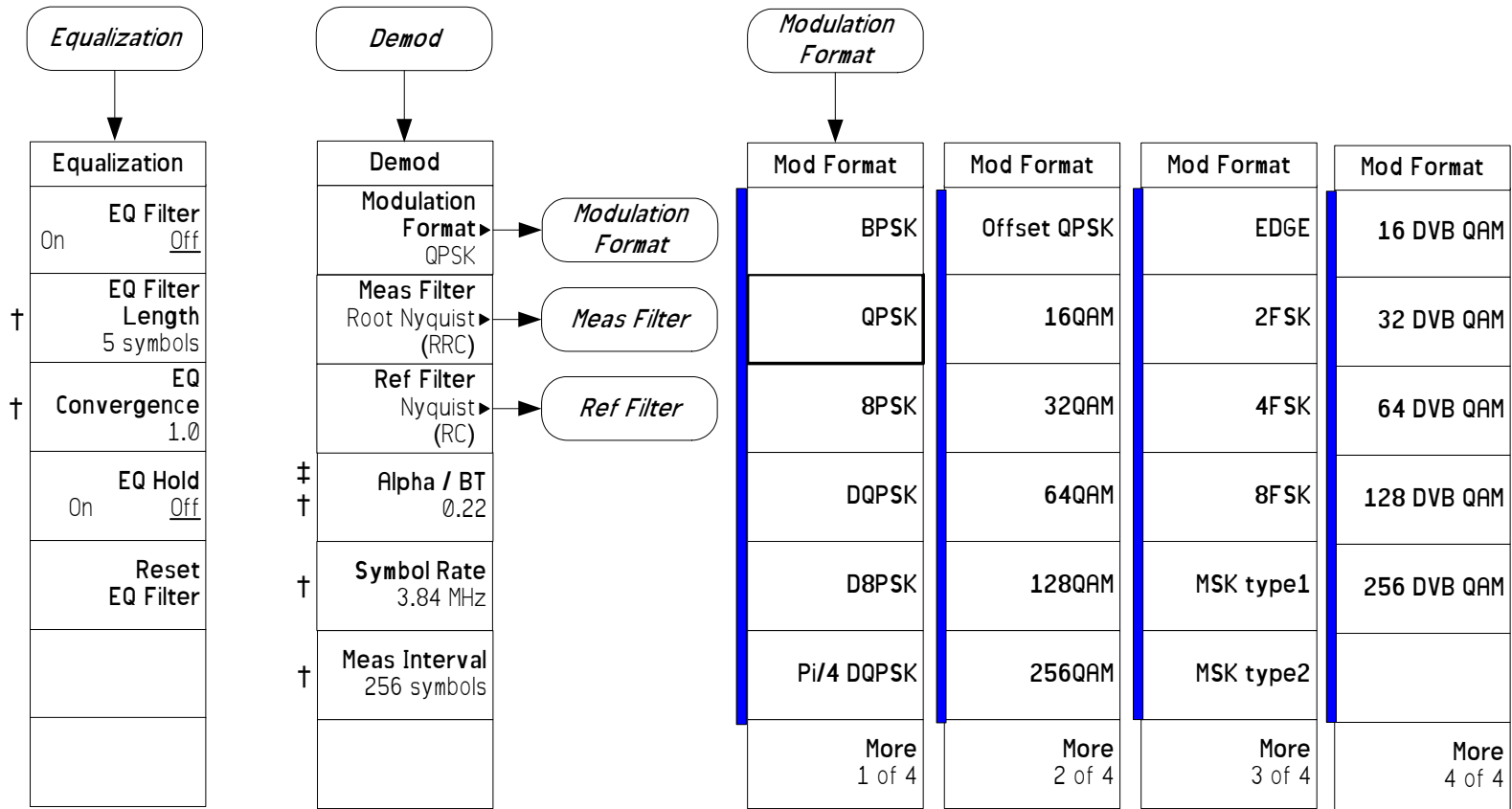
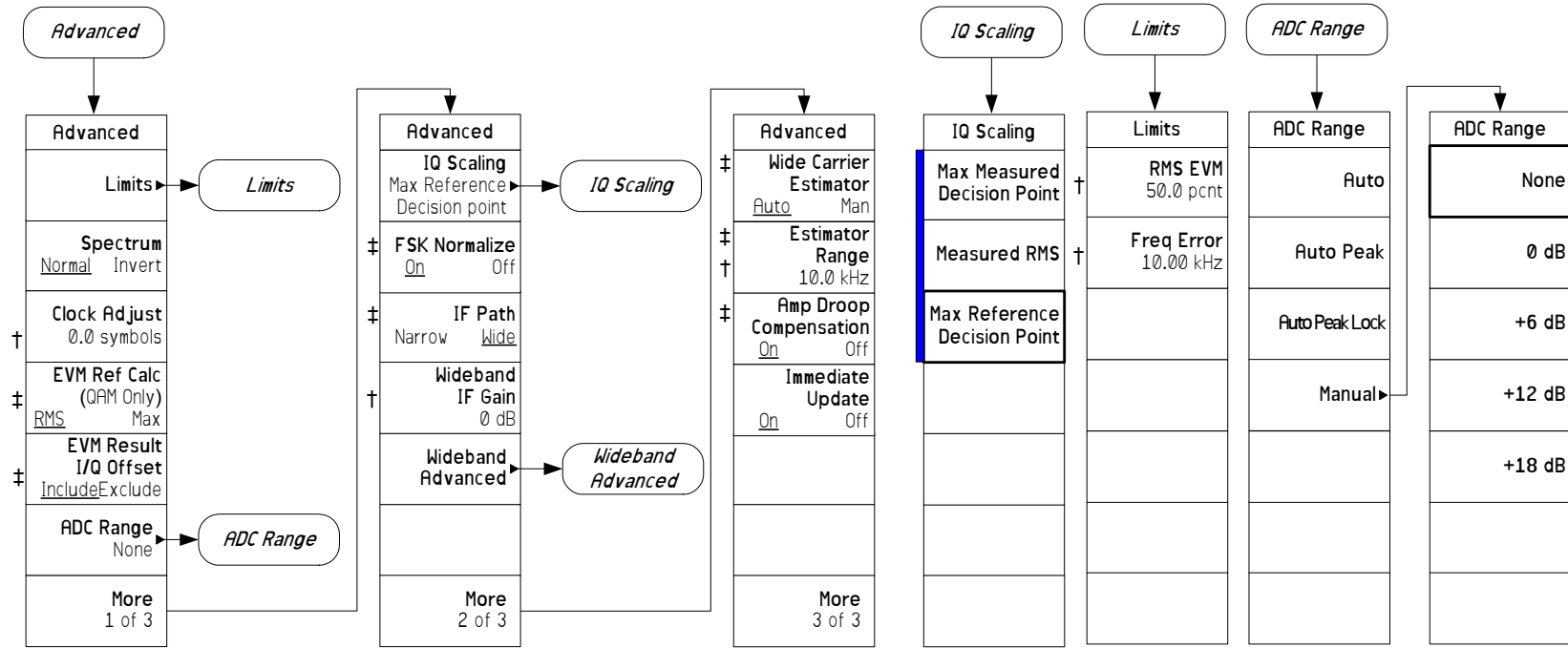

Figure 5-7 Measurement Setup 2 Key Flow



< Meas Setup 2 >

Figure 5-8 Measurement Setup 3 Key Flow



< Meas Setup 3 >

Figure 5-9 Measurement Setup 4 Key Flow

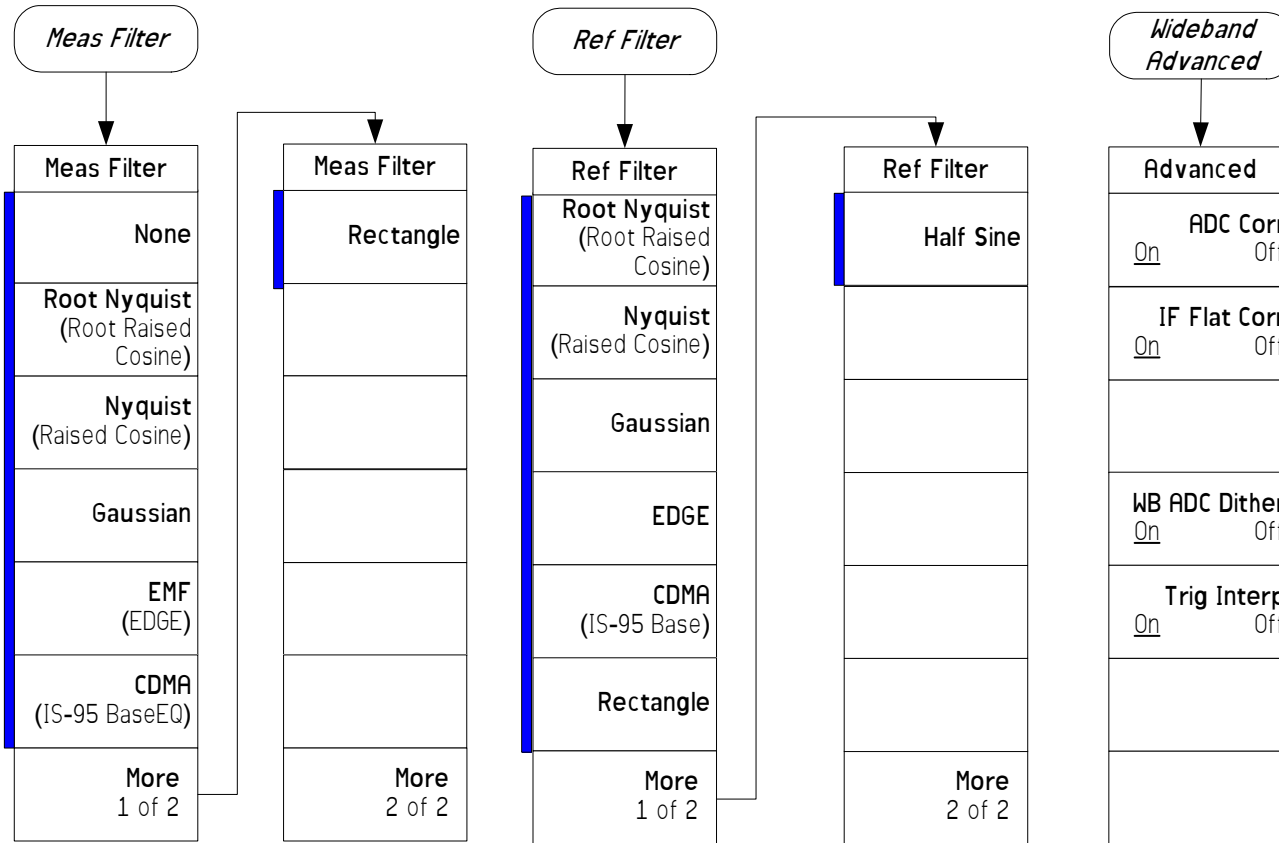

< Meas Setup 4 >

Figure 5-10 Measurement Setup 5 Key Flow

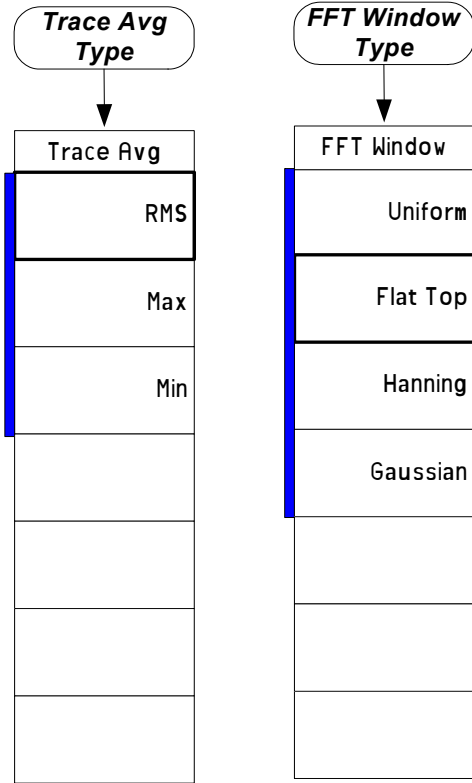

Figure 5-11 Mode Selection Key Flow

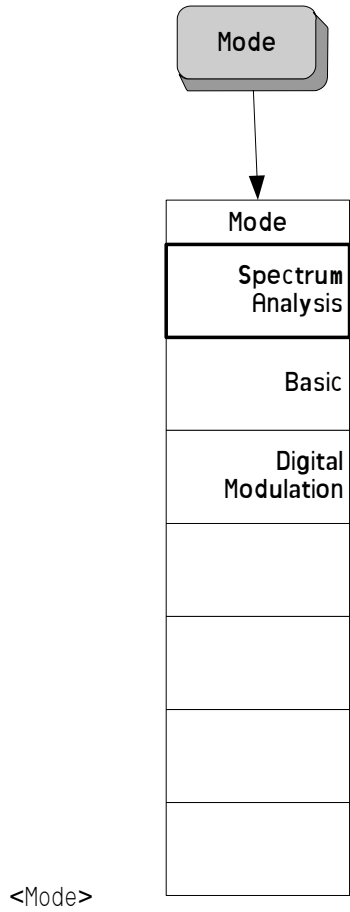

Figure 5-12 Mode Setup/Radio Channel Key Flow

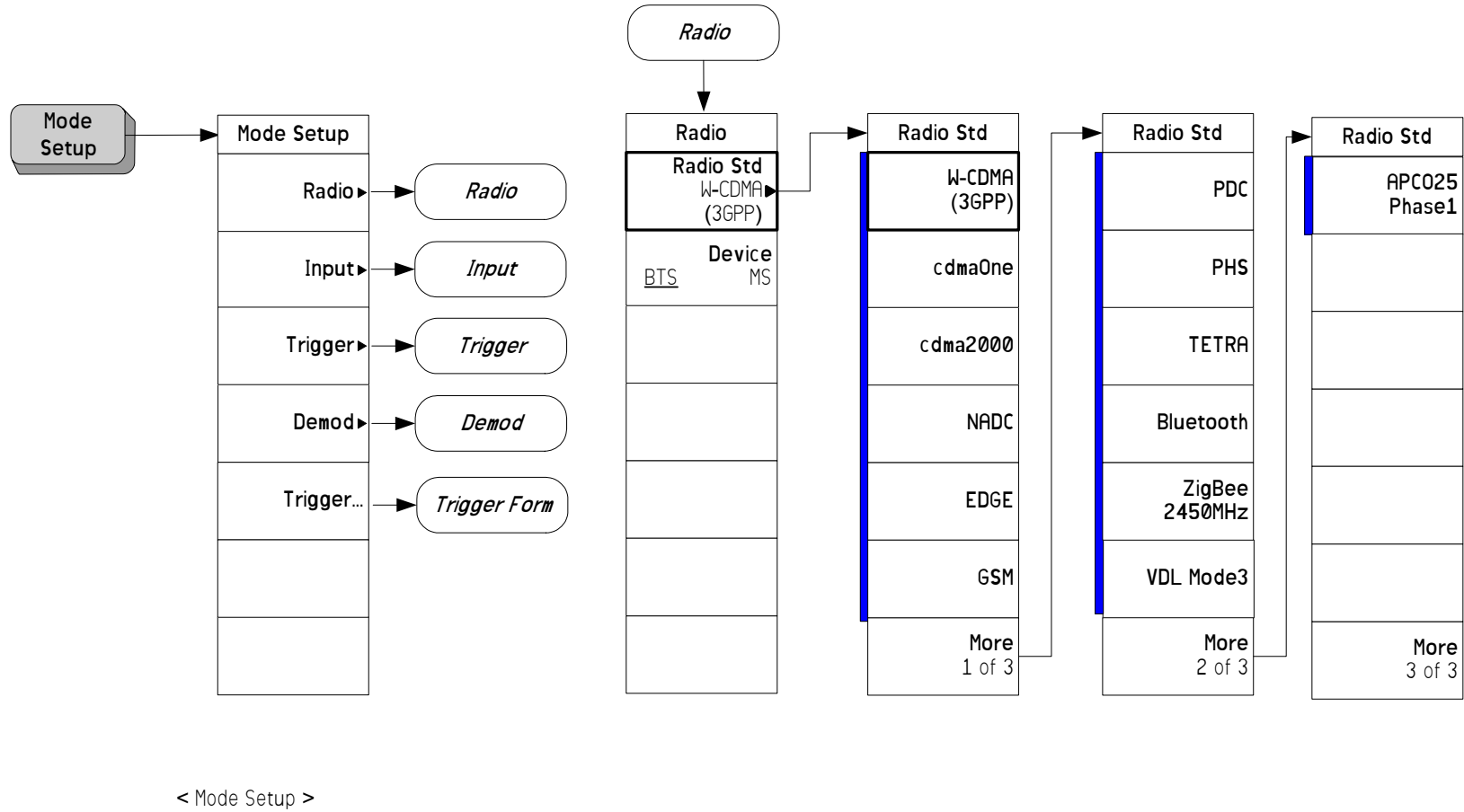
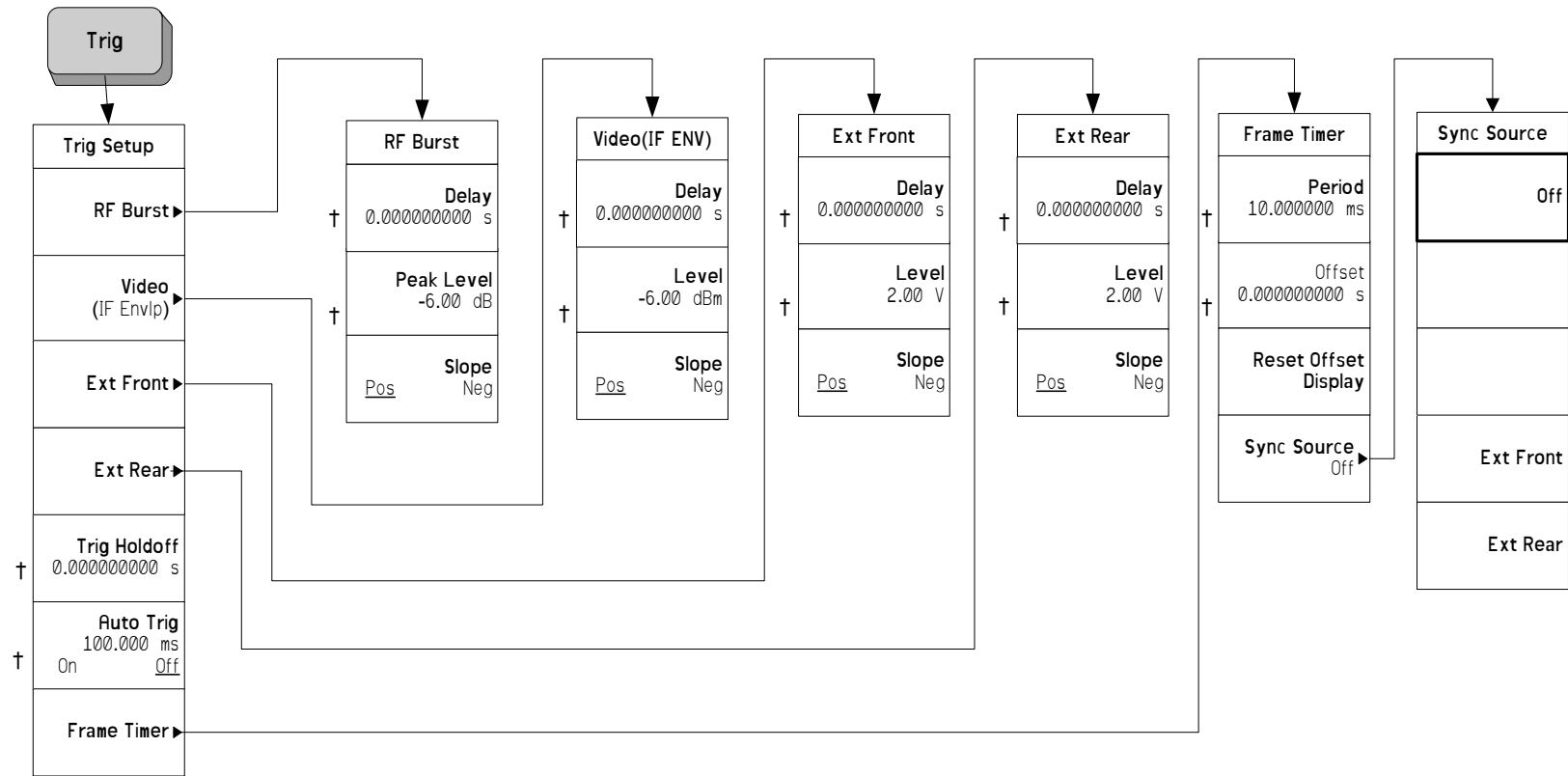

Figure 5-13 Trigger Key Flow



< Trigger >

Figure 5-14 Trace/View Selection Key Flow

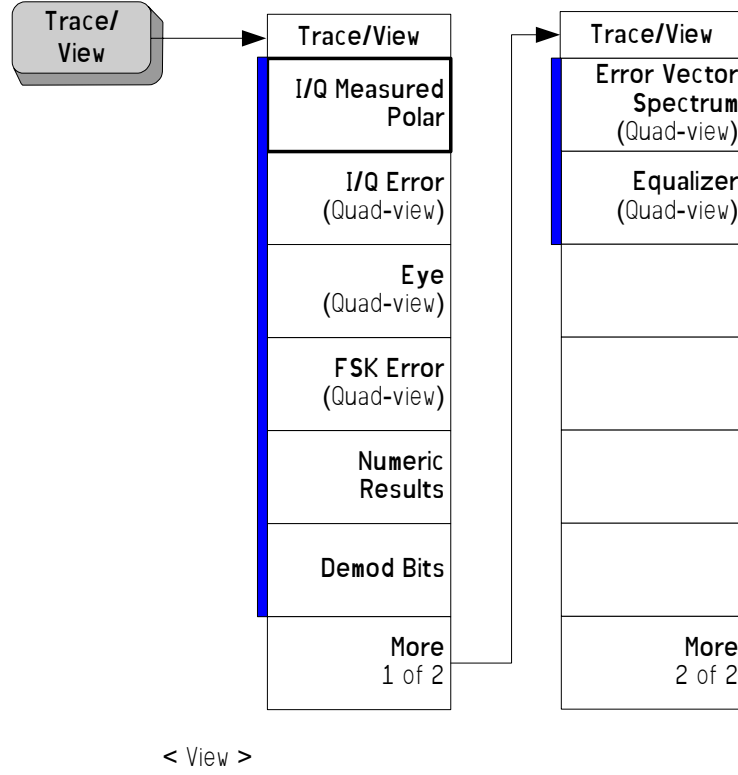
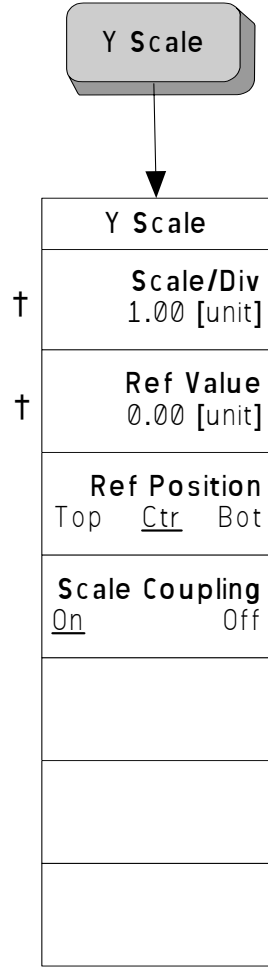

Figure 5-15 X Scale/ Y Scale Selection Key Flow



Numerics

128QAM, 87
16QAM, 87
256QAM, 87
2FSK, 91
2FSK example, 91
32QAM, 87
3rd generation RF cellular
 W-CDMA, 242
4FSK, 91
64QAM, 87
64QAM example, 87
 eye diagram (quad-view), 88
 I/Q error (quad-view), 88
 I/Q measured polar graph, 87
8 steps to make a modulation
 measurement, 48
8FSK, 91
8PSK, 85

A

active license key, 23
 how to locate, 23
adaptive equalization, setting, 56
ADC Range key, 169
Advanced key, 166
advanced measurement settings,
 59
alpha/BT, setting, 53
AMPLITUDE Y Scale key, 141
APCO-25 characteristics, 271
APCO25 Phase1 key, 132
application information, 2
ARFCN
 explained, 268
AutoTrig key, 138

B

band data
 GSM, 267
base transceiver stations, 268
baseband filtering errors, 113
bit state diagrams, 224
Bluetooth, 91
Bluetooth example, 91, 92
 FSK error (quad-view), 92
 I/Q measured polar graph, 91
Bluetooth key, 132
BPSK, 85
broadband interference, 242
burst search threshold, setting,
 55
Burst/Sync key, 159
burst/sync search, setting, 55

C

carrier frequency, 263
Carrier Lock key, 165
cdma2000 example, 85
 eye diagram (quad-view), 86
 I/Q error (quad-view), 86
 I/Q measured polar graph, 85
cdma2000 key, 131
cdmaOne key, 131
Center Frequency key, 124
CF Step key, 125
Choose Option key, 22
Clock Adjust key, 168
clock adjust, setting, 59
compression, 117
correlative code, 242
Cross key, 150

D

D8PSK, 85
Delay key
 External Trigger, 136
 RF Burst trigger, 134
 Video (IF Envelope) Trigger, 135
deleting an
 application/personality, 18
Demod key, 133, 153
demodulation parameters, setting,
 53
Det/Demod key, 124
Device key, 132
Diamond key, 150
Differential Modulation
 TETRA, 209
digital communications technique
 direct sequence
 spread-spectrum, 242
Digital Modulation, 191
display
 numeric results table, 66
Display key, 144
DQPSK, 85
DVB-C QAM bit state diagrams,
 234

E

EDGE, 89
EDGE example, 89
 eye diagram (quad-view), 90
 I/Q error (quad-view), 90
 I/Q measured polar graph, 89
Equalization front-panel key, 163
equalization, setting
 convergence, 56
 equalizer hold, 58
 filter length, 56

 filter on/off, 56
 resetting the filter, 58
equalizer (quad view), 58, 307
equipment setup diagram
 base station measurement
 station, 29
 mobile station measurement
 station, 28
error code
 16, input overload, 119
 601, signal too noisy, 119
 604, can not correlate to input
 signal, 120
 measurement instability, low
 input signal level, 119
EVM limits, setting, 59
EVM versus symbol graph, 73
EVM vs time
 filter alpha comparison
 example, 114
 symbol rate error example, 116
EVM vs time display, viewing, 73
example
 burst/sync, setting, 56
 constellation, AM interference,
 109
 constellation, I/Q DC offset
 error, 106
 constellation, I/Q quadrature
 error, 105
 constellation, PM interference,
 107
 EVM vs time filter alpha
 comparison, 114
 EVM vs time symbol rate error,
 116
 eye diagram, I/Q gain
 imbalance, 104
 I/Q constellation filter alpha
 comparison, 113
 I/Q constellation showing
 compression, 117
 I/Q constellation showing
 spurious interference, 112
 I/Q constellation symbol rate
 comparison, 115
 I/Q polar constellation display,
 I/Q gain imbalance, 103
 magnitude error graph, PM
 interference, 110
 measurement setup form, 52
 modulation analysis, setting up,
 63
 phase error graph, PM
 interference, 108
 spectrum display showing
 spurious interference, 111

- Ext Front key
 - external trigger source, 136
- Ext Rear key
 - external trigger source, 137
- external attenuator
 - BTS tests, 128
 - MS tests, 128
- eye diagram (quad-view), 75
 - 64QAM example, 88
 - cdma2000 example, 86
 - EDGE example, 90
 - PSK example, 86
- eye diagram, viewing, 75
- eye I diagram, 76

- F**
- factory preset, 30
- filtering errors, 113
- firmware upgrade information, 2
- form, measurement setup, 52
- Frame Timer key, 138
- FREQUENCY Channel key, 124
- frequency error limits, setting, 59
- Front-Panel key
 - Det/Demod, 124
 - Display, 144
 - FREQUENCY-Channel, 124
 - Input/Output, 126
 - Marker, 148
 - Meas Control, 129
 - Meas Setup, 150
 - MEASURE, 130
 - Mode, 130
 - Mode Setup, 131
 - Trace/View, 179
 - Trig, 133
 - X Scale, 176
- FSK, 91
- FSK bit state diagrams, 224
- FSK error (quad-view), 78
 - Bluetooth example, 92
- FSK error (quad-view), viewing, 77
- FSK error spectrum, 81
- FSK error spectrum, viewing, 81
- FSK error vs symbol, 79
- FSK error vs time, viewing, 79
- FSK measured time graph, 83
- FSK measured time, viewing, 83
- Full Vector key, 145

- G**
- gain imbalance, 103
- graph
 - EVM versus symbol, 73
 - eye diagram (quad-view), 75
 - eye I diagram, 76
- FSK error (quad-view), 78
- FSK error spectrum, 81
- FSK error vs symbol, 79
- FSK measured time, 83
- magnitude error versus symbol, 68
- phase error versus symbol, 70
- GSM band data, 267
- GSM example, 93, 94
 - I/Q error (quad-view), 94
 - I/Q measured polar graph, 93
- GSM key, 132
- GSM standards, 266

- H**
- higher level security, 242
- hopping, 264

- I**
- I/Q constellation
 - AM interference example, 109
 - DC offset error example, 106
 - filter alpha comparison example, 113
 - PM interference example, 107
 - quadrature error example, 105
 - signal compression example, 117
 - spurious signal interference example, 112
 - symbol rate comparison example, 115
- I/Q DC offset error, 106
- I/Q error (quad-view)
 - 64QAM example, 88
 - cdma2000 example, 86
 - EDGE example, 90
 - GSM example, 94
 - MSK example, 94
 - PSK example, 86
- I/Q error (quad-view) display, viewing, 67
- I/Q gain imbalance, 103
- I/Q measured polar graph
 - 64QAM example, 87
 - Bluetooth example, 91
 - cdma2000 example, 85
 - EDGE example, 89
 - FSK example, 91
 - GSM example, 93
 - MSK example, 93
- I/Q Points key, 144
- I/Q Points Offset key, 145
- I/Q polar constellation
 - I/Q gain imbalance example, 103
- I/Q polar constellation display, viewing, 64
- I/Q Polar Type key, 146
- I/Q polar vector and constellation graph, viewing, 64
- I/Q quadrature (skew) error, 105
- I/Q Rotation key, 147
- IEEE 802.15.4
 - Zigbee, 277
- IF Band Width key, 166
- impairment
 - eye diagram, I/Q gain imbalance example, 104
- impairments
 - filtering errors, 113
 - I/Q dc offset error, 106
 - I/Q gain imbalance, 103
 - I/Q quadrature (skew) error, 105
 - In-channel AM interference, 109
 - In-channel PM interference, 107
 - In-channel spurious interference, 111
 - signal compression, 117
 - symbol rate errors, 115
 - In-channel amplitude modulation interference, 109
 - In-channel phase modulation interference, 107
 - In-channel spurious signal interference, 111
- increased capacity
 - frequency reuse, 242
 - sectorized cells, 242
- information, additional, 2
- initial signal connection, 28
- input
 - external RF attenuator, 127
 - input attenuator, 127
- Input key, 133
- input port
 - 50 MHz reference, 126
 - IF align, 126
 - RF, 126
- Input/Output key, 126
- Install Now key, 22
- Installing and Obtaining a license key, 22
- installing measurement personalities, 18
- interpreting measurement results (impairments), 102
- inverting the spectrum, 59

- L**
- Level key

- External Trigger, 137
- Video (IF Envelope) trigger, 135
- license key
 - obtaining and installing, 22
- Limits key, 166
- Line key, 150
- list of
 - supported basic modulation formats, 62
- loading an
 - application/personality, 18
- M**
- magnitude error graph
 - PM interference example, 110
- magnitude error versus symbol graph, 68
- magnitude error vs time display, viewing, 68
- major functional keys, 122
- making EDGE measurements, 89
- making FSK measurements, 91
- making measurements, chapter introduction, 25
- making measurements,
 - equipment setup, 28
- making modulation analysis
 - measurements, 8 steps, 48
- making MSK measurements, 93
- making PSK measurements, 85
- making QAM measurements, 87
- Marker All Off key, 150
- Marker key, 148
- markers
 - band power key, 149
 - delta key, 149
 - function key, 149
 - noise key, 149
 - normal key, 149
 - off key, 149
- Meas Control key, 129
- meas setup
 - meas filter, 155
 - CDMA (IS-95 Base) EQ, 155
 - EMF (EDGE), 155
 - Gaussian, 155
 - Half Sine, 155
 - Nyquist, 155
 - Rectangle, 155
 - Root Nyquist, 155
- Meas Setup key, 150
- MEASURE key, 130
- measurement control measure, 129
 - continuous, 129
 - single, 129
- pause, 130
 - resume, 130
 - restart, 129
- measurement filter, setting, 53
- measurement final checks, 50
- measurement problems
 - can not correlate to input signal, 120
 - input overload, 119
 - low input signal level, 119
 - signal too noisy, 119
- measurement procedure
 - EDGE format, 89
 - FSK formats, 91
 - MSK formats, 93
 - PSK formats, 85
 - QAM formats, 87
 - setting up the personality, 63
- measurement results
 - interpreting impairments, 102
- measurement setup form, 52
- measurement view
 - 64QAM example, 87
 - Bluetooth example, 91
 - cdma2000 example, 85
 - EDGE example, 89
 - EVM vs time, 73
 - eye diagram, 75
 - FSK error (quad-view), 77
 - FSK error spectrum, 81
 - FSK error vs time, 79
 - FSK measured time, 83
 - GSM example, 93
 - I/Q error (quad-view), 67
 - I/Q polar constellation, 64
 - I/Q polar vector graph, 64
 - magnitude error vs time, 68
 - numeric results table, 66
 - phase error vs time, 70
- measuring
 - FSK formats, 91
 - MSK formats, 93
 - PSK formats, 85
 - QAM formats, 87
- measuring in the frequency domain, 31
- measuring in the time domain, 41, 47
- measuring RF parameters, 31
- missing options, 18
- mobile stations, 268
- Mode key, 130
- mode preset, 30
- Mode Setup key, 131
- modifying measurement setup parameters, 52
- modulation, 263
- Modulation Analysis key, 130
- modulation format, setting, 53
- modulation formats, 62
 - 16QAM, 32QAM, 64QAM, 128QAM, 256QAM, 87
 - BPSK, QPSK, 8PSK, DQPSK, D8PSK, pi/4 DQPSK, offset QPSK, 85
 - EDGE, 89
 - FSK, 2FSK, 4FSK, 8FSK, 91
 - MSK, MSK type1, MSK type2, 93
 - MSK, 93
 - MSK example, 93
 - MSK type1, 93
 - MSK type2, 93
- N**
- NADC key, 131
- numeric results, 92, 94
 - Bluetooth example, 92
 - FSK example, 92
 - GSM example, 94
 - MSK example, 94
- numeric results table, display, 66
- numeric results table, viewing, 66
- O**
- Off key, 150
- Offset key, 139
- offset QPSK, 85
- operating range, 264
- options
 - loading/deleting, 18
- options not in instrument
 - memory, 18
- P**
- PDC key, 132
- Peak Level key
 - RF Burst Trigger, 134
- Period key, 139
- personality options not in instrument, 18
- phase error graph
 - PM interference example, 108
- phase error versus symbol graph, 70
- phase error vs time display, viewing, 70
- PHS key, 132
- pi/4 DQPSK, 85
- Points / Symbol key, 146
- preset, 30
 - user defined, saving, 30
- procedure

using the spectrum measurement, 31
using the waveform measurement, 41, 47
product information, 2
PSK, 85
PSK bit state diagrams, 226

Q

QAM, 87
QAM bit state diagrams, 230
QPSK, 85
quadrature (skew) error, 105

R

Radio key, 131
Radio Std key, 131
reference filter, setting, 53
Reset Offset Display key, 139
RF Burst key, 134

S

saving preset states, 30
search length, setting, 55
setting
 advanced measurement properties, 59
 alpha/BT, 53
 burst/sync, 55
 clock adjust, 59
 demodulation parameters, 53
 EVM limits, 59
 filters, 53
 frequency error limits, 59
 symbol rate, 53
 trigger source, 54
setting up measurement parameters, 52
Shape key, 150
signal compression, 117
Slope key
 External Trigger, 137
 RF Burst Trigger, 134
 Video (IF Envelope) trigger, 136
spectrum
 changing views, 35
 view/trace, 35
spectrum display
 spurious signal interference example, 111
Spectrum key, 130, 168
spectrum measurement, 31
 results, 34
Square key, 150
standards
 GSM, 266

supported basic modulation

 formats, 62
symbol rate errors, 115
symbol rate, setting, 53
sync
 RF amplitude, 55
 setting, 55
 sync word burst, 55
 sync word count, 55
Sync key, 159
Sync Offset key, 161
Sync Pattern key, 161
sync pattern, setting, 56
Sync Source key, 140
sync word length, setting, sync offset, setting, 56

T

test equipment, setup, 28
TETRA, 209
TETRA key, 132
timeslot
 explained, 269
Trace/View key, 179
trace/view selection
 magnitude & phase graph view, 44
transmit power, 264
transmitted bit rate
 chip rate, 242
 spread data rate, 242
Trig key, 133
Trigger Holdoff key, 138
Trigger key, 133
Trigger Setup key, 133
trigger source, setting, 54
trigger, setting
 ext front, 54
 ext rear, 54
 frame, 54
 free run (immediate), 54
 RF burst (wideband), 54
 video (IF envelope), 54
triggering setup help, waveform measurement, 41, 47

U

Uninstall Now, 23
uninstalling measurement personalities, 18
uplink and downlink, 268
URL, PSA analyzers, 2
user-defined preset, 30
using equalization, 56

V

variable data rates, 242
VDL Mode 3 characteristics, 276
VDL Mode3 key, 132
Video (IF Envp) key, 135
view/trace
 spectrum graph, 35
view/trace selection
 I/Q waveform graph window, 36
 I/Q Waveform view, 44
 Spectrum I/Q Waveform view, 35
viewing the time domain, 41, 47

W

waveform
 results, 43
Waveform key, 130
waveform measurement, 41, 47
 results, 43
W-CDMA
 3rd generation RF cellular, 242
 wideband code division multiple access, 242
W-CDMA key, 131
wideband code division multiple access
 W-CDMA, 242

X

X Scale key, 176

Y

Y Ref Position key, 143
Y Ref Value key, 143
Y Scale / Div key, 142
Y Scale Coupling key, 144

Z

ZigBee 2450MHz key, 132
Zigbee characteristics, 277